

# REC POWER DEVELOPMENT AND CONSULTANCY LIMITED

(A wholly owned subsidiary of REC Ltd.)

## GLOBAL INVITATION (Through e-bidding Only)

FOR SELECTION OF TRANSMISSION SERVICE PROVIDER THROUGH TARIFF BASED COMPETITIVE BIDDING (TBCB) PROCESS ON BUILD, OWN, OPERATE AND TRANSFER (BOOT) BASIS FOR 01 (ONE) INTER – STATE TRANSMISSION PROJECT

REC Power Development and Consultancy Limited, New Delhi, India (a wholly owned subsidiary of REC Limited, a Maharatna Central Public Sector Undertaking) invites proposal for setting up of the below mentioned transmission project through TBCB process on Build, Own, Operate and Transfer (BOOT) basis following single stage two envelope process of "Request for Proposal (RFP)". Interested bidders may refer to the Request for Proposal (RFP) notifications and RFP documents available on our websites [www.recpdcl.in](http://www.recpdcl.in) & [www.recindia.nic.in](http://www.recindia.nic.in) w.e.f. 25.03.2026.

The bidders may obtain the RFP documents on all working days between 10:30 hours (IST) to 16:00 hours (IST) from 25.03.2026 to one day prior to bid submission date on payment of non-refundable fee of Rs. 5,00,000/- (Rupees Five Lakh Only) or US\$ 7000 (US Dollars Seven Thousand Only) + 18% GST as per details provided in the RFP document available on the websites [www.recpdcl.in](http://www.recpdcl.in) & [www.recindia.nic.in](http://www.recindia.nic.in).

The Request for Proposal (RFP) documents can also be downloaded from our websites [www.recpdcl.in](http://www.recpdcl.in) & [www.recindia.nic.in](http://www.recindia.nic.in), however, in such cases interested parties can submit Response to RFP only on submission of non-refundable fee of Rs. 5,00,000/- (Rupees Five Lakh Only) or US\$ 7000 (US Dollars Seven Thousand Only) + 18% GST as per details provided in the RFP document. The clarifications to RFP document shall be issued to those bidders, who have obtained/purchased RFP documents by paying requisite fee. The important timelines in this regard are as follows:

Sr. No.	Name of Project	Last Date for seeking clarifications	Last Date for submission of Response to RFP	Details of Opening of Response to RFP
1.	Augmentation at Bhadla-III, Ramgarh PS and Kanpur (PG)	14.04.2026	28.05.2026 up to 1500 Hrs (IST)	28.05.2026 at 1530 Hrs (IST)

All corrigenda, addenda, amendments, time extensions, etc. to the RFP will be hosted on our websites [www.recpdcl.in](http://www.recpdcl.in) & [www.recindia.nic.in](http://www.recindia.nic.in). Bidders should regularly visit our websites to keep themselves updated.

Note: RECPDCL reserves the right to cancel or modify the process without assigning any reason and without any liability. This is not an offer.

Chief Executive Officer

REC Power Development and Consultancy Ltd.

Core-4, SCOPE Complex, 7, Lodhi Road, New Delhi-110003, India

Bid Process Coordinator

An Initiative of

Initiative Partner



REC Power Development and Consultancy Limited

Ministry of Power Government of India

Central Electricity Authority

ऊर्जा ही जीवन है, इसे बचाएं।

Give a missed call on toll free number 18002003004 to get our Apps

# आरईसी पावर डेवलपमेंट एंड कंसल्टेंसी लिमिटेड

(आरईसी लिमिटेड के पूर्ण स्वामित्व की सहायक कंपनी)

वैश्विक आमंत्रण (इलेक्ट्रॉनिक बोली के माध्यम से)

टैरिफ के जरिए प्रतियोगिता बोली (टीबीसीबी) प्रक्रिया के माध्यम से 01 (एक) अंतर-राज्यीय पारेषण परियोजना के निर्माण, स्वामित्व, प्रचालन और हस्तांतरण (बीओओटी) आधारित पारेषण सेवा प्रदाता के चयन के लिए

आरईसी पावर डेवलपमेंट एंड कंसल्टेंसी लिमिटेड, नई दिल्ली, भारत (आरईसी लिमिटेड के पूर्ण स्वामित्व की सहायक कंपनी - एक महाराष्ट्र केंद्रीय सार्वजनिक उपक्रम) नीचे उल्लिखित पारेषण परियोजना की स्थापना हेतु टी.बी.सी.बी. के अंतर्गत निर्माण, स्वामित्व, प्रचालन और हस्तांतरण (बूट) के आधार पर प्रस्ताव हेतु अनुरोध (आरएफपी) एक चरण दो लिफाफे वाली प्रक्रिया के तहत प्रस्ताव आमंत्रित करता है। इच्छुक बोलीदाता कृपया हमारी वेबसाइट्स [www.recindia.nic.in](http://www.recindia.nic.in) तथा [www.recpdcl.in](http://www.recpdcl.in) पर 25.03.2026 से उपलब्ध "प्रस्ताव हेतु अनुरोध" (आरएफपी) अधिसूचना तथा आरएफपी दस्तावेज का अवलोकन करें।

बोलीदाता, आरएफपी दस्तावेज सभी कार्य दिवसों में 10:30 बजे (भा.मा.स) से 16:00 बजे (भा.मा.स) के बीच (25.03.2026 से प्रस्ताव जमा करने की तिथि से एक दिन पहले तक) हमारी वेबसाइट्स [www.recindia.nic.in](http://www.recindia.nic.in) और [www.recpdcl.in](http://www.recpdcl.in) पर उपलब्ध परियोजना के आरएफपी दस्तावेज में दिए गए विवरण के अनुसार अप्रतिदेय गैर-वापसी योग्य शुल्क (₹5,00,000/- (पांच लाख रुपए केवल) या \$7000 (यूएस डालर सात हजार केवल) + 18% जीएसटी) के भुगतान पर प्राप्त कर सकते हैं।

आरएफपी दस्तावेज हमारी वेबसाइट्स [www.recindia.nic.in](http://www.recindia.nic.in) तथा [www.recpdcl.in](http://www.recpdcl.in) से भी डाउनलोड किया जा सकता है। तथापि, ऐसे मामले में इच्छुक पार्टी आरएफपी दस्तावेज में दिए गए विवरण के अनुसार अप्रतिदेय गैर-वापसी योग्य शुल्क (₹5,00,000/- (पांच लाख रुपए केवल) या \$7000 (यूएस डालर सात हजार केवल) + 18% जीएसटी) का अलग से भुगतान करने पर ही आरएफपी के उत्तर में प्रस्ताव जमा कर सकते हैं। आरएफपी दस्तावेजों के स्पष्टीकरण उन्हीं बोलीदाताओं को जारी किया जाएगा, जिन्होंने अपेक्षित शुल्क का भुगतान करके आरएफपी दस्तावेज प्राप्त किया या खरीदा है। इस सन्दर्भ में महत्वपूर्ण समय-सीमा इस प्रकार है:

क्रम. सं.	परियोजना का नाम	स्पष्टीकरण मंगवाने की अंतिम तिथि	आरएफपी के उत्तर में प्रस्ताव जमा की अंतिम तिथि	आरएफपी प्रस्ताव खोलने का विवरण
1.	भड़ला-III, रामगढ़ पीएस और कानपुर में संवर्धन (पीजी)	14.04.2026	28.05.2026, 1500 बजे तक (भा.मा.स)	28.05.2026 को 1530 बजे (भा.मा.स)

बोली में सभी शुद्धिपत्र, अनुशेष, संशोधन, समय बढ़ाना आदि हमारी वेबसाइट्स [www.recindia.nic.in](http://www.recindia.nic.in) तथा [www.recpdcl.in](http://www.recpdcl.in) पर होस्ट किए जाएंगे। नवीनतम जानकारी के लिए हमारी वेबसाइट का नियमित रूप से अवलोकन करते रहे।

नोट: आरईसीपीडीसीएल के पास बिना कोई कारण बताए तथा बिना किसी बाध्यता के बोली प्रक्रिया को रद्द या संशोधित करने का अधिकार सुरक्षित है। यह कोई पेशकश नहीं है।

मुख्य कार्यपालक अधिकारी

आरईसी पावर डेवलपमेंट एंड कंसल्टेंसी लिमिटेड

कोर - 4, स्कोप कॉम्प्लेक्स, लोधी रोड, नई दिल्ली - 110003, भारत

बोली प्रक्रिया समन्वयक



पहलकर्ता



पहलकर्ता भागीदार



आरईसी पावर डेवलपमेंट एंड कंसल्टेंसी लिमिटेड

विद्युत मंत्रालय  
भारत सरकार

केंद्रीय विद्युत प्राधिकरण

ऊर्जा ही जीवन है, इसे बचाएं।

Give a missed call on toll free number 18002003004 to get our Apps

**SINGLE STAGE REQUEST FOR PROPOSAL DOCUMENT**

**FOR**

**SELECTION OF BIDDER AS TRANSMISSION SERVICE  
PROVIDER THROUGH TARIFF BASED COMPETITIVE  
BIDDING PROCESS**

**TO**

**ESTABLISH INTER-STATE TRANSMISSION SYSTEM**

**FOR**

**AUGMENTATION AT BHADLA-III, RAMGARH PS AND  
KANPUR (PG)**

**ISSUED BY**

**REC Power Development and Consultancy Limited  
(A wholly owned subsidiary of REC Limited)**

**Registered Office:  
Core-4, SCOPE Complex,  
7, Lodhi Road, New Delhi – 110 003  
Email: vijay.kulkarni@recpdcl.in & tbc@recpdcl.in**

**25.03.2026**

**REC Power Development and Consultancy Limited**  
**(A wholly owned subsidiary of REC Limited)**  
**Core-4, SCOPE Complex,**  
**7, Lodhi Road, New Delhi – 110 003**

**Request for Proposal Document for selection of Bidder as Transmission Service Provider through tariff based competitive bidding process to establish Inter-State Transmission system for “Augmentation at Bhadla-III, Ramgarh PS and Kanpur (PG)” is issued by REC Power Development and Consultancy Limited.**

This RFP document is issued to -

M/s. \_\_\_\_\_  
\_\_\_\_\_  
\_\_\_\_\_  
\_\_\_\_\_  
\_\_\_\_\_

**Chief Executive Officer,**  
**REC Power Development and Consultancy Limited**  
**(A wholly owned subsidiary of REC Limited)**

Email: .....

Place: .....

Date: .....

Signature: .....

**REQUEST FOR PROPOSAL NOTIFICATION**

**REC Power Development and Consultancy Limited**  
**(A wholly owned subsidiary of REC Limited)**  
**Core-4, SCOPE Complex,**  
**7, Lodhi Road, New Delhi – 110 003**

1. The Ministry of Power, Government of India, vide its Gazette Notification no. CG-DL-E-19022026-270309 dated 12.02.2026 has notified REC Power Development and Consultancy Limited (RECPDCL) to be the Bid Process Coordinator (BPC) for the purpose of selection of Bidder as Transmission Service Provider (TSP) to establish Inter-State transmission system for **“Augmentation at Bhadla-III, Ramgarh PS and Kanpur (PG)”** through tariff based competitive bidding process.
2. REC Power Development and Consultancy Limited (hereinafter referred to as BPC) hereby invites all prospective Bidders for issue of Request for Proposal (RFP) for selection of Bidder as Transmission Service Provider (TSP) on the basis of international competitive bidding in accordance with the “Tariff Based Competitive Bidding Guidelines for Transmission Service” and “Guidelines for Encouraging Competition in Development of Transmission Projects” issued by Government of India, Ministry of Power under section – 63 of The Electricity Act, 2003 and as amended from time to time. The responsibility of the TSP would be to establish the following Inter-State Transmission System - **“Augmentation at Bhadla-III, Ramgarh PS and Kanpur (PG)”** (hereinafter referred to as 'Project') on Build, Own, Operate & Transfer basis and to provide transmission service:

Sl. No.	Scope of the Transmission Scheme	Scheduled COD in months from Effective Date
1.	Augmentation of 400/220 kV, 5x500 MVA (6 <sup>th</sup> to 10 <sup>th</sup> ) ICTs at 765/400/220 kV Bhadla-III PS <ul style="list-style-type: none"> <li>• 500 MVA, 400/220 kV ICT - 5 Nos. (4 Nos. ICTs in 220 kV Sec-2 (6<sup>th</sup> to 9<sup>th</sup>) and 1 No. ICT in 220 kV Sec-1 (10<sup>th</sup>))</li> <li>• 400 kV ICT bay – 5 Nos.</li> <li>• 220 kV ICT bay – 4 Nos.</li> <li>• 220 kV ICT (GIS) bay – 1 No. (for 10<sup>th</sup> ICT)</li> <li>• 220 kV GIS bus duct/Cable for interconnection of 220 kV side of ICT (10<sup>th</sup>) to 220 kV GIS bay (Section-1)</li> </ul>	20.01.2029 (matching with timeframe of Transmission System for Evacuation of Power from REZ in Rajasthan (20 GW) under Phase III – Part I scheme (Pole 1))
2.	Implementation of 5 Nos. of 220 kV line bays at 765/400/220 kV Bhadla-III PS. <ul style="list-style-type: none"> <li>• 220 kV line bay – 5 Nos.</li> </ul>	
3.	Implementation of 1 No. of 400 kV line bay at 765/400/220 kV Bhadla-III PS. <ul style="list-style-type: none"> <li>• 400 kV line bay – 1 No.</li> </ul>	
4.	Implementation of 2 sets 400 kV sectionlizer bay at 765/400/220 kV Bhadla-III PS	

Sl. No.	Scope of the Transmission Scheme	Scheduled COD in months from Effective Date
	<ul style="list-style-type: none"> <li>400 kV sectionlizer bay – 2 sets</li> </ul>	
5.	Augmentation of 765/400 kV, 2x1500 MVA (3 <sup>rd</sup> & 4 <sup>th</sup> ) ICTs at 765/400/220 kV Ramgarh PS <ul style="list-style-type: none"> <li>1500 MVA, 765/400 kV ICT - 2 Nos.</li> <li>765 kV ICT bay – 2 Nos.</li> <li>400 kV ICT bay – 2 Nos.</li> </ul>	
6.	Augmentation of 400/220 kV, 2x500 MVA (3 <sup>rd</sup> & 4 <sup>th</sup> ) ICTs at 765/400/220 kV Ramgarh PS <ul style="list-style-type: none"> <li>500 MVA, 400/220 kV ICT - 2 Nos.</li> <li>400 kV ICT bays – 2 Nos.</li> <li>220 kV ICT bay – 2 Nos.</li> </ul>	
7.	Implementation of 2 Nos. of 220 kV line bays at 765/400/220 kV Ramgarh PS <ul style="list-style-type: none"> <li>220 kV line bay – 2 Nos.</li> </ul>	
8.	Implementation of 1 No. of 400 kV line bay at 765/400/220 kV Ramgarh PS <ul style="list-style-type: none"> <li>400 kV line bay – 1 No.</li> </ul>	
9.	Augmentation of 765/400 kV, 1x1500 MVA (3 <sup>rd</sup> ) ICT at 765/400 kV Kanpur (PG) substation <ul style="list-style-type: none"> <li>1500 MVA (3x500 MVA), 765/400 kV ICT - 1 No.</li> <li>765 kV ICT bay (GIS) including completion of diameter.</li> <li>400 kV ICT bay (GIS) in existing spare bay</li> <li>All associated GIS duct with terminations.</li> </ul>	

- The TSP shall ensure that design, construction and testing of all equipment, facilities, components and systems of the Project shall be in accordance with the provisions of the Transmission Service Agreement and applicable Rules/ Regulations, Orders and Guidelines issued by the Central Government.
- Transmission License:** The TSP shall obtain the Transmission License from the Commission.
- Bidding Process:** The Transmission Service Provider shall be selected through tariff based competitive bidding process for the Project based on meeting stipulated Qualification Requirements prescribed in Clause 2.1 of Section 2 of RFP and the lowest Quoted Transmission Charges discovered from Final Offers quoted during the e-reverse bidding. The selection of the TSP shall be subject to it obtaining Transmission License from the Commission, which, after expiry, may be further extended by such period as deemed appropriate by the Commission under powers vested with it to amend the conditions of the Transmission License.

The entire bidding process shall be conducted on electronic platform created by MSTC Limited.

The Bid shall be a single stage two envelope bid comprising the Technical Bid and the Financial Bid. The Bidders shall submit the Bid online through the electronic bidding platform. In addition to the online submission, the Bidder with lowest Final Offer will be required to submit original hard copies of Annexure 3, Annexure 4 (if applicable), Annexure 6 (if applicable) and Annexure 14/14A/14B before issuance of LoI. There shall be no physical submission of the Financial Bid.

The Technical Bid shall be opened first and the Financial Bid of only the bidders who have qualified in the Technical Bid shall be opened. The Financial Bid will comprise of two rounds. In the first round the Initial Offer of the responsive bids would be opened and Quoted Transmission Charges of Initial Offer shall be ranked on the basis of ascending order. The Bidders, in the first fifty per cent of the ranking (with any fraction rounded off to higher integer) or four Bidders, whichever is higher, shall qualify for participating in the electronic reverse auction stage and submit their Final Offer.

6. The objective of the bidding process is to select a Successful Bidder pursuant to this RFP, who shall acquire one hundred percent (100%) of the equity shares of ..... (Insert the name of SPV) along with all its related assets and liabilities as per the provisions of the Share Purchase Agreement, at the Acquisition Price to be intimated by the BPC, twenty (20) days prior to the Bid Deadline.

The ..... (Insert the name of SPV) of which one hundred percent (100%) equity shares will be acquired by the Selected Bidder, shall be responsible as the TSP, for ensuring that it undertakes ownership, financing, development, design, engineering, procurement, construction, commissioning, operation and maintenance of the Project, and to provide Transmission Service as per the terms of the RFP Project Documents.

The TSP shall ensure transfer of all project assets along with substation land, right of way and clearances to CTU or its successors or an agency as decided by the Central Government after 35 years from COD of project at zero cost and free from any encumbrance and liability. The transfer shall be completed within 90 days after 35 years from COD of project failing which CTU shall be entitled to take over the project assets Suo moto.

7. **Commencement of Transmission Service:** The Bidder shall have to commence Transmission Service in accordance with the provisions of the Transmission Service Agreement.
8. **Transmission Charges:** The Transmission Charges shall be payable by the Designated ISTS Customers in Indian Rupees through the CTU as per Central Electricity Regulatory Commission (Sharing of Inter-State Transmission Charges and Losses) Regulations as amended from time to time. Bidders shall quote the Transmission Charges as per the pre-specified structure, as mentioned in the RFP.
9. **Issue of RFP document:** The detailed terms and conditions for qualification and selection of the Transmission Service Provider for the Project and for submission of Bid are indicated in the RFP document. All those interested in purchasing the RFP document may respond in writing to Chief Executive Officer, vijay.kulkarni@recpdcl.in & tbc@recpdcl.in at the address given in para 12 below with a non-refundable fee of Rs. 5,00,000/- (Rupees Five

Lakh Only) or US\$ 7,000 (US Dollars Seven Thousand Only) plus GST @18%, to be paid latest by 26.05.2026 via electronic transfer to the following Bank Account:

Bank Name, Address & Branch	ICICI Bank 9A, Phelps Building, Inner Circle, Connaught Place, New Delhi-110001
Bank Account Name	REC Power Development & Consultancy Limited
Bank Account No	000705041275
Bank IFSC Code No	ICIC0000007

Immediately after issuance of RFP document, the Bidder shall submit the Pre-Award Integrity Pact in the format as prescribed in Annexure B, which shall be applicable for and during the bidding process, duly signed on each page by any whole-time Director / Authorized Signatory, duly witnessed by two persons, and shall be submitted by the Bidder in two (2) originals in a separate envelope, duly superscripted with Pre-Award Integrity Pact. The Bidder shall submit the Pre-Award Integrity Pact on non-judicial stamp paper of Rs. 100/- each duly purchased from the National Capital Territory of Delhi. In case the Bidder is in a consortium, the Pre-Award Integrity Pact shall be signed and submitted by each member of the Consortium separately.

The RFP document shall be issued to the Bidders on any working day from 25.03.2026 to 26.05.2026 between 1030 hours (IST) to 1600 hours (IST). The BPC, on written request and against payment of the above mentioned fee by any Bidder shall promptly dispatch the RFP document to such Bidder by registered mail/ air mail. BPC shall, under no circumstances, be held responsible for late delivery or loss of documents so mailed.

10. **Receipt and opening of Bid:** The Bid must be uploaded online through the electronic bidding platform on or before 1500 hours (IST) on 28.05.2026. Technical Bid will be opened by the Bid Opening Committee on the same day at 1530 hours (IST) in the office of Central Electricity Authority, in the online presence of Bidders’ representatives who wish to attend. If the Bid Deadline is a public holiday at the place of submission of Bid, it shall be opened on the next working day at the same time and venue. In addition to the online submission, the Bidder with lowest Final Offer will be required to submit original hard copies of Annexure 3, Annexure 4 (if applicable), Annexure 6 (if applicable) and Annexure 14/14A/14B before issuance of LoI. Bidders meeting the Qualification Requirements, subject to evaluation as specified in Clause 3.2 to 3.4 shall be declared as “Qualified Bidders” and eligible for opening of Initial Offer.
11. The RFP document is not transferable. BPC reserves the right to reject all Bids and/or annul the process of tariff based competitive bidding for selection of Bidder as TSP to execute the Project without assigning any reason. BPC shall not bear any liability, whatsoever, in this regard.
12. **Nodal person for enquiries and clarifications**

All correspondence and clarification in respect of RFP document shall be addressed to:

Chief Executive Officer,  
REC Power Development and Consultancy Limited  
(A wholly owned subsidiary of REC Limited)  
REC Corporate Head Quarter,

D Block, Plot No. I – 4,  
Sec – 29 Gurugram – 122 001  
Email: vijay.kulkarni@recpdcl.in & tcb@recpdcl.in

**DISCLAIMER**

1. This Request for Proposal (RFP) document is not an agreement or offer by the BPC to the prospective Bidders or to any other party. The purpose of this RFP document is to provide interested parties with information to assist the formulation of their Bid. The RFP document is based on material and information available in public domain.
2. This RFP, along with its Annexure, is not transferable and the information contained therein are to be used only by the person to whom it is issued. It may not be copied or distributed by the recipient to third parties (other than in confidence to the recipient's professional advisors). In the event that the recipient does not continue with its involvement in the Project in accordance with this RFP, this RFP must be kept confidential.
3. While this RFP has been prepared in good faith, neither the BPC nor its employees or advisors/consultants make any representation or warranty expressed or implied as to the accuracy, reliability or completeness of the information contained in this RFP. The Bidders shall satisfy themselves, on receipt of the RFP document, that the RFP document is complete in all respects. Intimation of any discrepancy shall be given to this office immediately. If no intimation is received from any Bidder within ten (10) days from the date of issue of this RFP document on or before the date & time mentioned in this RFP, it shall be considered that the issued document, complete in all respects, has been received by the Bidders.

This bidding process is in accordance with the Bidding Guidelines issued by Ministry of Power, Government of India under Section 63 of the Electricity Act, 2003. Revisions or amendments in these Bidding Guidelines may cause the BPC to modify, amend or supplement this RFP document, including the RFP Project Documents to be in conformance with the Bidding Guidelines.

4. This RFP document includes statements, which reflect various assumptions arrived at by BPC in order to give a reflection of current status in the RFP. These assumptions should not be entirely relied upon by Bidders in making their own assessments. This RFP document does not purport to contain all the information each Bidder may require and may not be appropriate for all persons. It is not possible for BPC to consider the investment objectives, financial situation and particular needs of each party who reads or uses this RFP document. Certain Bidders may have a better knowledge of the Project than the others. Each Bidder should conduct its own investigations and analysis and should check the accuracy, reliability and completeness of the information in this RFP document and obtain independent advice from appropriate sources.
5. Neither BPC nor their employees or consultants make any representation or warranty as to the accuracy, reliability or completeness of the information in this RFP document.
6. Neither BPC, its employees nor its consultants will have any liability to any Bidder or any other person under the law of contract, tort, the principles of restitution or unjust enrichment or otherwise for any loss, expense or damage which may arise from or be incurred or suffered in connection with anything contained in this RFP document, any matter deemed to form part of this RFP document, the award of the Project, the information supplied by or on behalf of BPC or its employees, any consultants or otherwise arising in any way from the qualification process for the said Project.
7. By participating in the bidding process, each of the Bidder shall have acknowledged and

accepted that it has not been induced to enter into such agreement by any representation or warranty, expressed or implied, or relied upon any such representation or warranty by or on behalf of BPC or any person working in the bidding process.

8. BPC may in its absolute discretion, but without being under any obligation to do so, update, amend or supplement this RFP document. Such updations, amendments or supplements, if any, will however be circulated to the Bidders not later than 15 days prior to the last date for submission of Bid.
9. Each Bidder unconditionally agrees, understands and accepts that the BPC reserves the rights to accept or reject any or all Bids without giving any reason. Neither the BPC nor its advisers shall entertain any claim of any nature, whatsoever, including without limitations, any claim seeking expenses in relation to the preparation of Bids.
10. This RFP may be withdrawn or cancelled by the BPC at any time without assigning any reasons thereof. BPC further reserves the right, at its complete discretion to reject any or all of the Bids without assigning any reasons whatsoever.

## INDEX

<b>SECTION</b>	<b>CONTENTS</b>	<b>PAGE NO.</b>
	<b>Definitions</b>	<b>12</b>
<b>1.</b>	<b>Introduction</b>	<b>17</b>
<b>2.</b>	<b>Information And Instructions For Bidders</b>	<b>24</b>
<b>3.</b>	<b>Evaluation Of The Technical And Financial Bid</b>	<b>52</b>
<b>4.</b>	<b>Annexures For Bid</b>	<b>58</b>
	<b>Annexures</b>	
<b>1</b>	<b>Format for the Covering Letter</b>	<b>60</b>
<b>2</b>	<b>Format for Letter of Consent from Consortium Members</b>	<b>64</b>
<b>3</b>	<b>Format for evidence of authorized signatory's authority (Power of Attorney)</b>	<b>66</b>
<b>4</b>	<b>Format for Power of Attorney to be provided by each of the other members of the Consortium in favor of the Lead Member</b>	<b>68</b>
<b>5</b>	<b>Format for Bidder's composition and ownership structure and Format for Authorization</b>	<b>70&amp;72</b>
<b>6</b>	<b>Format for Consortium Agreement</b>	<b>73</b>
<b>7A</b>	<b>Format for Qualification Requirement – Net worth</b>	<b>78</b>
<b>7B</b>	<b>Format for Technical Requirement</b>	<b>81</b>
<b>7C</b>	<b>Format for Technical and Financial Requirement – Relationship &amp; Equity Shareholding</b>	<b>85</b>
<b>7D</b>	<b>Format for Additional Information for verification of Financial and Technical Capabilities of Bidders</b>	<b>87</b>
<b>8</b>	<b>Format for Undertaking and Details of Equity Investment</b>	<b>90</b>
<b>9</b>	<b>Format for Authorization from Parent / Affiliate of Bidding Company / Member of Bidding Consortium whose technical / financial capability has been used by the Bidding Company / Member of Bidding Consortium.</b>	<b>95</b>
<b>10</b>	<b>Format for Undertaking by Technically/Financially Evaluated Entity/Ultimate Parent Company</b>	<b>97</b>
<b>11</b>	<b>Format for Board Resolution</b>	<b>99</b>
<b>11A</b>	<b>Illustration for Applicable Board Resolution Requirements under Clause 2.5.2</b>	<b>102</b>
<b>12</b>	<b>Format for illustration of Affiliates</b>	<b>104</b>
<b>13</b>	<b>Format for disclosure</b>	<b>105</b>
<b>14</b>	<b>Format For Bid Bond</b>	<b>106</b>

<b>SECTION</b>	<b>CONTENTS</b>	<b>PAGE NO.</b>
<b>14 A</b>	<b>Format Of The Surety Bond For Bid Security</b>	<b>108</b>
<b>14B</b>	<b>Format of Payment on Order Instrument to be issued by IREDA/REC/PFC</b>	<b>110</b>
<b>15</b>	<b>Format for Contract Performance Guarantee</b>	<b>113</b>
<b>15A</b>	<b>Format For Surety Insurance Contract</b>	<b>115</b>
<b>15B</b>	<b>Format for Issuance of Payment on Order Instrument</b>	<b>118</b>
<b>16</b>	<b>Format for Checklist for Technical Bid Submission Requirements</b>	<b>121</b>
<b>17</b>	<b>List of Banks</b>	<b>124</b>
<b>18</b>	<b>Grid Map of the Project</b>	<b>125</b>
<b>19</b>	<b>Format for Clarifications / Amendments on the RFP / RFP Project Documents</b>	<b>127</b>
<b>20</b>	<b>Formats For RFP Project Documents</b>	<b>128</b>
<b>21</b>	<b>Format For Financial Bid</b>	<b>129</b>
<b>22</b>	<b>Format of Affidavit</b>	<b>130</b>
	<b>Annexure A</b>	<b>132</b>
	<b>Annexure-B</b>	<b>133</b>
	<b>Annexure-C</b>	<b>140</b>

## DEFINITIONS

Any capitalized term, used but not defined in this RFP, shall have the meaning ascribed to such term in the RFP Project Documents, or the Bidding Guidelines, in that order. In absence of availability of definitions in the foregoing references, the capitalized terms shall be interpreted in accordance with the Electricity Act 2003, Grid Code or any other relevant electricity law, rule or regulation prevalent in India, as amended or re-enacted from time to time, in that order.

### The following terms are defined for use in this RFP:

"**Acquisition Price**" shall have the same meaning as defined in the Share Purchase Agreement;

"**Affiliate**" shall mean a company that either directly or indirectly

- i. controls or
- ii. is controlled by or
- iii. is under common control with

a Bidding Company (in the case of a single company) or a Member (in the case of a Consortium) and "**control**" means ownership by one entity of at least twenty six percent (26%) of the voting rights of the entity. As an illustration a chart is annexed hereto as Annexure – 12;

"**Bid**" shall mean Technical Bid and Financial Bid (Initial Offer and Final Offer) submitted by the Bidder, in response to this RFP, in accordance with the terms and conditions thereof;

"**Bidder**" shall mean either a single company (including its permitted successors and legal assigns) or a Consortium of companies (including its permitted successors and legal assigns) submitting a Bid in response to this RFP. Any reference to the Bidder includes Bidding Company, Bidding Consortium/ Consortium, Member in a Bidding Consortium and Lead Member of the Bidding Consortium jointly and severally, as the context may require;

"**Bidding Company**" shall refer to such single company (including its permitted successors and legal assigns) that has submitted a Bid for the Project;

"**Bidding Consortium/ Consortium**" shall refer to a group of companies (including their permitted successors and legal assigns) that has collectively submitted a Bid for the Project;

"**Bidding Guidelines**" shall mean the "Tariff Based Competitive-Bidding Guidelines for Transmission Service" and "Guidelines for Encouraging Competition in Development of Transmission Projects" issued by Government of India, Ministry of Power under Section – 63 of Electricity Act as amended from time to time;

"**Bid Bond**" shall mean the unconditional and irrevocable Bank Guarantee or unconditional and irrevocable Insurance Surety Bond issued by Insurance Company authorized by Insurance Regulatory and Development Authority of India) or Payment on Order Instrument for **Rupees Seventeen Crores and Forty Lakhs (Rs. 17.40 Crore) Only**, to be submitted along with the Technical Bid by the Bidder under Clause 2.11 of this RFP, as per the format prescribed in Annexure 14 (for Bank Guarantee) or Annexure 14A (for Insurance Surety Bond) or Annexure 14B (for Payment on Order);

"**Bid Deadline**" shall mean the last date and time for submission of online Bid in response to this

RFP, specified in Clause 2.7.1;

**“Bid Process Coordinator or BPC”** shall mean a person or its authorized representative as notified by the Government of India, responsible for carrying out the process for selection of Bidder who will acquire Transmission Service Provider;

**"CEA"** shall mean the Central Electricity Authority constituted under Section - 70 of the Electricity Act;

**“Commission” or “CERC”** shall mean the Central Electricity Regulatory Commission of India constituted under Section-76 of The Electricity Act, 2003 and any successors and assigns;

**“Conflict of Interest”** A Bidder shall be considered to be in a Conflict of Interest with one or more Bidders in the same bidding process if they have a relationship with each other, directly or through a common company, that puts them in a position to have access to information about or influence the Bid of another Bidder.

Provided that if two or more bidders in the bidding process have formed a Joint Venture Company or Consortium to execute another project, the Bidders will not be considered to have Conflict of Interest;

**"Commercial Operation Date (COD)"** shall mean the date as per Article 6.2 of the Transmission Service Agreement;

**“Consents, Clearances, Permits”** shall mean all authorizations, licenses, approvals, registrations, permits, waivers, privileges, acknowledgements, agreements, or concessions required to be obtained from or provided by any concerned authority for the development, execution and performance of Project including without any limitation on the construction, ownership, operation and maintenance of the transmission lines and/or sub-stations;

**"Contract Performance Guarantee"** shall have the meaning as per Clause 2.12 of this RFP;

**"Contract Year"** shall mean the period beginning on the Scheduled COD, and ending on the immediately succeeding March 31 and thereafter each period of 12 months beginning on April 1 and ending on March 31 provided that:

- (i) the last Contract Year shall end on the last day of the term of the Transmission Service Agreement;

**"CTU/Central Transmission Utility"** shall have same meaning as defined in the Electricity Act, 2003;

**“Designated ISTS Customers”** or **“DICs”** shall have the meaning as ascribed in Regulation 2(l) of Central Electricity Regulatory Commission (Sharing of inter-State Transmission Charges and Losses) Regulation 2020 and as amended or modified from time to time;

**"Effective Date"** shall have the meaning as ascribed thereto in the Transmission Service Agreement;

**"Element"** shall mean-each Transmission Line or each circuit of the Transmission Lines (where there are more than one circuit) or each bay of the Sub-station or switching station or HVDC terminal

or inverter station of the Project, including ICTs, Reactors, SVC, FSC, etc. forming part of the ISTS which will be owned, operated and maintained by the concerned ISTS Licensee, and which may have a separate scheduled COD as per Schedule 2 of the Transmission Service Agreement and may have a separate percentage for recovery of Transmission Charges on achieving COD as per Schedule 5 of the Transmission Service Agreement;

**"National Committee on Transmission"** shall mean the committee constituted by the Ministry of Power, Government of India in terms of the "Guidelines for Encouraging Competition in Development of Transmission Projects", as notified from time to time;

**"Final Offer"** shall mean the Quoted Transmission Charges, required to be submitted as part of the Financial Bid on the electronic bidding platform during the e-reverse bidding stage. In case, no Final Offer is received during the e-reverse bidding stage then the lowest "Initial Offer" shall be deemed to be the Final Offer;

**"Financial Bid"** shall mean the Initial Offer and Final Offer, containing the Bidder's Quoted Transmission Charges, as per the format at Annexure – 21 of this RFP;

**"Financially Evaluated Entity"** shall mean the company which has been evaluated for the satisfaction of the financial requirement set forth in Clause 2.1.3 hereof;

**"Government"** shall mean the Central Government;

**"Grid Code" / "IEGC" or "State Grid Code"** shall mean the Grid Code specified by the Central Commission under clause (h) of sub-section (1) of Section 79 of the Electricity Act and/or the State Grid Code as specified by the concerned State Commission referred under clause (h) of sub-section (1) of Section 86 of the Electricity Act as applicable;

**"Infrastructure sector"** shall mean such sectors notified by Department of Economic Affairs in its Gazette Notification no. 13/1/2017-INF dated 14<sup>th</sup> November, 2017 and as amended from time to time;

**"Initial Offer"** shall mean the Quoted Transmission Charges, required to be submitted as part of the Financial Bid on the electronic bidding platform along with the Technical Bid;

**"Inter State Generating Station" or "ISGS"** shall mean a Central / other generating station in which two or more states have shares and whose scheduling is to be coordinated by the Regional Load Despatch Centre;

**"Inter-State Transmission System"** shall have same meaning as defined in the Electricity Act, 2003;

**"Lead Member of the Bidding Consortium" or "Lead Member"** shall mean a company who commits at least twenty six percent (26%) equity stake in the Project, meets the technical requirement as per Clause 2.1.2 and so designated by other Member(s) in Bidding Consortium;

**"Letter of Intent" or "LoI"** shall mean the letter to be issued by the BPC to the Bidder, who has been identified as the selected bidder, for award of the Project to such Bidder;

**"Member in a Bidding Consortium/Member"** shall mean each company in the Bidding Consortium;

“**MOP**” shall mean the Ministry of Power, Government of India;

"**MOEF**" shall mean the Ministry of the Environment and Forests, Government of India;

“**Nodal Agency**” shall mean CTU, which shall execute and implement the Transmission Service Agreement (TSA);

Provided that while taking major decisions, CTU shall consult CEA on technical matters and any other matter it feels necessary.

“**Parent Company**” shall mean an entity that holds at least twenty six percent (26%) of the paid - up equity capital directly or indirectly in the Bidding Company or in the Member in a Bidding Consortium, as the case may be;

“**Payment on Order Instrument**” shall mean Letter of Undertaking from Indian Renewable Energy Development Agency Limited (IREDA) or Power Finance Corporation Limited (PFC) or REC Limited (REC) [the three non banking financial institutions under Ministry of New & Renewable Energy (MNRE)/ Ministry of Power (MoP)], to pay in case situation of default of Transmission Service Provider (TSP) in terms of tender conditions/ Power Purchase Agreement (PPA) arises. Such Letter(s) will have same effect as that of a Bank Guarantee issued by any public sector bank. Such "Payment on Order instrument" would have terms and conditions similar to that of any Bank Guarantee given by any public sector bank and would promise to pay the Nodal Agency on demand within stipulated time. TSPs can seek such Letter(s) by offering due security to the above-mentioned three non-banking financial institutions mentioned above (IREDA, PFC & REC). Nodal Agency shall not accept the instrument of 'Letter of Undertaking' as described above or in any other form, from any other non-banking financial institutions or bank, except IREDA, PFC & REC.

“**Qualification Requirements**” shall mean the qualification requirements as set forth in Section-2, Clause 2.1 of this RFP;

“**Quoted Transmission Charges**” shall mean the quoted single annual Transmission Charges submitted online through the electronic bidding platform by the Bidder as part of its Financial Bid as per the format in Annexure – 21 of this RFP;

“**RFP**” shall mean Request for Proposal document along with all schedules, formats, annexure and RFP Project Documents attached hereto, issued by BPC for tariff based competitive bidding process for selection of bidder who will acquire the TSP through e-reverse bidding to execute the Project, and shall include any modifications, amendments or alterations or clarifications thereto;

“**RFP Project Documents**” shall mean the following documents to be entered into in respect of the Project, by the parties to the respective agreements:

- a. Transmission Service Agreement (TSA),
- b. Share Purchase Agreement,
- c. Agreement(s) required, if any, under Central Electricity Regulatory Commission (Sharing of Inter-State Transmission Charges and Losses) Regulations as amended from time to time and
- d. Any other agreement, as may be required;

"**Scheduled COD**" shall have the meaning as ascribed hereto in Clause 2.6 of this RFP;

**“Statutory Auditor”** shall mean the auditor appointed under the provisions of the Companies Act, 1956 / Companies Act, 2013 (as the case may be) or under the provisions of any other applicable governing law;

**"Share Purchase Agreement"** shall mean the agreement amongst REC Power Development and Consultancy Limited, ..... (Insert the name of SPV) and the Successful Bidder for the purchase of one hundred (100%) per cent of the shareholding of the ..... (Insert the name of SPV) for the Acquisition Price, by the Successful Bidder on the terms and conditions as contained therein;

**"Successful Bidder" or "Selected Bidder"** shall mean the Bidder selected pursuant to this RFP to acquire one hundred percent (100%) equity shares of ..... (Insert the name of SPV), along with all its related assets and liabilities, which will be responsible as the TSP to establish the Project on build, own, operate and transfer basis as per the terms of the Transmission Service Agreement and other RFP Project Documents;

**"Survey Report"** shall mean the report containing initial information regarding the Project and other details provided as per the provisions of Clause 1.6.2.1.1 of this RFP;

**"Technical Bid"** shall mean the bid submitted online through the electronic bidding platform, containing the documents as listed out in Clause 2.5.2 of this RFP;

**“Technically Evaluated Entity”** shall mean the company which has been evaluated for the satisfaction of the technical requirement set forth in Clause 2.1.2 hereof;

**“Transmission Charges”** shall mean the Final Offer quoted by Selected Bidder and adopted by the Commission, and as computed in terms of the provisions of Schedule 4 of the TSA, payable to the ISTS Licensee by the Designated ISTS Customers, and collected / disbursed by the CTU, as per Central Electricity Regulatory Commission (Sharing of Inter-State Transmission Charges and Losses) Regulations as amended from time to time;

**“Transmission License”** shall mean the license granted by the Commission in terms of the relevant regulations for grant of such license issued under the Electricity Act, 2003;

**“Transmission Service Agreement” or “TSA”** shall mean the agreement entered into between Nodal Agency and the TSP, pursuant to which the TSP shall build, own, operate and transfer the Project and make available the assets of the Project on a commercial basis;

**“Transmission Service Provider” or “TSP”** shall mean ..... (Insert the name of SPV) which has executed the Transmission Service Agreement and which shall be acquired by the Selected Bidder;

**“Ultimate Parent Company”** shall mean an entity which owns at least twenty six percent (26%) equity in the Bidding Company or Member of a Consortium, (as the case may be) and in the Technically Evaluated Entity and/or Financially Evaluated Entity (as the case may be) and such Bidding Company or Member of a Consortium, (as the case may be) and the Technically Evaluated Entity and/or Financially Evaluated Entity (as the case may be) shall be under the direct control or indirectly under the common control of such entity.

# **SECTION – 1**

# **INTRODUCTION**

## SECTION 1

## 1. INTRODUCTION

- 1.1 The Ministry of Power, Government of India, vide its Gazette Notification no. CG-DL-E-19022026-270309 dated 12.02.2026 has appointed REC Power Development and Consultancy Limited (RECPDCL) to be the Bid Process Coordinator (BPC) for the purpose of selection of Bidder as Transmission Service Provider (TSP) to establish Inter-State transmission system for **“Augmentation at Bhadla-III, Ramgarh PS and Kanpur (PG)”** through tariff based competitive bidding process.

The BPC hereby invites Bids from all prospective Bidders in accordance with this Request for Proposal (RFP) to select prospective Transmission Service Provider (TSP) in accordance with the “Tariff Based Competitive-Bidding Guidelines for Transmission Service” and “Guidelines for Encouraging Competition in Development of Transmission Projects” issued by Government of India, Ministry of Power under Section – 63 of the Electricity Act. The BPC shall select the Bidder having the prescribed technical and financial capability to become TSP and be responsible for establishing the Project in the state(s) of Rajasthan and Uttar Pradesh. The TSP will make the Project available against payment of Transmission Charges, as adopted by the Commission, payable to the TSP, as per Central Electricity Regulatory Commission (Sharing of Inter-State Transmission Charges and Losses) Regulations as amended from time to time.

- 1.2 The TSP will be required to establish the following Inter State Transmission System for **“Augmentation at Bhadla-III, Ramgarh PS and Kanpur (PG)”** (hereinafter referred to as ‘Project’) on build, own, operate and transfer basis, and to provide transmission service.

Sl. No.	Scope of the Transmission Scheme	Scheduled COD in months from Effective Date
1.	Augmentation of 400/220 kV, 5x500 MVA (6 <sup>th</sup> to 10 <sup>th</sup> ) ICTs at 765/400/220 kV Bhadla-III PS <ul style="list-style-type: none"> <li>• 500 MVA, 400/220 kV ICT - 5 Nos. (4 Nos. ICTs in 220 kV Sec-2 (6<sup>th</sup> to 9<sup>th</sup>) and 1 No. ICT in 220 kV Sec-1 (10<sup>th</sup>))</li> <li>• 400 kV ICT bay – 5 Nos.</li> <li>• 220 kV ICT bay – 4 Nos.</li> <li>• 220 kV ICT (GIS) bay – 1 No. (for 10<sup>th</sup> ICT)</li> <li>• 220 kV GIS bus duct/Cable for interconnection of 220 kV side of ICT (10<sup>th</sup>) to 220 kV GIS bay (Section-1)</li> </ul>	20.01.2029 (matching with timeframe of Transmission System for Evacuation of Power from REZ in Rajasthan (20 GW) under Phase III – Part I scheme (Pole 1))
2.	Implementation of 5 Nos. of 220 kV line bays at 765/400/220 kV Bhadla-III PS. <ul style="list-style-type: none"> <li>• 220 kV line bay – 5 Nos.</li> </ul>	
3.	Implementation of 1 No. of 400 kV line bay at 765/400/220 kV Bhadla-III PS. <ul style="list-style-type: none"> <li>• 400 kV line bay – 1 No.</li> </ul>	

Sl. No.	Scope of the Transmission Scheme	Scheduled COD in months from Effective Date
4.	Implementation of 2 sets 400 kV sectionlizer bay at 765/400/220 kV Bhadla-III PS <ul style="list-style-type: none"> <li>400 kV sectionalizer bay – 2 sets</li> </ul>	
5.	Augmentation of 765/400 kV, 2x1500 MVA (3 <sup>rd</sup> & 4 <sup>th</sup> ) ICTs at 765/400/220 kV Ramgarh PS <ul style="list-style-type: none"> <li>1500 MVA, 765/400 kV ICT - 2 Nos.</li> <li>765 kV ICT bay – 2 Nos.</li> <li>400 kV ICT bay – 2 Nos.</li> </ul>	
6.	Augmentation of 400/220 kV, 2x500 MVA (3 <sup>rd</sup> & 4 <sup>th</sup> ) ICTs at 765/400/220 kV Ramgarh PS <ul style="list-style-type: none"> <li>500 MVA, 400/220 kV ICT - 2 Nos.</li> <li>400 kV ICT bays – 2 Nos.</li> <li>220 kV ICT bay – 2 Nos.</li> </ul>	
7.	Implementation of 2 Nos. of 220 kV line bays at 765/400/220 kV Ramgarh PS <ul style="list-style-type: none"> <li>220 kV line bay – 2 Nos.</li> </ul>	
8.	Implementation of 1 No. of 400 kV line bay at 765/400/220 kV Ramgarh PS <ul style="list-style-type: none"> <li>400 kV line bay – 1 No.</li> </ul>	
9.	Augmentation of 765/400 kV, 1x1500 MVA (3 <sup>rd</sup> ) ICT at 765/400 kV Kanpur (PG) substation <ul style="list-style-type: none"> <li>1500 MVA (3x500 MVA), 765/400 kV ICT - 1 No.</li> <li>765 kV ICT bay (GIS) including completion of diameter.</li> <li>400 kV ICT bay (GIS) in existing spare bay</li> <li>All associated GIS duct with terminations.</li> </ul>	

### 1.3 Project Description

Transmission System requirement for additional 20 GW REZ in Northern Region (Phase-III) was approved in 5<sup>th</sup> NCT meeting held on 25.08.21 & 02.09.21. As part of above scheme, establishment of 765/400/220 kV Bhadla- III PS, 765/400/220 kV Ramgarh PS along with associated EHVAC system was approved in Phase-III Part B1 package & Part C1 package of scheme respectively

Further in 5<sup>th</sup> NCT meeting, it was decided that augmentation of 1x1500 MVA ICT at 765/400 kV Kanpur (GIS) substation as part of Phase-III, Part J scheme is linked with HVDC system (LILO of Varanasi-Kanpur at Fatehpur) and since the timeframe of HVDC has now been delayed, therefore, this item could also be taken up later.

Subsequently, Augmentation of 400/220 kV 2x500 MVA (4<sup>th</sup> & 5<sup>th</sup>) ICTs, Augmentation of 765/400 kV 2x1500 MVA (3<sup>rd</sup> & 4<sup>th</sup>) ICTs along with 220 kV BC & TBC bay at Bhadla-III PS was approved as part of Transmission system of “Additional Transmission system for

evacuation of power from Bhadla-III PS as part of Rajasthan REZ Phase-III scheme (20 GW)”. The scheme is also under implementation.

As Connectivity application has already been granted at Ramgarh and Bhadla-III PS. with fulfilment of connectivity grant process, additional no. of ICTs along with line bays (400 kV and 220 kV) are required for RE interconnection in matching timeframe of Transmission System for Evacuation of Power from REZ in Rajasthan (20 GW) under Phase III scheme (Bhadla-Fatehpur HVDC scheme (Pole 1)).

The scheme comprises augmentation of 400/220 kV, 5x500 MVA (6<sup>th</sup>-10<sup>th</sup>) ICTs, Implementation of 5 Nos. of 220 kV line bays & 1 No. of 400 kV line bay at 765/400/220 kV Bhadla-III PS as well as augmentation with 765/400 kV, 2x1500 MVA (3<sup>rd</sup> & 4<sup>th</sup>) ICTs, 400/220 kV, 2x500 MVA (3<sup>rd</sup> & 4<sup>th</sup>) ICTs, Implementation of 2 Nos. of 220 kV line bays & 1 No. of 400 kV line bay at 765/400/220 kV Ramgarh PS. The scope also covers augmentation with 765/400 kV, 1x1500 MVA (3<sup>rd</sup>) ICT at 765/400 kV Kanpur (PG) substation.

Augmentation at Kanpur (GIS) S/s as part of Transmission system for evacuation of power from REZ in Rajasthan (20 GW) under Phase III was agreed in the 3<sup>rd</sup> NRPC-TP meeting held on 19.02.21, 49<sup>th</sup> NRPC meeting held on 27.09.21 & 5<sup>th</sup> National Committee on Transmission (NCT) held on 25.08.21 and 02.09.21. Further, augmentation at Bhadla-III PS & Ramgarh PS is agreed in 41<sup>st</sup> CMETS-NR meeting held on 10.10.25. The composite scheme was approved in 37<sup>th</sup> NCT held on 19.01.2026. Subsequently, Ministry of Power, Government of India, vide its Gazette Notification no. CG-DL-E-19022026-270309 dated 12.02.2026 declared establishment of “Augmentation at Bhadla-III, Ramgarh PS and Kanpur (PG)” through tariff based competitive bidding process route

#### 1.4 **Transmission Grid Map**

Transmission Grid Map indicating the location of the Project is enclosed as Annexure 18 of this RFP for information and reference of the Bidders.

- 1.5 The objective of the bidding process is to select a Successful Bidder pursuant to this RFP, who shall acquire one hundred percent (100%) of the equity shares of ..... (Insert the name of SPV) along with all its related assets and liabilities as per the provisions of the Share Purchase Agreement, at the Acquisition Price to be intimated by the BPC, twenty (20) days prior to the Bid Deadline.

The ..... (Insert the name of SPV), of which one hundred percent (100%) equity shares will be acquired by the Selected Bidder, shall be responsible as the TSP, for ensuring that it undertakes ownership, financing, development, design, engineering, procurement, construction, commissioning, operation and maintenance of the Project, and to provide Transmission Service as per the terms of the RFP Project Documents.

The TSP shall ensure transfer of all project assets along with substation land, right of way and clearances to CTU or its successors or an agency as decided by the Central Government after 35 years from COD of project at zero cost and free from any encumbrance and liability. The transfer shall be completed within 90 days after 35 years from COD of project failing which CTU shall be entitled to take over the project assets *Suo moto*.

**1.6 Brief Scope of Work**

**1.6.1 Scope of Transmission Service Provider**

The TSP’s scope of work for the Project shall comprise, but not necessarily be limited to the following:

1.6.1.1 Establishment, operation and maintenance of the Project on build, own, operate and transfer basis and completion of all the activities for the Project, including survey, detailed project report formulation, arranging finance, project management, necessary Consents, Clearances and Permits (way leave, environment & forest, civil aviation, railway/ road/ river/ canal/ power crossing/ PTCC etc.). land compensation, design, engineering, equipment, material, construction, erection, testing & commissioning.

Further, the actual location of Greenfield Substations (Switching Stations or HVDC Terminal or Inverter Stations) in the scope of TSP:

- For a Generation Pooling Substation shall not be beyond 3 Km radius of the location proposed by the BPC in their Survey Report.
- For Load Serving Substation within the scope of TSP shall not be beyond 5 Km radius of the location proposed by the BPC in their Survey Report.
- For an Intermediate Substation shall not be beyond 10 Km radius of the location proposed by the BPC in their Survey Report.

1.6.1.2 The TSP shall ensure that design, construction and testing of all equipment, facilities, components and systems of the Project shall be in accordance with Transmission Service Agreement and applicable Rules/ Regulations, Orders and Guidelines issued by the Central Government.

1.6.1.3 The TSP shall ensure timely completion of entire scope of Project in all respects and its operation and maintenance, as shall be specified in the RFP documents.

1.6.1.4 The TSP shall seek Transmission License from the Commission, as per the provisions of the Electricity Act and regulations made thereunder.

1.6.1.5 The TSP shall seek approval under Section 164 of Electricity Act, from CEA after acquisition of ..... (Insert the name of SPV). The approval shall be granted by CEA generally within 30 days but in no case later than 45 days from the date of receipt of application (complete in all aspects).

**1.6.2 Scope of Bid Process Coordinator (BPC)**

BPC’s scope of work is briefly outlined hereunder:

1.6.2.1 The BPC has initiated development of the Project and shall be responsible for the tasks in this regard as specified hereunder:

1. Provide to the Bidders a Survey Report for the Project at least forty five (45) days prior to the Bid Deadline. The Survey Report shall include the suggested route with approximate route length, type of terrain likely to be encountered and its likely implication in terms of

Right of Way (ROW), statutory clearances, location of substations or converter stations and land area to be acquired for the substation or converter station.

2. To obtain approval for laying of overhead transmission lines under Section 68 of Electricity Act, from the Government at least twenty (20) days prior to Bid Deadline.
3. To initiate acquisition of land for location specific substations, switching stations or HVDC terminal or inverter stations, if required.
4. To initiate process of seeking forest clearance, if required
5. The BPC shall intimate to the Bidders, the Acquisition Price payable by the Selected Bidder to the REC Power Development and Consultancy Limited for the acquisition of one hundred percent (100%) of the equity shareholding of ..... (Insert the name of SPV), along with all its related assets and liabilities at least twenty (20) days prior to the Bid Deadline.
6. The BPC shall ensure issuance of all finalized RFP Project Documents, at least fifteen (15) days prior to the Bid Deadline.

Provided that for any delay in meeting the above obligations of the BPC within the specified time period above, the Bid Deadline as per Clause 2.7.1 shall be extended on a day for day basis.

- 1.6.2.2 The details and documents as may be obtained by the BPC/ project specific SPV in relation to the Project shall be handed over to the TSP on an as-is-where-is basis, so that it may take further actions to obtain Consents, Clearances and Permits.
- 1.7 All costs (including direct and indirect) incurred by the BPC/ project specific SPV in connection with the activities concerning the Project shall be recovered from the TSP, which shall be included in the Acquisition Price.
- 1.8 The Project is required to be completed progressively in accordance with the schedule prescribed in this RFP.
- 1.9 A company under the Companies Act, 2013 by the name ..... (Insert the name of SPV) has been incorporated to initiate the activities for execution of the Project. The said company shall be acquired by the successful Bidder as per terms and conditions as may be prescribed in RFP.
- 1.10 The Ministry of Power and the appropriate state government(s) shall provide their support to the TSP, on best endeavor basis, in enabling the TSP to develop the Project.
- 1.11 All Bidders are required to submit their Bid in accordance with the instructions set forth in this RFP.
- 1.12 Once the Successful Bidder is selected, the details and documents as may be obtained by the BPC/ project specific SPV in relation to the Project, shall be handed over to the Successful Bidder on as is where basis, so that it may take further actions to obtain all necessary Consents, Clearances and Permits and the TSP shall not be entitled for any extensions in the Scheduled COD of the Project except as provided for in the TSA.

- 1.13 The assets of the Project shall be made available on a commercial basis as per the terms and conditions of the Transmission Service Agreement and Central Electricity Regulatory Commission (Sharing of Inter-State Transmission Charges and Losses) Regulations as amended from time to time.

**SECTION - 2**

**INFORMATION AND  
INSTRUCTIONS FOR  
BIDDERS**

**SECTION – 2****2. INFORMATION AND INSTRUCTIONS FOR BIDDERS****2.1 Qualification Requirements**

- 2.1.1 The Bidder should be a company duly incorporated under the relevant laws (Bidding Company) or a Consortium of companies (Bidding Consortium) with one of the companies acting as the Lead Member of the Bidding Consortium. The Bidder shall be selected on meeting the Qualification Requirements specified in Section 2 of this RFP, as demonstrated by the Bidder's Technical Bid and the lowest Quoted Transmission Charges discovered from Final Offers quoted during the e-reverse bidding. A Bidding Consortium can participate in the bidding process for the Project if any Member of the Consortium has purchased the RFP document for such Project. Bidder who agree and undertake to procure the products associated with the Transmission System as per provisions of Public Procurement (Preference to Make in India) orders issued by Ministry of Power vide orders No. 11/5/2018 - Coord. dated 28.07.2020 as amended vide order No. A1/2021- FSC-Part(5) dated 16.11.2021 and No.: P45021/2/2017-PP (BE-II)-Part-4 Vol.II dated 19.07.2024 issued by Ministry of Power for transmission sector, as may be further amended from time to time read with Department for Promotion of Industry and Internal Trade (DPIIT) orders in this regard, shall be eligible hereunder. Further, it is clarified that Procuring Entity as defined in orders shall deemed to have included Selected Bidder and/or TSP.

Besides, Department of Expenditure, Ministry of Finance in suppression of OMs issued vide Order (Public Procurement No 1) bearing File No. 6/18/2019-PPD dated 23.07.2020, Order (Public Procurement No 2) bearing File No. 6/18/2019-PPD dated 23.07.2020 and Order (Public Procurement No. 3) bearing File No. 6/18/2019-PPD, dated 24.07.2020, Office Memorandum (OM) No. F.18/37/2020-PPD dated 08.02.2021, OM No. F.12/1/2021- PPD (Pt.) dated 02.03.2021, OM No. F.7/10/2021-PPD dated 08.06.2021 and Order (Public Procurement No 4) bearing File No. F.7/10/2021-PPD dated 23.02.2023 as amended from time to time, have issued directions regarding public procurement from a bidder of a country, which shares land border with India are also applicable.

**2.1.2 Technical requirement to be met by the Bidding Company or Lead Member of Bidding Consortium**

The Bidder must fulfill any one of the following technical requirements:

- (i) Experience of development of projects in the Infrastructure Sector in the last five (5) years with aggregate capital expenditure of not less than **Rs. 870 Crore** or equivalent USD (calculated as per provisions in Clause 3.4.1). However, the capital expenditure of each project shall not be less than **Rs. 174 Crore** or equivalent USD (calculated as per provisions in Clause 3.4.1).

For this purpose, capital expenditure incurred on projects that have been commissioned/completed at least seven (7) days prior to Bid Deadline shall be considered. The capital expenditure discussed above shall be as capitalized and reflected in the audited books of accounts of the Technically Evaluated Entity. In case a clearly identifiable part of a project has been put into commercial operation, the capital expenditure on such part of the project shall be considered.

The Technically Evaluated Entity must have either executed such projects itself or must have held directly or indirectly at least twenty six percent (26%) of the shareholding in the company that has executed the project(s) from the date of financial closure of the project(s) till the time of commissioning/completion of such project(s).

OR

- (ii) Experience in construction of project in infrastructure sector: The Technically Evaluated Entity should have received aggregate payments not less than **Rs. 870 Crore** or equivalent USD (calculated as per provisions in Clause 3.4.1) from its client(s) for construction works fully completed during the last 5(five) financial years. However, the payment received from each project shall not be less than **Rs. 174 Crore** or equivalent USD (calculated as per provisions in Clause 3.4.1).

For this purpose, payments received on projects that have been commissioned/completed at least seven (7) days prior to Bid Deadline shall be considered. Further only the payments (gross) actually received, during such 5 (five) financial years shall qualify for purposes of computing the technical capacity. For the avoidance of doubt, construction works shall not include cost of land, supply of goods or equipment except when such goods or equipment form part of a turn-key construction contract/ EPC contract for the project. Further, in cases where different individual contracts are signed between same entities for the same project, the cumulative payments received under such individual contracts shall be considered for meeting the qualification requirement.

The Technically Evaluated Entity may be the Bidding Company or the Lead Member of a Consortium or an Affiliate or Parent of such Bidding Company or the Lead Member, as the case may be.

Bidders shall furnish documentary evidence duly certified by authorized signatory of the Bidder who has been issued Power of Attorney in support of their technical capability as defined in Clause 2.1.2 of this RFP.

### 2.1.3 Financial requirement to be met by the Bidding Company/Bidding Consortium

2.1.3.1 The Bidder must fulfill following financial requirements:

#### A. Networth:

Networth should be not less than **Rs. 348 Crore** or equivalent USD (calculated as per provisions in Clause 3.4.1) computed as the Networth based on unconsolidated audited annual accounts (refer to Note below) of any of the last three (3) financial years as provided in Clause 2.2.3, immediately preceding the Bid Deadline. Also, the Networth of any of the last three (3) financial years should not be negative.

Note: Audited consolidated annual accounts of the Bidder may be used for the purpose of financial criteria provided the Bidder has at least 26% equity in each company whose accounts are merged in the audited consolidated accounts and provided further that the financial capability of such companies (of which accounts are being merged in the consolidated accounts) shall not be considered again for the purpose of evaluation of the

Technical Bid. Bidders shall furnish prescribed Annexure 7 (A) duly certified by authorized signatory of the Bidder who has been issued Power of Attorney and the Statutory Auditor and separate computation sheet for Networth duly certified by Statutory Auditor in support of their financial capability as defined in Clause 2.1.3 of this RFP.

2.1.3.2 The Networth shall be computed in the following manner by the Bidder:

**A. Networth**

=	Equity share capital
Add:	Reserves
Subtract:	Revaluation Reserves
Subtract:	Intangible Assets
Subtract:	Miscellaneous expenditures to the extent not written off and carry forward losses

2.1.3.3 If the Technical Bid is submitted by a Bidding Consortium the financial requirement shall be met individually and collectively by all the Members in the Bidding Consortium. The financial requirement to be met by each Member of the Bidding Consortium shall be computed in proportion to the equity commitment made by each of them for investment in the Project.

2.1.4 The Bidder may seek qualification on the basis of technical and financial capability of its Parent and/ or its Affiliate(s) for the purpose of meeting the Qualification Requirements. However, in the case of the Bidder being a Consortium, the Lead Member has to meet the technical requirement on its own or by seeking the technical capability of its Parent and/or its Affiliate(s). Authorization for use of such technical or financial capability shall have to be provided from its Parent and/or Affiliate(s) as per Annexure 9. The technical and financial capability of a particular company/ particular project, including its Parents and/or Affiliates, shall not be used directly or indirectly by more than one Bidder/ Member of a Bidding Consortium/ Bidding Company. However, development and construction experience of a particular project may be used by more than one company.

The determination of the relationship of Parent or Affiliate with the Bidding Company or with the Member of the Bidding Consortium, including the Lead Member, shall be on the date at the most seven (7) days prior to the last date of submission of the Bid. Documentary evidence to establish such relationship shall be furnished by the Bidder along with the Technical Bid.

If the Technically Evaluated Entity and/or Financially Evaluated Entity is an entity other than the Bidding Company or a Member in a Bidding Consortium, the Bidding Company or Member relying on such Technically Evaluated Entity and/or Financially Evaluated Entity will have to submit a legally binding undertaking supported by a board resolution from the Technically Evaluated Entity and/or Financially Evaluated Entity or its Ultimate Parent Company, that all the equity investment obligations of the Bidding Company or the Member of the Consortium shall be deemed to be equity investment obligations of the Technically Evaluated Entity and/or Financially Evaluated Entity or its Ultimate Parent Company, and in the event of any default the same shall be met by such evaluated entity or by or the Ultimate Parent Company. The Bidding Company or the Consortium Member shall have to provide information and documents relating to its relationship with such Technically Evaluated Entity and/or Financially Evaluated Entity including details about

the equity shareholding between them as per Annexure 7(C).

- 2.1.5 A Bidder shall submit only one Bid in the same bidding process, either individually as Bidding Company or as a Member of a Bidding Consortium (including the Lead Member). It is further clarified that any of the Parent/ Affiliate/Ultimate Parent of the Bidder/ Member in a Bidding Consortium shall not separately participate directly or indirectly in the same bidding process. Further, if any Bidder is having a Conflict of Interest with other Bidders participating in the same bidding process, the Bids of all such Bidders shall be rejected.
- 2.1.6 Notwithstanding anything stated above, BPC reserves the right to verify the authenticity of the documents submitted for meeting the Qualification Requirements and request for any additional information and documents. BPC reserves the right at its sole discretion to contact the Bidder's bank and project references and verify the Bidder's information and documents for the purpose of bid evaluation.
- 2.1.7 The Qualified Bidder(s) will be required to continue to maintain compliance with the Qualification Requirements throughout the bidding process and till execution of the Transmission Service Agreement. Where the Technically Evaluated Entity and/or the Financially Evaluated Entity is not the Bidding Company or a Member in a Bidding Consortium, as the case may be, the Bidding Company or Member shall continue to be an Affiliate of the Technically Evaluated Entity and/or Financially Evaluated Entity till the execution of the Transmission Service Agreement. Failure to comply with the aforesaid provisions shall make the Bid liable for rejection at any stage.
- 2.1.8 The Selected Bidder will be required to continue to maintain compliance with the Qualification Requirements till the COD of the Project. Where the Technically Evaluated Entity and/or the Financially Evaluated Entity is not the Bidding Company or a Member in a Bidding Consortium, as the case may be, the Bidding Company or Member shall continue to be an Affiliate of the Technically Evaluated Entity and/or Financially Evaluated Entity till the COD of the Project. Failure to comply with the aforesaid provisions shall be dealt as per provisions of Transmission Service Agreement.
- 2.1.9 On the Bid Deadline, for the Bidder to be eligible to participate in the bidding process:
- a. the Bidder & any of its Affiliate including any Consortium Member & any of its Affiliate, their directors or key personnel should not have been barred or included in the blacklist by any government agency or authority in India, the government of the jurisdiction of the Bidder or Members where they are incorporated or the jurisdiction of their principal place of business, any international financial institution such as the World Bank Group, Asian Development Bank, African Development Bank, Inter-American Development Bank, Asian Infrastructure Investment Bank etc or the United Nations or any of its agencies; or
  - b. the Bidder & any of its Affiliate including any Consortium Member & any of its Affiliate or their directors should not have been convicted of any offence in India or abroad.

In case any investigation is pending against the Bidder, including any Consortium Member or Affiliate, or CEO or any of the directors/ manager/key managerial personnel of the Bidder /Consortium /Member or their Affiliates, full details of such investigation

including the name of the investigating agency, the charge/offence for which the investigation has been launched, name and designation of persons against whom the investigation has been launched and other relevant information should be disclosed while submitting the Bid.

The Bidders shall confirm the above through a notarized affidavit as per Annexure 22.

## **2.2 Submission of Bid by the Bidder**

2.2.1 The information and documents in Technical Bid will be submitted by the Bidder as per the formats specified in Section – 4 (Formats for RFP) of this document

2.2.2 Strict adherence to the formats wherever specified, is required. Wherever, information has been sought in specified formats, the Bidder shall refrain from referring to brochures/pamphlets. Non-adherence to formats and/ or submission of incomplete information may be a ground for declaring the Technical Bid as non-responsive. Each format has to be duly signed and stamped by the authorized signatory of Bidder.

2.2.3 The Technical Bid shall contain unconsolidated/consolidated audited annual accounts (consisting of unabridged Balance Sheet, Profit and Loss Account, profit appropriation account, Auditors Report, etc.), as the case may be, of Bidding Company or each Member in Consortium including Lead Member or the Financially Evaluated Entity for the last three (3) financial years immediately preceding the last date for submission of Bid for the purpose of calculation of Networth.

In case the annual accounts for the financial year immediately preceding the Bid Deadline is not audited, the Bidder shall give declaration in this regard duly certified by its statutory auditor. In such a case, the Bidder shall provide the audited annual accounts for the three (3) financial years preceding the financial year as above for which the annual accounts have not been audited.

### **2.2.4 Bid submitted by a Bidding Consortium:**

2.2.4.1 The Technical Bid shall contain a legally enforceable Consortium Agreement entered amongst the Members in the Bidding Consortium, designating one of the Members to be the Lead Member (as per Annexure 6). There shall be only one Lead Member which shall continue to hold twenty six percent (26%) equity in the TSP and cannot be changed upto one (1) year from the Commercial Operation Date (COD) of the Project. Each Member in Bidding Consortium shall duly sign the Consortium Agreement making it liable for raising the required funds for its respective equity investment commitment as specified in the Consortium Agreement. In absence of Consortium Agreement, the Technical Bid will not be considered for evaluation and will be rejected.

Provided that the Lead Member of the Bidding Consortium will be required to be liable to the extent of 100% of the total proposed commitment of equity investment of the Bidding Consortium i.e. for both its own equity contribution as well as the equity contribution of other Members.

Provided further that the Consortium Agreement shall not be amended without the explicit approval of the BPC.

The Lead Member of the Consortium will be the single point of contact for the purposes of the bid process before the date of signing of Share Purchase Agreement. Settlement of any dispute amongst the Consortium Members shall not be the responsibility of the BPC and/or the CTU and the BPC and/or the CTU shall not bear any liability whatsoever on this account.

- 2.2.4.2 The Lead Member should designate at the most two persons to represent the Consortium in its dealings with the BPC. The person(s) designated by the Lead Member should be authorized through a Power of Attorney (as per Annexure 3) to perform all tasks including, but not limited to providing information, responding to enquiries, signing of Technical Bid on behalf of the Consortium, etc. The Bidding Consortium shall provide board resolutions from their respective Boards for committing their respective portion of equity requirement for the Project. Additionally, the Lead member shall provide a Board resolution committing to make good any shortfall in the equity for the project, in case of any member not meeting its equity commitment.
- 2.2.4.3 The Technical Bid should also contain signed Letter of Consent (as per Annexure 2) from each Member in Consortium confirming that the entire Technical and Financial Bids has been reviewed and each element of the Technical and Financial Bids is agreed to by them including investment commitment for the Project.

In addition, the Technical Bid should also contain Board Resolution from each Member of the Consortium other than the Lead Member in favour of their respective authorized representatives for executing the POA, Consortium Agreement and signing of the requisite formats.

### 2.2.5 Bid submitted by a Bidding Company

- 2.2.5.1 The Bidding Company should designate at the most two persons to represent the Bidding Company in its dealings with BPC. The person(s) should be authorized to perform all tasks including, but not limited to providing information, responding to enquiries, signing of Technical and Financial Bids etc. The Bidding Company should submit, along with Technical Bid, a Power of Attorney (as per Annexure 3), authorizing the signatory of the Technical and Financial Bids. The Bidding Company shall submit the board resolution committing 100% of equity requirement for the Project, in the Technical Bid.

## 2.3 Clarifications & Pre-Bid Meeting

- 2.3.1 The Bidders may seek clarifications or suggest amendments to the RFP by sending an email to the BPC at the email id indicated in Clause 2.14 within the date and time mentioned in Clause 2.7.2. For any such clarifications or amendments, the Bidders should adhere to the format as per Annexure – 19.
- 2.3.2 Only those Bidders or their authorized representatives, who have purchased the RFP documents are invited to attend the pre-bid meeting(s), which will take place on date as specified in Clause 2.7.2, or any such other date as notified by the BPC. The time and address of this would be intimated later.
- 2.3.3 The purpose of the pre-bid meeting will be to clarify any issues regarding the RFP, including in particular, issues raised in writing by the Bidders as per the provisions of Clause 2.3.1.

- 2.3.4 Non-attendance at the pre-bid meeting will not be a cause for disqualification of a Bidder.
- 2.3.5 The BPC is not under any obligation to entertain / respond to suggestions made or to incorporate modifications sought for.
- 2.3.6 In case Bidders need any further clarifications not involving any amendments in respect of final RFP, they should ensure that request for such clarification is submitted through e-mail to the BPC at least ten (10) days prior to the Bid Deadline as mentioned in Clause 2.7.1. The BPC may issue clarifications only, as per its sole discretion, which is considered reasonable by it. Any such clarification issued shall be sent to all the Bidders to whom the RFP has been issued. Clarifications sought after this date shall not be considered in any manner and shall be deemed not to have been received. There shall be no extension in Bid Deadline on account of clarifications sought as per this clause 2.3.6.

## **2.4 Amendment of RFP**

- 2.4.1. At any time before the timeline mentioned in Clause 2.7.1, the BPC may, for any reason, whether at its own initiative or in response to clarifications requested by any Bidder modify or amend the RFP, including the timelines specified in Clause 2.7.2 by issuance of addendum/modification/errata and/or revised document. Such document shall be notified in writing through a letter or fax or e-mail to all the entities to which the RFP has been issued and shall be binding on them. In order to ensure that Bidders have reasonable time to take the modification into account in preparing their Bid, or for any other reasons, BPC may at its discretion, extend the due date for submission of Bid. Late receipt of any addendum/modification/errata and/or revised document will not relieve the Bidder from being bound by that modification.
- 2.4.2. All modifications shall become part of the terms and conditions of this RFP. No interpretation, revision or communication regarding this RFP is valid, unless made in writing.
- 2.4.3. The amendment to the RFP shall be notified to all the Bidders through the electronic bidding platform and shall be binding on them.

## **2.5 The Bidding Process**

The entire bidding process shall be conducted on electronic bidding platform created by MSTC Limited. The Bid shall comprise of the Technical Bid and the Financial Bid. The Bidders shall submit the Technical Bid & Financial Bid through the electronic bidding platform. In addition to the online submission, the Bidder with lowest Final Offer will be required to submit original hard copies of Annexure 3, Annexure 4 (if applicable), Annexure 6 (if applicable) and Annexure 14/14A/14B before issuance of LoI. There shall be no physical submission of the Financial Bid.

Evaluation of Technical Bid will be carried out considering the information and documents furnished by the Bidders as required under this RFP. This step would involve responsiveness check, technical and financial evaluation of the details/ documents furnished by the Bidding Company / Bidding Consortium in support of meeting the Qualification Requirements. Bidders meeting the Qualification Requirements, subject to evaluation as specified in Clause 3.2 to 3.4 shall be declared as “Qualified Bidders” and

eligible for opening of Initial Offer. The BPC shall also upload the list of all Qualified Bidders and Non-Qualified Bidders on the bidding portal along with the reasons for non-qualification. Also, the Financial Bids of Qualified Bidders shall be opened after at least 24 hours from the date of declaration of the Technically Qualified Bidders.

The Financial Bid will comprise of two rounds. In the first round the Initial Offer (submitted online along with the Technical Bids) of the responsive bids would be opened and Quoted Transmission Charges of Initial Offer shall be ranked on the basis of ascending order for determination of the Qualified Bidders as provided in Section-III of RFP. The Qualified Bidders, in the first fifty per cent of the ranking (with any fraction rounded off to higher integer) or four Qualified Bidders, whichever is higher, shall qualify for participating in the electronic reverse auction stage and submit their Final Offer.

Provided however, in case only one Bidder remains after the evaluation of Technical Bid as per Clause 3.2, 3.3 and Clause 3.4, the Initial Offer of such Bidder shall not be opened and the matter shall be referred to the Government.

Provided that in the event the number of qualified Technical Bids is between two and four, then each of the qualified Bidder shall be considered as “Qualified Bidders”.

Provided that in the event of identical Quoted Transmission Charges discovered from the Initial Offer having been submitted by one or more Bidders, all such Bidders shall be assigned the same rank for the purposes of determination of Qualified Bidders. In such cases, all the Qualified Bidders who share the same rank till 50% of the rank (with any fraction rounded off to higher integer) determined above, shall qualify to participate in the electronic e-reverse auction stage. In case 50% of the ranks (with any fraction rounded off to higher integer) is having less than 4 (four) Bidders and the rank of the fourth (4<sup>th</sup>) Bidder is shared by more than one (1) Bidder, then all such Bidders who share the rank of the fourth (4<sup>th</sup>) Bidder shall qualify to participate in the electronic reverse auction.

The applicable ceiling for electronic reverse bidding shall be the lowest Quoted Transmission Charges discovered from the Initial Offer received from the Qualified Bidders. The Qualified Bidders shall be permitted to place their Final Offer on the electronic bidding platform, which is lower than zero point two five (0.25) % of the prevailing lowest Quoted Transmission Charges.

The initial period for conducting the e-reverse bidding should be 2 hours which will be extended by 30 minutes from the last received bid time, if the bid is received during the last 30 minutes of the scheduled or extended bid time. Subsequently, it will be extended again by 30 minutes from the latest received bid time.

The technical details with respect to access to such electronic platform are provided in Annexure-A (Technical Details with respect to electronic reverse auction).

In case of any technical clarification regarding access to the electronic reverse auction platform or conduct of the auction process, the Bidders may contact MSTC Limited directly at the address provided in Annexure-A.

### 2.5.1 Bid Formats

The Bids in response to this RFP will be submitted online through the electronic bidding platform by the Bidders in the manner provided in Clause 2.9. The Bids shall comprise of the following:

**2.5.2 Technical Bid comprising of:**

1. Covering Letter (as per prescribed format enclosed as **Annexure 1**);
2. Letter of Consent from Consortium Members in **Annexure 2**;
3. Power of attorney issued by the Bidding Company or the Lead Member of the Consortium, as the case may be, in favour of the person signing the Bid, in the format attached hereto as **Annexure 3**.

Additionally, in case of a Bidding Consortium, the power of attorney in favour of the Lead Member issued by the other Members of the Consortium shall be provided in as per format attached hereto as **Annexure 4**. Further, the Lead Member shall furnish Board resolution(s) from each Member of the Consortium other than the Lead Member in favour of their respective authorized representatives for executing the POA and signing of the requisite formats.

Provided that in the event the Bidding Company or the Lead Member of the Consortium or any Member of the Bidding Consortium, as the case may be, is a foreign entity, it may issue Board resolutions in place of power of attorney for the purpose of fulfilling these requirements.

4. Bidder's composition and ownership structure in **Annexure 5**
5. Format for Authorization submitted in Non-Judicial stamp paper duly notarized as per **Annexure 5** from the Bidding Company / each Member of the Consortium authorizing the BPC to seek reference from their respective bankers & others.
6. In case of Bidding Consortium, the Consortium Agreement shall be provided in as per format attached hereto as **Annexure 6**
7. Format of Qualification Requirement (**Annexures 7A, 7B, 7C and 7D**)
8. Bidders Undertakings and details of equity investment in Project (as per prescribed formats 1 and 2 of **Annexure 8**);
9. Authorization from Parent / Affiliate of Bidding Company / Member of Bidding Consortium whose technical / financial capability has been used by the Bidding Company / Member of Bidding Consortium (**Annexure 9**).
10. Undertaking from the Technically / Financially Evaluated Entity(ies) **OR** Undertaking from the Ultimate Parent Company, for total equity investment commitment, in the prescribed format in **Annexure – 10**, to meet any shortfall in the equity investment by the Selected Bidder in the ..... (Insert the name of SPV).

**Note:** The effective Equity holding of the Selected Bidder in the ..... (Insert

the name of SPV), as specified in Clause 2.5.8.1 shall be computed as per the provisions of Clause 2.5.8.3 of this RFP.

Provided further, in case the Bidding Company or Member of a Consortium, (as the case may be) holds at least twenty six percent (26%) equity in such Technically/ Financially Evaluated Entities, whose credentials have been considered for the purpose of meeting the Qualification Requirements as per the RFP, no such Undertaking shall be required from the Technically / Financially Evaluated Entities.

11. Board resolutions, as per prescribed formats enclosed as Annexure – 11, duly certified by the Company Secretary or any Whole-time Director / Manager (supported by a specific Board Resolution), as applicable to the Bidder and mentioned hereunder,
  - (a) Board resolution from the Bidding Company (and any investing Affiliate / Parent Company / Ultimate Parent Company) committing one hundred percent (100%) in aggregate of the equity requirement for the Project - Format-1 of **Annexure 11**;
  - (b) Board resolutions from each of the Consortium Member of the Bidding Consortium (and any investing Affiliate / Parent Company / Ultimate Parent Company) together committing to one hundred percent (100%) in aggregate of equity requirement for the Project, in case Bidder is a Bidding Consortium - Format-1 of **Annexure 11**;
  - (c) In either of the cases as in (a) or (b) above as applicable, Board resolutions as per Format 2 of **Annexure 11** for total equity investment commitment from the Technically / Financially Evaluated Entity(ies) whose technical / financial credentials had been considered for the purpose of meeting Qualification Requirements as per the RFP

**OR**

Board resolutions as per Format 2 of **Annexure 11** from the Parent Company or the Ultimate Parent Company for total equity investment commitment.

Provided that such Board resolutions, as specified in (a) or (b) or (c) above, in case of a foreign entity, shall be supported by an unqualified opinion issued by an independent legal counsel practicing in the relevant country, stating that the Board resolutions are in compliance with the applicable laws of the respective jurisdictions of the issuing company and the authorizations granted therein are true and valid.

For clarity sake, illustrations identifying which Board Resolution shall be applicable in typical cases are provided in **Annexure 11A**.

12. Format for Illustration of Affiliates at the most seven (7) days prior to Bid Deadline, duly certified by Company Secretary and supported by documentary evidence (**Annexure 12**).

Certified copy of the Register of Members / Demat Account Statement, Share Certificate, Annual Return filed with ROC etc. submitted as documentary evidence along with **Annexure 12**.

13. Disclosure as per **Annexure 13** regarding participation of any related companies in this bidding process.
14. Bid Bond, as per the prescribed format at **Annexure 14** or **Annexure 14A** or **Annexure 14B**;
15. Checklist for Technical Bid submission requirements as per **Annexure 16**.
16. Last three (3) financial years' unconsolidated / consolidated audited annual accounts / statements, as the case may be, of the Financially Evaluated Entity / Technical Evaluated Entity
17. Unconsolidated audited annual accounts of both the TEE and the Bidding Company/Lead member, as applicable, for the financial years in which financial closure was achieved and the financial year in which the said project was completed / commissioned.
18. Copy of the Memorandum and Articles of Association and certificate of incorporation or other organizational document (as applicable), including their amendments, certified by the Company Secretary of Bidding Company or each Member in case of a Consortium including Lead Member.
19. For each project listed in Annexure 7(D), certified true copy of the certificates of final acceptance and / or certificates of good operating performance duly issued by owners or clients for the project, duly signed by authorized signatory.

In addition to the online submission of above formats through the electronic platform, the Bidder with lowest Final Offer will be required to submit original hard copies of Annexure 3, Annexure 4 (if applicable), Annexure 6 (if applicable) and Annexure 14/14A/14B before issuance of LoI. In case, there is a discrepancy between the online submission and physical documents, the bid would be outrightly rejected and the bidder shall be construed to have engaged in the fraudulent practice as defined in Clause 2.19.3 with consequences as mentioned in Clause 2.19.2.

### **2.5.3 Financial Bid (as per prescribed format at Annexure-21)**

Financial Bid shall comprise of: (i) the Initial Offer; and (ii) the Final Offer. The Initial Offer is required to be submitted along with the Technical Bid. It is hereby clarified that the Financial Bid will comprise of two rounds. In the first round the Initial Offer of the responsive bids would be opened and Quoted Transmission Charges of Initial Offer shall be ranked on the basis of ascending order for determination of the Qualified Bidders as provided in Section-III of RFP.

In accordance with clause 2.5 of this RFP, the qualified Bidders shall be eligible to participate in the electronic reverse auction and submit their Final Offer.

The applicable ceiling for electronic reverse bidding shall be the lowest Quoted Transmission Charges discovered from the Initial Offer received from the Qualified Bidders. The Qualified Bidders shall be permitted to place their Final Offer on the

electronic bidding platform, which is lower than zero point two five (0.25) % of the prevailing lowest Quoted Transmission Charges.

The initial period for conducting the e-reverse bidding should be 2 hours which will be extended by 30 minutes from the last received bid time, if the bid is received during the last 30 minutes of the scheduled or extended bid time. Subsequently, it will be extended again by 30 minutes from the latest received bid time.

The Bidders shall inter-alia take into account the following while preparing and submitting the Initial Offer and Final Offer of Financial Bid :-

- a. The Bidders shall quote single annual Quoted Transmission Charges for a period of 35 years commencing from the Scheduled COD of the Project.
- b. The Quoted Transmission Charges as per the format at Annexure-21 shall be inclusive of all charges and no exclusions shall be allowed. The Bidders shall take into account all costs including capital and operating, statutory taxes, duties, levies. Availability of the inputs necessary for operation and maintenance of the Project should be ensured by the TSP at the Project site and all costs involved in procuring the inputs (including statutory taxes, duties, levies thereof) at the Project site must be included in the Quoted Transmission Charges.
- c. Annexure 21 duly digitally signed by authorized signatory.

2.5.4 Wherever information has been sought in specified formats, the Bidders shall fill in the details as per the prescribed formats and shall refrain from referring to any other document for providing any information required in the prescribed format.

### **2.5.5 Transmission Charges**

- 2.5.5.1. The Transmission Charges shall be specified in the Transmission Service Agreement and shall be payable to the TSP in Indian Rupees only. The Bidders shall quote single Transmission Charges as per the format at Annexure – 21.
- 2.5.5.2. The Transmission Charges of the Selected Bidder shall be inserted in Schedule 5 of the Transmission Service Agreement.

### **2.5.6 Bidders may note that:**

- a) All the information and documents in Bid shall be submitted in English language only.
- b) Bidders shall mention the name, designation, telephone number, fax number, email address of the authorized signatory and complete address of the Bidder in the covering letter.
- c) All pages of the Bid submitted shall be initialed and stamped by the authorized signatory on behalf of the Bidder.
- d) A Bidder shall submit only one Bid in the same bidding process, either individually as Bidding Company or as a Member of a Bidding Consortium.

- e) The technical and financial capability of a particular company / particular project (Parent and/ or Affiliate) shall not be used directly or indirectly by more than one Bidder/ Member of a Bidding Consortium including Lead Member / Bidding Company.
- f) This Request for Proposal (RFP) document is not transferable. The RFP document and the information contained therein is for the use only by the Bidder to whom it is issued. It may not be copied or distributed by the recipient to third parties (other than in confidence to the recipient's professional advisors). In the event that the recipient does not continue with its involvement in the Project, this RFP document must be kept confidential.
- g) Though adequate care has been taken while preparing this RFP document, the Bidder shall satisfy himself that the document is complete in all respects. Intimation of any discrepancy shall be given to the BPC immediately. If no intimation is received from any Bidder within ten (10) days from the date of issue of RFP document, it shall be considered that the RFP document is complete in all respects and has been received by the Bidder.
- h) Bids submitted by the Bidder and opened on scheduled date and time as stipulated in this RFP shall become the property of the BPC and BPC shall have no obligation to return the same to the Bidder.
- i) If any Bidder conceals any material information or makes a wrong statement or misrepresents facts or makes a misleading statement in its Bid, in any manner whatsoever, the BPC reserves the right to reject such Bid or cancel the Letter of Intent, if issued. If such event is discovered after the Effective Date, consequences specified in Transmission Service Agreement shall apply.
- j) If for any reason the Bid of the Bidder with the lowest Quoted Transmission Charges is not selected or Letter of Intent issued to such Selected Bidder is cancelled or such Bidder withdraws its Bids, the BPC may :-
- i. Invite all the remaining Bidders to revalidate or extend their respective Bid Security, as necessary, and match the Bid of the Bidder with the lowest Quoted Transmission Charges (the "second round of bidding") with following cases:
    - If in the second round of bidding, only one Bidder matches the Bid of the Bidder with lowest Quoted Transmission Charges, it shall be the Selected Bidder.
    - If two or more Bidders match the Bid of the Bidder with the lowest Quoted Transmission Charges in the second round of bidding, then the Bidder whose Quoted Transmission Charges was lower as compared to other Bidder(s) in the first round of bidding shall be the Selected Bidder. For example, if the third and fifth lowest Bidders in the first round of bidding offer to match the Bid of the Bidder with lowest Quoted Transmission Charges in the second round of bidding, the said third lowest Bidder shall be the Successful Bidder.
    - In the event that no Bidder offers to match the Bid of the Bidder with the lowest Quoted Transmission Charges in the second round of bidding, the BPC may, in its discretion, invite fresh Bids (the "third round of bidding") from all Bidders

except the Bidder which quoted the lowest Quoted Transmission Charges in the first round of bidding. In case the Bidders are invited for the third round of bidding to revalidate or extend their Bid Security, as necessary, and offer fresh Bids, they shall be eligible for submission of fresh Bids provided, however, that in such third round of bidding only such Bids shall be eligible for consideration which are lower than the Quoted Transmission Charges of the second lowest Bidder in the first round of bidding; or;

- ii. Annul the bid process; or
- iii. Take any such measure as may be deemed fit in the sole discretion of the BPC<sup>1</sup>
- k) The BPC may, at its sole discretion, ask for additional information / document and/or seek clarifications from a Bidder after the Bid Deadline, inter alia, for the purposes of removal of inconsistencies or infirmities in its Bid. However, no change in the substance of the Quoted Transmission Charges shall be sought or permitted by the BPC.
- l) Non submission and/or submission of incomplete data/ information required under the provisions of RFP shall not be construed as waiver on the part of BPC of the obligation of the Bidder to furnish the said data / information unless the waiver is in writing.
- m) Bidders shall familiarize itself with the procedures and time frames required to obtain all Consents, Clearances and Permits.
- n) All Bidders are required to ensure compliance with the standards and codes mentioned in Clause 1.6.1.2.
- o) BPC reserves the right to reject all Bids and/or annul the process of tariff based competitive bidding for selection of Bidder as TSP to execute the Project without assigning any reason. BPC shall not bear any liability, whatsoever, in this regard.
- p) Foreign companies submitting the Bid are required to follow the applicable law in their country for execution of POA, Consortium Agreement and affixation of Common Seal (wherever required) and in such cases, their Bid should be supported by an unqualified opinion issued by an independent legal counsel practicing in the relevant country, stating that execution of such POA, Consortium Agreement and the authorizations granted therein are true and valid. Foreign companies executing POA outside India shall necessarily pay the adequate stamp charges in India as per the provisions of Stamp Act.

## 2.5.7 Bidders to inform themselves fully

- 2.5.7.1. The Bidders shall make independent enquiry and satisfy themselves with respect to all the required information, inputs, conditions and circumstances and factors that may have any effect on his Bid. Once the Bidders have submitted their Bids, the Bidders shall be deemed to have inspected and examined the site conditions (including but not limited to its surroundings, its geological condition and the adequacy of transport facilities to the site), the laws and regulations in force in India, the transportation facilities available in India, the grid conditions, the adequacy and conditions of roads, bridges, railway sidings,

<sup>1</sup> BPC shall record reasons for the same.

ports, etc. for unloading and/or transporting heavy pieces of material and has based its design, equipment size and fixed its price taking into account all such relevant conditions and also the risks, contingencies and other circumstances which may influence or affect the transmission of power. Accordingly, each Bidder acknowledges that, on being selected as Successful Bidder and on acquisition of one hundred percent (100%) of the equity shares of the ..... (Insert the name of SPV), the TSP shall not be relieved from any of its obligations under the RFP Project Documents nor shall the TSP be entitled to any extension in Scheduled COD mentioned in this RFP or financial compensation for any reason whatsoever.

- 2.5.7.2. In their own interest, the Bidders are requested to familiarize themselves with all relevant laws of India, including without limitation, the Electricity Act 2003, the Income Tax Act 1961, the Companies Act, 1956 / Companies Act, 2013 (as the case may be), Environment Protection Act 1986 and Forest (Conservation) Act, 1980, the Customs Act, the Foreign Exchange Management Act, Land Acquisition Act, 1894, the Indian Telegraph Act 1885, Labor & Employment Laws of India, [Insurance Act] the regulations/standards framed by the Commissions and CEA, all other related acts, laws, rules and regulations prevalent in India, as amended from time to time.

In addition to the above, the Bidders are required to familiarize themselves with all relevant technical codes and standards, including but not limited to the Grid Code / State Grid Code, Central Electricity Authority (Installation and Operations of Meters) Regulations, 2006, Central Electricity Authority (Technical Standards for Connectivity to the Grid) Regulations, 2007, Central Electricity Regulatory Commission Grant of Connectivity, Long-term Access and Medium - Term Open Access in Inter-State Transmission and related matters) Regulations, 2009, Central Electricity Authority (Technical Standards for construction of Electrical Plants and Electric Lines) Regulation, 2010, Central Electricity Authority (Technical Standards for Communication System in Power System Operation) Regulations, 2020, Central Electricity Regulatory Commission (Sharing of Inter-State Transmission Charges and Losses) Regulations, 2020 and other relevant Rules/ Regulations/ Guidelines issued by the Central Government, the CERC and the CEA and amendments thereof.

The BPC shall not entertain any request for clarifications from the Bidders regarding the above laws / acts / rules / regulations / standards. Non-awareness of the same shall not be a reason for the Bidder to request for extension in Bid Deadline. The Bidders undertake and agree that, before submission of their Bid, all such factors as generally brought out above, have been fully investigated and considered while submitting their Bids.

- 2.5.7.3. The Survey Report has been prepared in good faith, and on best endeavor basis. Neither BPC & Nodal Agency nor their employees or advisors/consultants make any representation or warranty, express or implied, or accept any responsibility or liability, whatsoever, in respect of any statements or omissions made in the Survey Report, or the accuracy, completeness or reliability of information contained therein, and shall incur no liability under any law, statute, rules or regulations as to the accuracy, reliability or completeness of such Survey Report, even if any loss or damage is caused to the Bidders by any act or omission on their part.
- 2.5.7.4. Bidders shall make best efforts and carry out its own due diligence upon survey report provided by BPC and shall consider all possible techno-commercial factors before submission of Bid. Bidders may also visit the route of the Transmission Lines associated

with the Project and the surrounding areas and obtain / verify all information which they deem fit and necessary for the preparation of their Bid. Bidders may also carry out required surveys and field investigation for submission of their Bid. Bidders may also opt for any other route and is not bound to follow the route suggested in survey report provided by BPC.

- 2.5.7.5. Failure to investigate, examine and to inspect site or subsurface conditions fully shall not be grounds for a Bidder to alter its Bid after the Bid Deadline nor shall it relieve a Bidder from any responsibility for appropriately eliminating the difficulty or costs of successfully completing the Project.
- 2.5.7.6. The Selected Bidder shall obtain all necessary Consents, Clearances and Permits as required. The Bidders shall familiarize itself with the procedures and time frame required to obtain such Consents, Clearances and Permits.
- 2.5.7.7. The technical requirements of integrated grid operation are specified in the Indian Electricity Grid Code (IEGC). The Bidders should particularly acquaint themselves with the requirements of connection conditions, operating code for regional grids, scheduling and dispatch instructions/codes, etc. The Bidders are also advised to fully familiarize themselves with the real time grid conditions in the country. Information regarding grid parameters such as voltage and frequency is available on the websites of Regional / State Load Despatch Centers.

**2.5.8 Minimum Equity holding/Equity Lock-in**

- 2.5.8.1. (a) The aggregate equity share holding of the Selected Bidder, in the issued and paid-up equity share capital of ..... (Insert the name of SPV) shall not be less than Fifty one percent (51%) up to a period of (1) one year after COD of the Project;
- (b) In case the Selected Bidder is a Bidding Consortium, then any Member (other than the Lead Member) of such Bidding Consortium shall be allowed to divest its equity as long as the other remaining Members (which shall always include the Lead Member) hold the minimum equity specified in (a) above.
- (c) If equity is held by the Affiliates, Parent Company or Ultimate Parent Company, then subject to the second proviso of this Clause 2.5.8.1 (c), such Affiliate, Parent Company or Ultimate Parent Company shall be permitted to transfer its shareholding in ..... (Insert the name of SPV) to another Affiliate or to the Parent Company / Ultimate Parent Company. If any such shareholding entity, qualifying as an Affiliate / Parent Company / Ultimate Parent Company, is likely to cease to meet the criteria to qualify as an Affiliate / Parent Company / Ultimate Parent Company, the shares held by such entity shall be transferred to another Affiliate / Parent Company / Ultimate Parent Company.

Provided that in case the Lead Member or Bidding Company is holding equity through Affiliate/s, Ultimate Parent Company or Parent Company, such restriction shall apply to such entities.

Provided further, that the aggregate equity share holding of the Bidding Consortium or a Bidding Company in the issued and paid-up equity share capital of ..... (Insert the name of SPV) shall not be less than fifty one percent (51%) up to a period of one (1) year after COD of the Project and the lead Member of the Consortium shall have the

equity share holding not less than twenty six percent (26%). In case the Selected Bidder is a Bidding Consortium, then any Member (other than the Lead Member) of such Bidding Consortium shall be allowed to divest its equity as long as the other remaining Members (which shall always include the Lead Member) hold the minimum equity specified in (a) above.

(d) All transfer(s) of shareholding ..... (Insert the name of SPV) by any of the entities referred to above, shall be after prior written intimation to the Nodal Agency.

2.5.8.2. The Selected Bidder may invest in the equity share capital of ..... (Insert the name of SPV) through its Affiliate(s) or Ultimate Parent Company or Parent Company. Details of such investment will have to be specified in the Technical Bid as per Format 2 of Annexure 8 of the RFP. If the Selected Bidder so invests through any Affiliate(s) or Ultimate Parent Company or Parent Company, the Selected Bidder shall be liable to ensure that minimum equity holding/lock-in limits specified in Clause 2.5.8.1 and as computed as per the provisions of Clause 2.5.8.3 are still maintained.

2.5.8.3. For computation of effective Equity holding, the Equity holding of the Selected Bidder or its Ultimate Parent Company in such Affiliate(s) or Parent Company and the equity holding of such Affiliate (s) or Ultimate Parent Company in ..... (Insert the name of SPV) shall be computed in accordance with the example given below:

If the Parent Company or the Ultimate Parent Company of the Selected Bidder A directly holds thirty percent (30%) of the equity in ..... (Insert the name of SPV) then holding of Selected Bidder A in ..... (Insert the name of SPV) shall be thirty percent (30%);

If Selected Bidder A holds thirty percent (30%) equity of the Affiliate and the Affiliate holds fifty percent (50%) equity in ..... (Insert the name of SPV), then for the purposes of ascertaining the minimum equity/equity lock-in requirements specified above, the effective holding of Bidder A in ..... (Insert the name of SPV) shall be fifteen percent (15%), (i.e.,  $30\% * 50\%$ );

2.5.8.4. The provisions as contained in this Clause 2.5.8 and Article 19.1 of the Transmission Service Agreement shall override the terms of the Consortium Agreement submitted by the Bidder as part of the RFP.

## 2.6 Project Schedule

2.6.1. All Elements of the Project are required to be commissioned progressively as per the schedule given in the following table;

Sl. No.	Name of the Transmission Element	Scheduled COD*	Percentage of Quoted Transmission Charges recoverable on Scheduled COD of the Element of the Project**	Element(s) which are pre-required for declaring the commercial operation (COD) of the respective element
1.	Augmentation of 400/220 kV, 5x500 MVA (6 <sup>th</sup> to 10 <sup>th</sup> ) ICTs at 765/400/220 kV Bhadla-III PS	20.01.2029 (matching with timeframe of Transmission System for Evacuation of Power from REZ in Rajasthan (20 GW) under Phase III – Part I scheme (Pole 1))	36.4%	These elements of the scheme are required to be commissioned simultaneously as their utilization is dependent on each other.
2.	Implementation of 5 Nos. of 220 kV line bays at 765/400/220 kV Bhadla-III PS.			
3.	Implementation of 1 No. of 400 kV line bay at 765/400/220 kV Bhadla-III PS.			
4.	Implementation of 2 sets 400 kV sectionlizer bay at 765/400/220 kV Bhadla-III PS			
5.	Augmentation of 765/400 kV, 2x1500 MVA (3 <sup>rd</sup> & 4 <sup>th</sup> ) ICTs at 765/400/220 kV Ramgarh PS		39.6%	These elements of the scheme are required to be commissioned simultaneously as their utilization is dependent on each other.
6.	Augmentation of 400/220 kV, 2x500 MVA (3 <sup>rd</sup> & 4 <sup>th</sup> ) ICTs at 765/400/220 kV Ramgarh PS			
7.	Implementation of 2 Nos. of 220 kV line bays at 765/400/220 kV Ramgarh PS			
8.	Implementation of 1 No. of 400 kV line bay at 765/400/220 kV Ramgarh PS			
9.	Augmentation of 765/400 kV, 1x1500 MVA (3 <sup>rd</sup> ) ICT			
			24%	Utilization of this Element is independent

Sl. No.	Name of the Transmission Element	Scheduled COD*	Percentage of Quoted Transmission Charges recoverable on Scheduled COD of the Element of the Project**	Element(s) which are pre-required for declaring the commercial operation (COD) of the respective element
	at 765/400 kV Kanpur (PG) substation			

The payment of Transmission Charges for any Element irrespective of its successful commissioning on or before its Scheduled COD shall only be considered after successful commissioning of the Element(s) which are pre-required for declaring the commercial operation of such Element as mentioned in the above table.

**Scheduled COD for overall Project:** 20.01.2029 (matching with timeframe of Transmission System for Evacuation of Power from REZ in Rajasthan (20 GW) under Phase III-Part I scheme (Pole 1)).

Note: List of Element(s) along with the critical Element(s) to be provided by CEA.

## 2.7 Due dates

- 2.7.1. The Bidders should submit the Bids online through the electronic bidding platform before the Bid Deadline i.e. on or before 1500 hours (IST) on 28.05.2026. In addition to the online submission, the Bidder with lowest Final Offer will be required to submit original hard copies of Annexure 3, Annexure 4 (if applicable), Annexure 6 (if applicable) and Annexure 14/14A/14B before issuance of LoI.
- 2.7.2. Important timelines are mentioned below:

Date	Event
25.03.2026	Issuance of RFP
14.04.2026	Submission of written clarifications/amendments, if any, on the RFP / RFP Project Documents by Bidders so as to reach BPC by 1700 hours. Such written clarifications/amendments shall be in the format provided in Annexure-20.
16.04.2026	Pre-Bid meeting(s)
04.05.2026	Issue of written clarifications and revised RFP documents
12.05.2026	Issue of final RFP Project Documents
28.05.2026	Submission of Bid (Online submission of Bid through electronic bidding portal)
28.05.2026	Opening of Technical Bid
04.06.2026	Short listing and announcement of Qualified Bidders on bidding portal
08.06.2026	Opening of Financial Bid - Initial Offer
09.06.2026	Electronic reverse auction (Financial Bid – Final Offer) for the Qualified Bidders.
12.06.2026	Submission of original hard copies of Annexure 3, Annexure 4, Annexure 6, as applicable and Annexure 14/14A/14B by the bidder with lowest Final Offer
17.06.2026	Selection of Successful Bidder and issue of LOI
29.06.2026	Signing of RFP Project Documents and transfer of ..... (Insert the name of SPV)

- 2.7.3. To enable BPC to meet the schedule, all Bidders are expected to respond expeditiously during the bidding process. If any milestone/activity falls on a day which is not a working day or which is a public holiday then the milestone/activity shall be achieved/ completed on the next working day.

## 2.8 Validity of the Bid

- 2.8.1. The Bid shall remain valid for a period of one hundred and eighty (180) days from the Bid Deadline. The BPC reserves the right to reject any Bid which does not meet aforementioned validity requirement.
- 2.8.2. The BPC may solicit the Bidders' consent for an extension of the period of validity of the Bid. The request and the response, thereafter, shall be in writing. In the event any Bidder refuses to extend its Bid validity as requested by the BPC, the BPC shall not be entitled to invoke the Bid Bond. A Bidder accepting the BPC's request for validity extension shall not be permitted to modify its Bid and such Bidder shall, accordingly, extend the validity of the Bid Bond as requested by the BPC within seven (7) days of

such request, failing which the Bid shall not be considered as valid.

**2.9 Method of Submission**

- 2.9.1. Both the Technical and Financial Bids duly filled in, all formats and supporting shall be scanned and uploaded online through electronic bidding platform in the manner specified in Annexure A
- 2.9.2. It may be noted that Technical Bid shall not contain any information/document relating to Financial Bid. If Technical Bid contains any such information/documents, the BPC shall not be responsible for premature opening of the Financial Bid.

All pages of the Bid, except for the Bid Bond (Annexure 14/14A/14B) and any other document executed on non-judicial stamp paper, forming part of the Bid and corrections in the Bid, if any, must be signed by the authorized signatory on behalf of the Bidder. It is clarified that the same authorized signatory shall sign all pages of the Bid. However, any published document submitted in this regard shall be signed by the authorized signatory at least on the first and last page of such document.

- 2.9.3. No change or supplemental information to a Bid already submitted will be accepted after the Bid Deadline, unless the same is requested for by the BPC as per Clause 2.5.6 (k).

Provided that a Bidder shall always have the right to withdraw / modify its Bid before the Bid Deadline. No Technical Bid or Initial Offer shall be modified, substituted or withdrawn by the Bidder on or after the Bid Deadline.

**2.10 Preparation cost**

- 2.10.1. The Bidders shall be responsible for all the costs associated with the preparation of the Bid and participation in discussions and attending pre-bid meetings, and finalization and execution of the RFP Project Documents (other than the TSA), etc. BPC shall not be responsible in any way for such costs, regardless of the conduct or outcome of the process of tariff based competitive bidding for selection of Bidder as TSP as per Bidding Guidelines.
- 2.10.2. The cost of this RFP is Rupees Five Lakh Only (Rs. 5,00,000) or U.S. Dollar Seven Thousand Only (US\$ 7,000) plus GST as per applicable rate, which shall be non-refundable. This amount shall be paid via electronic transfer to the following Bank Account:

Bank Name, Address & Branch	ICICI Bank 9A, Phelps Building, Inner Circle, Connaught Place, New Delhi-110001
Bank Account Name	REC Power Development & Consultancy Limited
Bank Account No	000705041275
Bank IFSC Code No	ICIC0000007

Immediately after issuance of RFP document, the Bidder shall submit the Pre-Award Integrity Pact in the format as prescribed in Annexure B, which shall be applicable for and during the bidding process, duly signed on each page by any whole-time Director / Authorized Signatory, duly witnessed by two persons, and shall be submitted by the Bidder in two (2)

originals in a separate envelope, duly superscripted with Pre-Award Integrity Pact. The Bidder shall submit the Pre-Award Integrity Pact on non-judicial stamp paper of Rs. 100/- each duly purchased from the National Capital Territory of Delhi. In case the Bidder is in a consortium, the Pre-Award Integrity Pact shall be signed and submitted by each member of the Consortium separately.

## 2.11 Bid Bond

2.11.1. Each Bidder shall submit the Bid accompanied by Bid Bond issued by any of the Banks listed in Annexure-17. The Bid Bond shall be valid for a period of thirty (30) days beyond the validity of the Bid.

2.11.2. Subject to the provisions of Clause 2.15.5, the Bid Bond may be invoked by the BPC or its authorized representative, without any notice, demure, or any other legal process upon occurrence of any of the following:

- Bidder withdraws during the period of Bid Validity as specified in this RFP or as extended by mutual consent of the respective Bidder(s) and the BPC
- Failure to execute the Share Purchase Agreement as per the provisions of Clause 2.15.2; or
- Failure to furnish the Contract Performance Guarantee as per Clause 2.12; or
- Failure to acquire one hundred percent (100%) equity shares of ..... (Insert the name of SPV), along with all its related assets and liabilities, in accordance with the provisions of Clause 2.15.2; or
- Failure to comply with the provisions of Clause 2.15.5 and Clause 2.15.6, leading to annulment of the award of the Project.
- Bidders submitting any wrong information or making any misrepresentation in their Bid as mentioned in Clause 2.5.6.

Intimation of the reasons of the invocation of the Bid Bond shall be given to the Selected Bidder by the BPC within three (3) working days after such invocation.

2.11.3. The Bid Bond of the Selected Bidder shall be returned on submission of the Contract Performance Guarantee as per Clause 2.12 and the relevant provisions of the Transmission Service Agreement.

2.11.4. The Bid Bond of all the Bidders, whose Bids are declared non-responsive, shall be returned within a period of thirty (30) days after the date on which the Financial Bids are opened.

2.11.5. The Bid Bond of all unsuccessful Bidders shall be returned and released by the BPC on the same day on which the ..... (Insert the name of SPV) is transferred to the Selected Bidder. The Bid Bond of the Successful Bidder shall be returned on submission of Contract Performance Guarantee as per Clause 2.12 of this RFP and the provisions of the Transmission Service Agreement.

## 2.12 Contract Performance Guarantee

2.12.1. Within ten (10) days from the date of issue of the Letter of Intent, the Selected Bidder, on behalf of the TSP, will provide to the Nodal Agency the Contract Performance Guarantee for an amount of Rs. 43.50 Crore (Rupees Forty-Three Crore and Fifty Lakhs Only). The Contract Performance Guarantee shall be initially valid for a period up to three (3) months after the Scheduled COD of the Project and shall be extended from time to time to be valid for a period up to three (3) months after the COD of the Project and thereafter shall be dealt with in accordance with the provisions of the Transmission Service Agreement. The Contract Performance Guarantee shall be issued by any of the banks listed in Annexure-17 as per format given at Annexure- 15 or any of the insurance companies authorized by Insurance Regulatory and Development Authority of India as per format given at Annexure-15A or PFC/REC/IREDA as per Payment on Order Instrument format given at Annexure-15B

2.12.2. In case the Selected Bidder is unable to obtain the Contract Performance Guarantee for the total amount from any one bank specified in Annexure-17, the Selected Bidder may obtain the same from not more than three (3) banks specified in Annexure-17.

### **2.13 Opening of Bids**

2.13.1. Technical Bid will be opened by the Bid Opening Committee as per the following time schedule and in the office of Central Electricity Authority, in the online presence of Bidders' representatives who wish to attend:

Opening of Envelope (Technical Bid): 1530 hours (IST) on 28.05.2026

or such other dates as may be intimated by BPC to the Bidders.

In the event of any of above dates falling on a day which is not a working day or which is a public holiday, then the bids shall be opened on the next working day at the same venue and time.

Opening of Initial Offer: Initial Offer shall be opened by the Bid Opening Committee in presence of the Bid Evaluation Committee at 1530 hours (IST) on 08.06.2026 in the office of CEA.

2.13.2. The following information from each Bid will be read out to all the Bidders at the time of opening of Technical Bid:

- Name of the Bidding Company / Consortium Members in case of Bidding Consortium.

#### **Information to be provided after opening of Initial Offer:**

Only the lowest Initial Offer (s) shall be communicated to all the Qualified Bidders to participate in the e-reverse bidding process. During the e-reverse bidding process only the lowest prevailing bid should be visible to all the bidders on the electronic platform.

### **2.14 Enquiries**

Written clarifications on the RFP and other RFP Project Documents as per Clause 2.3 and 2.4 may be sought from:

Chief Executive Officer,  
REC Power Development and Consultancy Limited  
(A wholly owned subsidiary of REC Limited)  
REC Corporate Head Quarter,  
D Block, Plot No. I – 4,  
Sec – 29 Gurugram – 122 001  
Email: vijay.kulkarni@recpdcl.in & tbc@recpdcl.in

## 2.15 Other Aspects

2.15.1. The draft of the Transmission Service Agreement has been attached to this RFP. In addition to above, the following documents have also been attached to this RFP:

a) Share Purchase Agreement

When the drafts of the above RFP Project Documents are provided by the BPC, these RFP Project Documents shall form part of this RFP as per Formats – 1 & 2 of Annexure 20.

Upon finalization of the RFP Project Documents after incorporating the amendments envisaged in Clause 2.4 of this RFP, all the finalized RFP Project Documents shall be provided by BPC to the Bidders at least fifteen (15) days prior to the Bid Deadline.

The Transmission Service Agreement and Share Purchase Agreement shall be signed in required number of originals so as to ensure that one (1) original is retained by each party to the Agreement(s) on the date of transfer of SPV.

2.15.2. Within ten (10) days of the issue of the Letter of Intent, the Selected Bidder shall:

- a) provide the Contract Performance Guarantee in favour of the Nodal Agency as per the provisions of Clause 2.12;
- b) execute the Share Purchase Agreement and the Transmission Service Agreement;
- c) acquire, for the Acquisition Price, one hundred percent (100%) equity shareholding of ..... (Insert the name of SPV) from REC Power Development and Consultancy Limited, who shall sell to the Selected Bidder, the equity shareholding of ..... (Insert the name of SPV), along with all its related assets and liabilities;

Stamp duties payable on purchase of one hundred percent (100%) of the equity shareholding of ..... (Insert the name of SPV), along with all its related assets and liabilities, shall also be borne by the Selected Bidder.

Provided further that, if for any reason attributable to the BPC, the above activities are not completed by the Selected Bidder within the above period of ten (10) days as mentioned in this Clause, such period of ten (10) days shall be extended, on a day for day basis till the end of the Bid validity period.

- 2.15.3. After the date of acquisition of the equity shareholding of ..... (Insert the name of SPV), along with all its related assets and liabilities, by the Selected Bidder,
- i. the authority of the BPC in respect of this Bid Process shall forthwith cease and any actions to be taken thereafter will be undertaken by the Nodal Agency,
  - ii. all rights and obligations of ..... (Insert the name of SPV), shall be of the TSP,
  - iii. any decisions taken by the BPC prior to the Effective Date shall continue to be binding on the Nodal Agency and
  - iv. contractual obligations undertaken by the BPC shall continue to be fulfilled by the TSP.
  - v. Further, the TSP shall execute the Agreement(s) required, if any, under Central Electricity Regulatory Commission (Sharing of Inter-State Transmission Charges and Losses) Regulations as amended from time to time.
- 2.15.4. Within five (5) working days of the issue of the acquisition of the SPV by the Successful Bidder, the TSP shall apply to the Commission for grant of Transmission License and make an application to the Commission for the adoption of Transmission Charges, as required under Section – 63 of The Electricity Act 2003.
- 2.15.5. If the Selected Bidder / TSP fails or refuses to comply with any of its obligations under Clauses 2.15.2, 2.15.3 and 2.15.4, and provided that the other parties are willing to execute the Share Purchase Agreement and REC Power Development and Consultancy Limited is willing to sell the entire equity shareholding of ..... (Insert the name of SPV), along with all its related assets and liabilities, to the Selected Bidder, such failure or refusal on the part of the Selected Bidder shall constitute sufficient grounds for cancellation of the Letter of Intent. In such cases, the BPC / its authorized representative(s) shall be entitled to invoke the Bid Bond of the Selected Bidder.
- 2.15.6. If the TSP fails to obtain the Transmission License from the Commission, it will constitute sufficient grounds for annulment of award of the Project.
- 2.15.7. The annulment of award, as provided in Clauses 2.15.5 and 2.15.6 of this RFP, will be done by the Government on the recommendations of National Committee on Transmission. However, before recommending so, National Committee on Transmission will give an opportunity to the Selected Bidder / TSP to present their view point.
- 2.15.8. The annulment of the award, under Clause 2.15.5 or 2.15.6 of this RFP, shall be sufficient grounds for blacklisting the bidder, whose award has been annulled, for a period of five years or more, as decided by the National Committee on Transmission, provided that the blacklisting shall be done only after giving the bidder an opportunity for showing cause.

## 2.16 Confidentiality

- 2.16.1. The parties undertake to hold in confidence this RFP and RFP Project Documents and not to disclose the terms and conditions of the transaction contemplated hereby to third parties,

except:

- a) to their professional advisors;
- b) to their officers, contractors, employees, agents or representatives, financiers, who need to have access to such information for the proper performance of their activities;
- c) disclosures required under Law, without the prior written consent of the other parties of the concerned agreements.

Provided that the TSP agrees and acknowledges that the Nodal Agency may at any time, disclose the terms and conditions of the RFP and RFP Project Documents to any person, to the extent stipulated under the Law or the Bidding Guidelines.

## **2.17 Right of the BPC to reject any Bid**

BPC reserves the right to reject all or any of the Bids/ or cancel the RFP without assigning any reasons whatsoever and without any liability.

**2.18** Non submission and/or submission of incomplete data/ information required under the provisions of RFP shall not be construed as waiver on the part of BPC of the obligation of the Bidder to furnish the said data / information unless the waiver is in writing.

## **2.19 Fraudulent and Corrupt Practices**

2.19.1. The Bidders and their respective officers, employees, agents and advisers shall observe the highest standard of ethics during the Bid process and subsequent to the issue of the LoI Notwithstanding anything to the contrary contained herein, or in the LoI, the BPC shall reject a Bid, withdraw the LoI, as the case may be, without being liable in any manner whatsoever to the Bidder, if it determines that the Bidder has, directly or indirectly or through an agent, engaged in corrupt practice, fraudulent practice, coercive practice, undesirable practice or restrictive practice in the Bid process. In such an event, the BPC shall forfeit the Bid Bond, without prejudice to any other right or remedy that may be available to the BPC hereunder or otherwise.

2.19.2. Without prejudice to the rights of the BPC under Clause 2.19.1 hereinabove and the rights and remedies which the BPC may have under the LoI, if a Bidder is found by the BPC to have directly or indirectly or through an agent, engaged or indulged in any corrupt practice, fraudulent practice, coercive practice, undesirable practice or restrictive practice during the Bid process, or after the issue of the LoI, such Bidder & its Affiliates shall not be eligible to participate in any tender or RFP issued by any BPC for an indefinite period from the date such Bidder is found by the BPC to have directly or indirectly or through an agent, engaged or indulged in any corrupt practice, fraudulent practice, coercive practice, undesirable practice or restrictive practices, as the case may be.

2.19.3. For the purposes of this Clause 2.19, the following terms shall have the meaning hereinafter respectively assigned to them:

- a) **“corrupt practice”** means (i) the offering, giving, receiving, or soliciting, directly or indirectly, of anything of value to influence the actions of any person connected

with the Bid process (for avoidance of doubt, offering of employment to or employing or engaging in any manner whatsoever, directly or indirectly, any official of the BPC who is or has been associated or dealt in any manner, directly or indirectly with the Bid process or the LoI or has dealt with matters concerning the Transmission Service Agreement or arising there from, before or after the execution thereof, at any time prior to the expiry of one year from the date such official resigns or retires from or otherwise ceases to be in the service of the BPC, shall be deemed to constitute influencing the actions of a person connected with the Bid Process); or (ii) engaging in any manner whatsoever, whether during the Bid Process or after the issue of the LoI or after the execution of the Transmission Service Agreement, as the case may be, any person in respect of any matter relating to the Project or the LoI or the Transmission Service Agreement, who at any time has been or is a legal, financial or technical adviser of the BPC in relation to any matter concerning the Project;

- b) **"Fraudulent practice"** means a misrepresentation or omission of facts or suppression of facts or disclosure of incomplete facts, in order to influence the Bid process;
- c) **"Coercive practice"** means impairing or harming, or threatening to impair or harm, directly or indirectly, any person or property to influence any person's participation or action in the Bid process;
- d) **"undesirable practice"** means (i) establishing contact with any person connected with or employed or engaged by the BPC with the objective of canvassing, lobbying or in any manner influencing or attempting to influence the Bid process; or (ii) having a Conflict of Interest; and
- e) **"Restrictive practice"** means forming a cartel or arriving at any understanding or arrangement among Bidders with the objective of restricting or manipulating a full and fair competition in the Bid process.

**SECTION - 3**

**EVALUATION OF THE  
TECHNICAL AND  
FINANCIAL BID**

## SECTION 3

**1. EVALUATION OF BID****3.1. The evaluation process of Technical Bid comprises the following five steps:**

- Step I – Responsiveness check
- Step II- Compliance with submission requirements
- Step III– Evaluation of Technical Bids
- Step IV– Evaluation of Financial Bids
- Step V – Bidder Selection

**3.2. STEP I – Responsiveness check**

The Technical Bid submitted by the Bidder shall be initially scrutinized to establish “Responsiveness”. Subject to clause 2.5.6 (k), any of the following conditions shall cause the Technical Bid to be “Non-responsive”:

- a) Technical Bid that are incomplete.
- b) Technical Bid not signed by authorized signatory and / or stamped in the manner indicated in this RFP.
- c) All pages of the Technical Bid submitted but not initialed by the authorized signatories on behalf of the Bidder.
- d) Technical Bid not including the covering letter as per Annexure 1.
- e) Technical Bid submitted by a Bidding Consortium not including the Consortium Agreement.
- f) Technical Bid contains material inconsistencies in the information and documents submitted by the Bidder, affecting the Qualification Requirements.
- g) Bidder submitting or participating in more than one Bid either as a Bidding Company or as a Member of Bidding Consortium.
- h) More than one Member of the Bidding Consortium or a Bidding Company using the credentials of the same Parent/Affiliate.
- i) Information not submitted in formats specified in the RFP.
- j) Applicable Board resolutions, or any other document, as provided in Clause 2.5.2, not being submitted;
- k) Bid not accompanied by a valid Bid Bond;
- l) Non submission of power of attorney, supported by a Board resolution;
- m) Bid validity being less than that required as per Clause 2.8 of this RFP;
- n) Bid not containing Format-1 (Bidders' Undertakings) of Annexure-8;

- o) Bidder having Conflict of Interest
- p) The Bidder has not submitted a disclosure as per Annexure 13.
- q) Bidders delaying in submission of additional information or clarifications sought by the BPC.
- r) If the Bidder makes any misrepresentation as specified in Clause 3.7.
- s) Bid being conditional in nature.
- t) More than one Member of the Bidding Consortium or a Bidding Company using the credentials of the same Parent/Affiliate.

### **3.3. STEP II - Compliance with submission requirements**

Each Bidder's Technical Bid shall be checked for compliance with the submission requirements set forth in this RFP before the evaluation of Technical Bid is taken up. Annexure 16 and Annexure 11A shall be used to check whether each Bidder meets the stipulated requirements.

### **3.4. STEP III -Evaluation of Technical Bid**

Evaluation of Technical Bid will be carried out considering the information and documents furnished by the Bidders as required under this RFP. This step would involve technical and financial evaluation of the details/ documents furnished by the Bidding Company / Bidding Consortium in support of meeting the Qualification Requirements

#### **3.4.1. Interpolation of financial data.**

For the Qualification Requirements data provided by the Bidders in foreign currency, equivalent rupees of Net-worth will be calculated using bills selling exchange rates (card rate) USD/INR of State Bank of India prevailing on the date of closing of the accounts for the respective financial year as certified by their Banker.

For the purpose of calculating the aggregate capital expenditure/construction experience of the projects completed/ commissioned where such projects are executed outside India and capital expenditure is denominated in foreign currency, bills selling exchange rates (card rate) USD/INR of State Bank of India prevailing on the date of closing of the financial year in which the projects were completed and as certified by their Banker shall be considered.

For the projects executed in the current financial year bills selling (card rate) USD/INR of State Bank of India prevailing on seven (7) days prior to the last date of submission of Technical Bid and as certified by their Banker shall be considered.

For currency other than USD, Bidders shall convert such currency into USD as per the exchange rates certified by their Banker prevailing on the relevant date and used for such conversion. Such Bidders shall submit necessary certification from their Banker for the exchange rate used in the conversation.

If the exchange rate for any of the above dates is not available, the rate for the immediately available previous day shall be taken into account.

3.4.2. Bidders meeting the Qualification Requirements, subject to evaluation as specified in Clauses 3.2 to 3.4 shall be declared as Qualified Bidders and eligible for opening of Initial Offer.

3.4.3. The BPC shall upload the list of all Qualified Bidders and Non-Qualified Bidders on the bidding portal along with the reasons for non-qualification.

### **3.5. STEP IV - Evaluation of Financial Bids**

3.5.1. The Bids which have been found Qualified by the BPC, based on the Steps I to III as specified above in Clauses 3.2 to 3.4, shall be opened and Quoted Transmission Charges of such Initial Offer shall be ranked on the basis of the ascending Initial Offer submitted by each Qualified Bidder.

Based on such ranking of the Qualified Bidders, in the first fifty per cent of the ranking (with any fraction rounded off to higher integer) or four Qualified Bidders, whichever is higher, shall qualify for participating in the electronic reverse auction.

Provided however, in case only one Bidder remains after the Evaluation of Technical Bid (Steps 1 to III) as per Clause 3.2 to 3.4, the Initial Offer of such Bidder shall not be opened and the matter shall be referred to the Government.

Provided that in the event the number of Qualified Bidders is between two and four, then each of the responsive Bidder shall be considered as Qualified Bidders.

Provided that in the event of identical Quoted Transmission Charges discovered from the Initial Offer having been submitted by one or more Bidders, all such Bidders shall be assigned the same rank for the purposes of determination of Qualified Bidders. In such cases, all Qualified Bidders who share the same rank till 50% of the rank (with any fraction rounded off to higher integer) determined above, shall qualify to participate in the electronic reverse auction stage. In case 50% of the rank is having less than four (4) Bidders and the rank of the fourth (4<sup>th</sup>) Bidder is shared by more than one Bidder, then all such all such Bidders who share the rank of the fourth Bidder shall qualify to participate in the electronic reverse auction.

3.5.2. The Financial Bids comprising of both Initial Offer and Final Offer submitted by the Bidders shall be scrutinized to ensure conformity with the provisions of Clause 2.5.3 of this RFP. Any Bid not meeting any of the requirements as per Clause 2.5.3 of this RFP may cause the Bid to be considered "Non-responsive", at the sole decision of the BPC. Financial Bid not in conformity with the requirement of SI. No. (c) of Clause 2.5.3 of this RFP shall be rejected.

3.5.3 The Bidders shall quote the single annual Quoted Transmission Charges as specified in the format at Annexure – 21.

### 3.6. STEP V - Bidder Selection

3.6.1. The prevailing lowest Quoted Transmission Charges discovered from Final Offers shall only be displayed during the e-reverse bidding and the Bidder quoting such Final Offer will always remain anonymous during the e-reverse bidding. The Bidder with the prevailing lowest Quoted Transmission Charges discovered from Final Offers at the close of the scheduled or extended period of e-reverse bidding as mentioned in clause 2.5 shall be declared as the Successful Bidder, subject to verification of the original hard copies of Annexure 3, Annexure 4 (if applicable), Annexure 6 (if applicable) and Annexure 14/14A/14B. The Letter of Intent shall be issued to such Successful Bidder in two (2) copies.

However, if no bid is received during the e-reverse bidding stage then the Bidder with lowest quoted initial transmission charges ("Initial Offer") during e-bidding stage shall be declared as the Successful Bidder, subject to verification of the original hard copies of Annexure 3, Annexure 4 (if applicable), Annexure 6 (if applicable) and Annexure 14/14A/14B. The Letter of Intent shall be issued to such Successful Bidder in two (2) copies.

In case, there is a discrepancy between the online submission and physical documents, the bid would be outrightly rejected and the bidder shall be construed to have engaged in the fraudulent practice as defined in Clause 2.19.3 with consequences as mentioned in Clause 2.19.2. Further, in such a case, the provisions of Clause 2.5.6 (j) shall apply.

3.6.2. The Selected Bidder shall unconditionally accept the LoI, and record on one (1) copy of the LoI, "Accepted unconditionally", under the signature of the authorized signatory of the Successful Bidder and return such copy to the BPC within seven (7) days of issue of LoI.

3.6.3. If the Successful Bidder, to whom the Letter of Intent has been issued, does not fulfill any of the conditions specified in Clauses 2.15.2, 2.15.3 and Clause 2.15.4, then subject to Clause 2.15.5, the BPC reserves the right to annul the award of the Project and cancel the Letter of Intent. Further, in such a case, the provisions of Clause 2.5.6 (j) shall apply.

3.6.4. The BPC, in its own discretion, has the right to reject all Bids if the Quoted Transmission Charges are not aligned to the prevailing prices.

### 3.7. Misrepresentation by the Bidder

If the Bidder conceals any material information or makes a wrong statement or misrepresents facts or makes a misleading statement in the Technical Bid or Bid, as the case may be, in any manner whatsoever, in order to create circumstances for the acceptance of its Technical Bid/Bid, the BPC reserves the right to reject such Technical Bid/Bid, and/ or cancel the Letter of Intent, if issued. Further, in case Letter of Intent is cancelled, consequences as per provisions of the RFP shall follow.

### 3.8. Disposition of Technical Bid

3.8.1. Technical Bid found to be Non-responsive as per Clause 3.2, due to any of the following conditions, shall be liable for rejection.

- Technical Bid that is incomplete.
- Technical Bid not signed by authorized signatory and / or stamped in the manner indicated in this RFP.

- All pages of the Technical Bid submitted but not initialed by the authorized signatories on behalf of the Bidder.
- Technical Bid not including the covering letter as per Annexure 1.
- Technical Bid contains material inconsistencies in the information and documents submitted by the Bidder, affecting the Qualification Requirements.
- Information not submitted in formats specified in the RFP.
- The Bidder has not submitted a disclosure as per Annexure 13.
- Bidders delaying in submission of additional information or clarifications sought by the BPC.

3.8.2. Technical Bid found to be Non-responsive as per Clause 3.2, due to any of the following conditions, shall be rejected.

- Technical Bid not received by the scheduled date and time.
- Technical Bid submitted by a Bidding Consortium not including the Consortium Agreement.
- Bidder submitting or participating in more than one response either as a Bidding Company or as a Member of Bidding Consortium.
- More than one Member of the Bidding Consortium or a Bidding Company using the credentials of the same Parent/Affiliate.
- Technical Bid having Conflict of Interest.
- If the Bidder makes any misrepresentation as specified in Clause 3.7.

3.9. BPC reserves the right to interpret the Bid in accordance with the provisions of this RFP document and make its own judgment regarding the interpretation of the same. In this regard, BPC shall have no liability towards any Bidder and no Bidder shall have any recourse to BPC with respect to the qualification process.

BPC shall evaluate Bid using the process specified in Clause 3.1 to 3.6, at its sole discretion. BPC's decision in this regard shall be final and binding.

# **SECTION - 4**

# **ANNEXURES FOR BID**

## SECTION – 4

**I. Formats for Bid**

The following formats are required to be included in the Bidder's Technical and Financial Bid. These formats are designed to demonstrate the Bidder's compliance with the Qualification Requirements set forth in Clause 2.1 of Section – 2.

**Technical Bid**

1. Format for the Covering Letter
2. Format for Letter of Consent from Consortium Members
3. Format for evidence of authorized signatory's authority (Power of Attorney)
4. Format for Power of Attorney from to be provided by each of the other Members of the Consortium in favor of the Lead Member
5. Format for Bidder's composition and ownership structure and Format for Authorization
6. Format for Consortium Agreement
7. Formats for Qualification Requirement
8. Format of Bidders Undertaking and details of Equity Investment
9. Authorization from Parent/Affiliate of Bidding Company/Member of Bidding Consortium whose technical/financial capability has been used by the Bidding Company/Member of Bidding Consortium.
10. Undertaking from the Technically / Financially Evaluated Entity(ies) or from Ultimate Parent Company for equity investment
11. Format of Board Resolutions
12. Format for Illustration of Affiliates
13. Format for Disclosure
- 14A. Format of the Surety Bond for Bid Security
- 14B. Format of Payment on Order Instrument to be issued by IREDA/REC/PFC
15. Format for Contract Performance Guarantee
- 15A. Format for Surety Insurance Contract
- 15B. Format for issuance of Payment on Order Instrument
16. Checklist for Technical Bid submission requirements
22. Format for Affidavit

In addition to the online submission, the Bidder with lowest Final Offer will be required to submit original hard copies of Annexure 3, Annexure 4 (if applicable), Annexure 6 (if applicable) and Annexure 14/14A/14B before issuance of LoI.

**Financial Bid**

21. Format for Financial Bid
- II. The following formats are for the information to the Bidders to enable them to submit their Bid.
- 11A. Illustration For Applicable Board Resolution Requirements Under Clause 2.5.2
  17. List of Banks
  18. GRID Map of the Project
  19. Format for clarification/amendments on the RFP/RFP Project Documents
  20. Formats for RFP Project Documents

Bidder may use additional sheets to submit the information for its detailed Bid.

**ANNEXURE 1 - COVERING LETTER**

**(The covering letter should be on the Letter Head of the Bidding Company/ Lead Member of the Consortium)**

Date: .....  
From: .....  
.....  
.....  
Tel. No.: .....  
Fax No.: .....  
E-mail address: .....

To,

**Chief Executive Officer,  
REC Power Development and Consultancy Limited  
(A wholly owned subsidiary of REC Limited)  
REC Corporate Head Quarter,  
D Block, Plot No. I – 4,  
Sec – 29 Gurugram – 122 001**

Dear Sir,

**Sub: Bid for selection of Bidder as Transmission Service Provider to establish Inter-State Transmission System for “Augmentation at Bhadla-III, Ramgarh PS and Kanpur (PG)” through tariff based competitive bidding process.**

1. Being duly authorized to present and act on behalf of M/s ..... (insert name of Bidding Company / Bidding Consortium) (hereinafter called the “Bidder”) and having read and examined in detail the Request for Proposal (RFP) document, the undersigned hereby submit our Technical Bid with duly signed formats and Financial Bid (Initial Offer) as stipulated in RFP document for your consideration.
2. It is confirmed that our Bid is consistent with all the requirements of submission as stated in the RFP document and subsequent clarifications/amendments as per Clause 2.3 and 2.4 of RFP.
3. The information submitted in our Bid is complete, is strictly as per the requirements stipulated in the RFP document and is correct to the best of our knowledge and understanding. We would be solely responsible for any errors or omissions in our Bid.
4. We hereby agree and undertake to procure the products associated with the Transmission System as per provisions of Public Procurement (Preference to Make in India) orders issued by Ministry of Power vide orders No. 11/5/2018 - Coord. dated 28.07.2020 for transmission sector, as amended vide order No. A-1/2021-FSC- Part(5) dated 16.11.2021 and No.: P45021/2/2017-PP (BE-II)-Part-4 Vol.II dated 19.07.2024 issued by Ministry of Power for transmission sector, as may be further amended from time to time read with Department for Promotion of Industry and Internal Trade (DPIIT) orders in this regard.

We hereby also agree and undertake to comply with Department of Expenditure, Ministry of Finance revised OM dated 23.02.2023 issued in suppression of Order (Public Procurement No 1) bearing File No. 6/18/2019-PPD dated 23.07.2020, Order (Public Procurement No 2) bearing File No. 6/18/2019-PPD dated 23.07.2020 and Order (Public Procurement No. 3) bearing File No. 6/18/2019-PPD, dated 24.07.2020, Office Memorandum (OM) No. F.18/37/2020-PPD dated 08.02.2021, OM No. F.12/1/2021- PPD (Pt.) dated 02.03.2021, OM No. F.7/10/2021-PPD dated 08.06.2021 and Order (Public Procurement No 4) bearing File No. F.7/10/2021-PPD dated 23.02.2023 as amended from time to time, regarding public procurement from a bidder of a country, which shares land border with India.

5. We hereby agree to comply with Ministry of Power order no. 25-11/6/2018 – PG dated 02.07.2020 as amended from time to time.
6. We are herewith submitting legally binding board resolution for the total equity requirement of the Project.
7. We hereby confirm that in accordance with Clause 2.1.4 of the RFP, we are herewith submitting legally binding undertaking supported by a board resolution from the ..... (Insert name of Technically Evaluated Entity and/or Financially Evaluated Entity or its Ultimate Parent Company, as the case may be) that all the equity investment obligations of ..... (Insert name of the Bidding Company) shall be deemed to be equity investment obligations of the ..... (Insert name of Technically Evaluated Entity and/or Financially Evaluated Entity or its Ultimate Parent Company, as the case may be) and in the event of any default by..... (Insert name of the Bidding Company), the same shall be met by ..... (Insert name of Technically Evaluated Entity and/or Financially Evaluated Entity or its Ultimate Parent Company, as the case may be).

**[Sl. No 7 to be inserted only in case the Bidder is a Bidding Company / Lead Member of a Consortium and has sought qualification on the basis of technical and financial capability of its Affiliate(s) and/or its Parent]**

8. We confirm that there are no litigations or disputes against us, which materially affect our ability to fulfill our obligations with regard to the Project.
9. We hereby confirm that we shall continue to maintain compliance with Qualification Requirements till the execution of the Transmission Service Agreement. Further, in case we emerge as Selected Bidder for the Project, we shall continue to maintain compliance with Qualification Requirements till the COD of the Project.
10. We confirm that we have studied the provisions of relevant Indian laws and regulations required to enable us to build, own, operate and transfer the said Project and to prepare this Bid.
11. We hereby confirm that we shall abide unreservedly with BPC's decision in the qualification process for selection of Qualified Bidder and further warrant that under no circumstances we shall challenge either the BPC's decision or its right to make such decision at any time in the future.

- 12. We confirm that the Bid shall remain valid for a period of one eighty (180) days from the Bid Deadline.
- 13. The details of contact person are furnished as under:
  - Name: .....
  - Designation: .....
  - Name of the Company: .....
  - Address of the Bidder: .....
  - Phone Nos.: .....
  - Fax Nos.: .....
  - E-mail address: .....

**14. Bid Bond**

We have enclosed a Bid Bond of Rupees ..... Crores (Rs. ....) only or US\$..... (US Dollars), in the form of bank guarantee no.....[Insert number of the Bank Guarantee] dated.....[Insert Date of the Bank Guarantee] as per your proforma (Annexure-14) from.....[Insert name of bank providing Bid Bond] and valid up to .....in terms of Clause 2.11 of the RFP or in the form of insurance surety bond no..... [Insert number of the Insurance Surety Bond] dated..... [Insert Date of the Insurance Surety Bond] as per your proforma (Annexure-14A) from..... [Insert name of Insurance Company providing Insurance Surety bond] and valid up to .....in terms of Clause 2.11 of the RFP or in the form of Payment on order instrument no. .... [Insert number of the Instrument] dated..... [Insert Date of the Instrument] as per your proforma (Annexure-14B from) from..... [Insert name of company issuing Payment on Order Instrument] and valid up to.....in terms of Clause 2.11 of the RFP.

**15. Acceptance**

We hereby unconditionally and irrevocably agree and accept that the decision made by the BPC on any matter regarding or arising out of the RFP shall be binding on us. We hereby expressly waive any and all claims in respect of Bid process.

**16. Familiarity With Relevant Indian Laws & Regulations**

We confirm that we have studied the provisions of relevant Indian laws and regulations as required to enable us to submit this Bid and execute the RFP Project Documents (other than TSA), in the event of our selection as the TSP. We further undertake and agree that all such factors as mentioned in Clause 2.5.7 of RFP have been fully examined and considered while submitting the Bid.

It is confirmed that our Bid is consistent with all the requirements of submission as stated in the RFP and subsequent communications from BPC.

The information submitted in our Bid is complete, strictly as per the requirements stipulated in the RFP and is correct to the best of our knowledge and understanding. We would be solely responsible for any errors or omissions in our Bid.

We confirm that we have not taken any deviation so as to be deemed non-responsive with respect to the provisions stipulated at Clause 2.5.1, of this RFP.

Thanking you,

Yours sincerely,

.....  
**(Name and Signature of the authorized signatory in whose name Power of Attorney/ Board Resolution as per Clause 2.5.2 is issued)**

Name: .....

Designation: .....

Address: .....

Date: .....

Place: .....

**Company Rubber Stamp**

**ANNEXURE 2 - LETTER OF CONSENT FROM CONSORTIUM MEMBERS**

**(On the letter head of each Member of the Consortium including Lead Member)**

Date: .....  
From: .....  
.....  
.....  
Tel. No.: .....  
Fax No.: .....  
E-mail address: .....

To,

**Chief Executive Officer,  
REC Power Development and Consultancy Limited  
(A wholly owned subsidiary of REC Limited)  
REC Corporate Head Quarter,  
D Block, Plot No. I – 4,  
Sec – 29 Gurugram – 122 001**

Dear Sir,

**Sub: Bid for selection of Bidder as Transmission Service Provider to establish Inter-State Transmission System for “Augmentation at Bhadla-III, Ramgarh PS and Kanpur (PG)” through tariff based competitive bidding process.**

We, the undersigned Member of ..... (Insert name of the Bidding Consortium) have read, examined and understood the RFP document for the short-listing of Bidders as prospective TSP to establish Inter-State Transmission System for “**Augmentation at Bhadla-III, Ramgarh PS and Kanpur (PG)**” through tariff based competitive bidding process. We hereby confirm our concurrence with the Bid including in particular the Consortium Agreement submitted by ..... (Insert name of the Lead Member) in response to the RFP document.

We hereby confirm our commitment to participate in the said Bidding Consortium and invest ..... % of the total equity requirement for the Project as per the terms of the Consortium Agreement dated ..... and board resolution for such investment commitment is enclosed herewith.

We hereby confirm that in accordance with Clause 2.1.4 of the RFP, we are enclosing legally binding undertaking supported by a board resolution from the ..... (Insert name of Technically Evaluated Entity and / or Financially Evaluated Entity or its Ultimate Parent Company, as the case may be) that all the equity investment obligations of ..... (Insert name of the Member) shall be deemed to be equity investment obligations of the ..... (Insert name of Technically Evaluated Entity and / or Financially Evaluated Entity or its Ultimate Parent Company, as the case may be) and in the event of any default by..... (Insert name of the Member), the same shall be met by..... (Insert name of Technically Evaluated Entity and / or Financially Evaluated Entity or its Ultimate Parent Company, as the case may be). [Insert if applicable]

**[To be inserted by the Lead Member only]** We are also enclosing legally binding board resolution for the total equity requirement of the Project in case of any breach of any of the equity investment commitment by any of the Consortium Members, in line with the provisions of the Consortium Agreement dated ..... [Bidder to insert date of Consortium Agreement].

The details of contact person are furnished as under:

Name: .....  
Designation: .....  
Name of the Company: .....  
Address: .....  
Phone Nos.: .....  
Fax Nos.: .....  
E-mail address: .....

Dated the ..... day of ..... of 20...

Thanking you,

Yours faithfully,

.....  
**(Signature)**

**Name:** .....  
**Designation:** .....

(Signature, Name, Designation of Authorized Signatory of Consortium Member and Company's Seal)

**ANNEXURE 3 - FORMAT FOR EVIDENCE OF AUTHORIZED SIGNATORY'S  
AUTHORITY (POWER OF ATTORNEY)**

**POWER OF ATTORNEY**

**(To be on non-judicial stamp paper of appropriate value as per Stamp Act relevant to  
place of execution. Foreign companies submitting bids are required to follow the  
applicable law in their country)**

Know all men by these presents, We .....(name and address of the registered office of the Bidder) do hereby constitute, appoint and authorize Mr./Ms.....(name and residential address) who is presently employed with us and holding the position of ..... as our attorney, to do in our name and on our behalf, all such acts, deeds and things necessary in connection with or incidental to our Bid for selection of Bidder as Transmission Service Provider to establish Inter-State Transmission System for **“Augmentation at Bhadla-III, Ramgarh PS and Kanpur (PG)”** through tariff based competitive bidding process in the country of India, including signing and submission of all documents related to the Bid, including, undertakings, letters, certificates, acceptances, clarifications, guarantees, etc., making representations to the BPC, and providing information / responses to the BPC, representing us in all matters before the BPC, and generally dealing with the BPC in all matters in connection with our Bid for the said Project till the completion of the bidding process in accordance with the RFP and signing of the Share Purchase Agreement by all the parties thereto.

We hereby agree to ratify all acts, deeds and things lawfully done by our said attorney pursuant to this Power of Attorney and that all acts, deeds and things done by our aforesaid attorney shall and shall always be deemed to have been done by us.

All the terms used herein but not defined shall have the meaning ascribed to such terms under the RFP.

**For ..... [Insert name of the Bidder on whose behalf PoA is executed]**

.....  
**(Signature)**

Name: .....  
Designation: .....

**Accepted**

.....  
**(Signature of the Attorney)**

Name: .....  
Designation: .....  
Address: .....

.....  
**(Name, Designation and Address of the Attorney)**

Specimen signatures of attorney attested by the Executant

.....  
**(Signature of the Executant)**

.....  
**(Signature of Notary Public)**

Place: .....

Date: .....

**Notes:**

- 1) To be executed by Bidding Company or the Lead Member, in the case of a Bidding Consortium, as the case maybe.
- 2) The mode of execution of the Power of Attorney should be in accordance with the procedure, if any, laid down by the applicable law and the charter documents of the executant(s) and when it is so required, the same should be under common seal of the executant affixed in accordance with the applicable procedure. Further, the person whose signatures are to be provided on the power of attorney shall be duly authorized by the executant(s) in this regard.
- 3) Also, wherever required, the executant(s) should submit for verification the extract of the charter documents and documents such as a Board resolution / power of attorney, in favour of the Person executing this power of attorney for delegation of power hereunder on behalf of the executant(s).
- 4) In case of foreign Bidders, refer to clause 2.5.6 (p)

**ANNEXURE 4 - FORMAT FOR POWER OF ATTORNEY TO BE PROVIDED BY EACH OF THE OTHER MEMBERS OF THE CONSORTIUM IN FAVOUR OF THE LEAD MEMBER**

**POWER OF ATTORNEY**

**(To be on non-judicial stamp paper of appropriate value as per Stamp Act relevant to place of execution. Foreign companies submitting bids are required to follow the applicable law in their country)**

**KNOW ALL MEN BY THESE PRESENTS THAT** M/s....., having its registered office at .....and M/s ..... having its registered office at ..... , (Insert names and registered offices of all Members of the Consortium), the Members of Consortium, have formed a Bidding Consortium named ..... (insert name of the Consortium) (hereinafter called the **“Consortium”**) vide Consortium Agreement dated..... and having agreed to appoint M/s..... as the Lead Member of the said Consortium do hereby constitute, nominate and appoint M/s.....a company incorporated under the laws of .....and having its Registered / Head Office at .....as our duly constituted lawful Attorney (hereinafter called as **“Lead Member”**) which is one of the Members of the Consortium, to act as the Lead Member and our true and lawful attorney, to do in our name and on our behalf, all such acts, deeds and things necessary in connection with or incidental to submission of Consortium's Bid for the Project, including signing and submission of the Bid and all documents related to the Bid, including, undertakings, letters, certificates, acceptances, clarifications, guarantees, etc, making representations to the BPC, and providing information / responses to the BPC, representing us and the Consortium in all matters before the BPC, and generally dealing with the BPC in all matters in connection with our Bid for the said Project, till completion of the bidding process in accordance with the RFP and signing of the Share Purchase Agreement by all the parties thereto.

It is expressly understood that in the event of the Consortium being selected as Successful Bidder, this Power of Attorney shall remain valid, binding and irrevocable until the Bidding Consortium achieves execution of all RFP Project Documents.

We, as the Member of the Consortium, agree and undertake to ratify and confirm all whatsoever the said Attorney/Lead Member has done on behalf of the Consortium Members pursuant to this Power of Attorney and the same shall bind us and deemed to have been done by us.

All the terms used herein but not defined shall have the meaning ascribed to such terms under the RFP.

**IN WITNESS WHEREOF** M/s ..... , as the Member of the Consortium have executed these presents on this..... day of .....

For and on behalf of  
Consortium Member

.....  
**(Signature of the Authorized Signatory)**

Name: .....  
Designation: .....  
Place: .....  
Date: .....

Name: .....  
Designation: .....  
Place: .....  
Date: .....

**Accepted**

Specimen signatures of attorney attested

.....  
**(Signature)**

.....  
.....

**(Signature of Notary Public)**  
.....

**(Name, Designation and Address  
of the Attorney)**

Place: .....  
Date: .....

**Notes:**

1. The mode of execution of the power of attorney should be in accordance with the procedure, if any, laid down by the applicable law and the charter documents of the executant(s) and when it is so required, the same should be under common seal of the executant affixed in accordance with the applicable procedure. Further, the person whose signatures are to be provided on the power of attorney shall be duly authorized by the executant(s) in this regard.
2. Also, wherever required, the executant(s) should submit for verification the extract of the charter documents and documents such as a Board resolution / power of attorney, in favour of the Person executing this power of attorney for delegation of power hereunder on behalf of the executant(s).
3. In case of foreign Bidders, refer to clause 2.5.6 (p)

**ANNEXURE 5 - FORMAT FOR BIDDER'S COMPOSITION AND OWNERSHIP STRUCTURE**

**1. Corporate Details:**

Please provide the following information for the Bidder. If the Bidder is a Consortium, please provide this information for each Member including the Lead Member:

**a. Company's Name, Address, and Nationality:**

Name: .....

Address: .....  
.....  
.....

Website Address: .....

Country of Origin: .....

**b. Year Organized: .....**

**c. Company's Business Activities: .....**  
.....

**d. Status as a Bidder:**

- i. Bidding Company
- ii. Lead Member of the Bidding Consortium
- iii. Member of the Bidding Consortium

**Note: tick the applicable serial number**

**e. Company's Local Address in India (if applicable):**

.....  
.....  
.....

**f. Name of the Authorized Signatory: .....**

**g. Telephone Number: .....**

**h. Email Address: .....**

**i. Telefax Number: .....**

**j. Please provide the following documents:**

- i. Copy of the Memorandum and Articles of Association and certificate of incorporation or other equivalent organizational document (as applicable), including their amendments, certified by the Company Secretary as

**Attachment 1** for Bidding Company / each Member of Bidding Consortium including Lead Member.

- ii. Authority letter (as per format for authorization given below) in favour of BPC from the Bidder/every Member of the Consortium authorizing BPC to seek reference from their respective bankers & others as **Attachment 2** as per Clause 2.1.6 of the RFP.

**2. Details of Ownership Structure:**

Equity holding of Bidding Company/ each Member of Bidding Consortium including Lead Member owning 10% or more of total paid up equity.

Name of the Bidding Company / Consortium Member: .....

Status of equity holding as on .....

Name of the Equity Holder	Type and No. of Shares owned	Extent of Voting Control (%)
1. ....		
2. ....		
3. ....		
4. ....		
5. ....		
6. ....		
7. ....		
8. ....		
....		

**Notes:**

- 1. The above table is to be filled in separately for each Consortium Member.
- 2. Status of equity holding should be provided not earlier than thirty (30) days prior to Bid Deadline.

**For and on behalf of Bidding Company / Lead Member of the Bidding Consortium**

M/s.....

.....

**(Signature of authorized representative)**

Name: .....

Designation: .....

.....

**(Stamp)**

Date: .....

Place: .....

**FORMAT FOR AUTHORISATION**

**(In case of Bidding Consortium, to be given separately by each Member)  
(On Non – judicial stamp paper duly attested by notary public. Foreign companies submitting bids are required to follow the applicable law in their country)**

The undersigned hereby authorize(s) and request(s) all our Bankers, including its subsidiaries and branches, any person, firm, corporation or authority to furnish pertinent information deemed necessary and requested by REC Power Development and Consultancy Limited to verify our Bid for selection of Bidder as Transmission Service Provider to establish Inter-State Transmission system for “**Augmentation at Bhadla-III, Ramgarh PS and Kanpur (PG)**” through tariff based competitive bidding process or regarding our project development experience, financial standing and general reputation.

**For and on behalf of M/s..... (Insert Name of Bidding Company or Member of the Consortium)**

.....  
**(Signature)**

Name of Authorized Signatory: .....

**(Signature and Name of the authorized signatory of the Company)**

Place: .....

Date: .....

.....  
**(Company rubber stamp/seal)**

.....  
**(Signature of Notary Public)**

Place: .....

Date: .....

**ANNEXURE 6 - FORMAT FOR CONSORTIUM AGREEMENT**

**(To be on non-judicial stamp paper of appropriate value as per Stamp Act relevant to place of execution. Foreign companies submitting bids are required to follow the applicable law in their country)**

**THIS CONSORTIUM AGREEMENT** executed on this..... day of .....Two thousand.....between M/s....., a company incorporated under the laws of ..... and having its Registered Office at ..... (hereinafter called the "Party 1", which expression shall include its successors, executors and permitted assigns) and M/s.....a Company incorporated under the laws of ..... and having its Registered Office at ..... (hereinafter called the "Party n", which expression shall include its successors, executors and permitted assigns) and for the purpose of submitting the Bid, acquisition of “..... (Insert the name of SPV)”, (in case of award) and entering into other Agreement(s) as specified in the RFP (hereinafter referred to as “Agreements”) as may be entered into with the Nodal Agency.

**WHEREAS**, the BPC had invited Bid in response to RFP issued to ..... (insert the name of purchaser of RFP) for selection of the bidder as the Transmission Service Provider to establish Inter-State Transmission System for “**Augmentation at Bhadla-III, Ramgarh PS and Kanpur (PG)**”.

**AND WHEREAS**, Clause 2.2.4 of the RFP document stipulates that the Bidders qualifying on the strength of a Bidding Consortium will have to submit a legally enforceable Consortium Agreement in a format specified in the RFP document wherein the Consortium Members have to commit equity of a specific percentage in the Project.

**AND WHEREAS**, Clause 2.2.4 of the RFP document also stipulates that the Bidding Consortium shall provide along with the Bid, a Consortium Agreement as per prescribed format whereby the Consortium Members undertake to be liable for raising the required funds for its respective equity investment commitment as specified in Consortium Agreement.

**NOW THEREFORE, THIS INDENTURE WITNESSTH AS UNDER:**

In consideration of the above premises and agreement all the parties in this Consortium do hereby mutually agree as follows:

1. In consideration of the selection of the Consortium as the selected bidder by the BPC, we the Members of the Consortium and parties to the Consortium Agreement do hereby unequivocally agree that M/s..... (Insert name of the Lead Member), shall act as the Lead Member as defined in the RFP for self and agent for and on behalf of ....., ....., ..... (the names of all the other Members of the Consortium to be filled in here).
2. The Lead Member is hereby authorized by the Members of Consortium and parties to the Consortium Agreement to bind the Consortium and receive instructions for and on behalf of the Members.

3. Notwithstanding anything contrary contained in this Consortium Agreement, the Lead Member shall always be liable for the equity investment obligations of all the Consortium Members, i.e., for both its own equity contribution as well as the equity contribution of other Members.
4. The Lead Member shall be liable and responsible for ensuring the individual and collective commitment of each of the Members of the Consortium in discharging all their respective equity obligations. Each Consortium Member further undertakes to be individually liable for the performance of its part of the obligations without in any way limiting the scope of collective liability envisaged in this agreement.
5. Subject to the terms of this agreement, the share of each Member of the Consortium in the “issued equity share capital of the project company” shall be in the following proportion: (if applicable)

Name	Percentage of equity holding in the Project
Party 1	.....
.....	.....
Party n	.....
<b>Total</b>	<b>100%</b>

[Note: The percentage equity holding for any Consortium Member in the Project cannot be zero in the above table]

6. The Lead Member shall inter alia undertake full responsibility for liaising with lenders and mobilizing debt resources for the Project and achieving financial closure.
7. In case of any breach of any of the equity investment commitment by any of the Consortium Members, the Lead Member shall be liable for the consequences thereof.
8. Except as specified in the Agreement, it is agreed that sharing of responsibilities as aforesaid and equity investment obligations thereto shall not in any way be a limitation of responsibility of the Lead Member under these presents.
9. It is further specifically agreed that the financial liability for equity contribution of Lead Member shall, not be limited in any way so as to restrict or limit its liabilities. The Lead Member shall be liable irrespective of their scope of work or financial commitments.
10. It is expressly understood and agreed between the Members that the responsibilities and obligations of each of the Members shall be as delineated as annexed hereto as **Appendix-I**, forming integral part of this Agreement. It is further agreed by the Members that the above sharing of responsibilities and obligations shall not in any way be a limitation of joint and several responsibilities and liabilities of the Members, with regards to all matters relating to the Project.
11. It is clearly agreed that the Lead Member shall ensure performance under the Agreements and if one or more Consortium Members fail to perform its /their respective obligations under the Agreement(s), the same shall be deemed to be a default by all the Consortium Members.

12. This Consortium Agreement shall be construed and interpreted in accordance with the Laws of India and courts at **Delhi** alone shall have the exclusive jurisdiction in all matters relating thereto and arising there under.
13. It is hereby agreed that, the Lead Member shall furnish the bid bond, as stipulated in the RFP, on behalf of the Consortium Members.
14. It is hereby agreed that in case of selection of Bidding Consortium as the selected bidder, the parties to this Consortium Agreement do hereby agree that they shall furnish the contract performance guarantee on behalf of the TSP in favor of the Nodal Agency, as stipulated in the RFP and Transmission Service Agreement.
15. It is further expressly agreed that the Consortium Agreement shall be irrevocable and shall form an integral part of the RFP Project Document and shall remain valid till the execution of the Share Purchase Agreement, unless expressly agreed to the contrary by the Nodal Agency. Over the term of the Transmission Service Agreement, Central Electricity Regulatory Commission (Sharing of Inter-State Transmission Charges and Losses) Regulations as amended from time to time shall apply on the Consortium Members.
16. The Lead Member is authorized and shall be fully responsible for the accuracy and veracity of the representations and information submitted by the Consortium Members respectively from time to time in response to the RFP and for the purposes of the Project.
17. It is hereby expressly agreed between the parties to this Consortium Agreement that neither party shall assign or delegate its rights, duties or obligations under this Agreement except with the prior written consent of the Nodal Agency.

**THIS CONSORTIUM AGREEMENT:**

- a. has been duly executed and delivered on behalf of each party hereto and constitutes the legal, valid, binding and enforceable obligation of each such party,
- b. sets forth the entire understanding of the parties hereto with respect to the subject matter hereof;
- c. may not be amended or modified except in writing signed by each of the parties and with prior written consent of the Nodal Agency.

**IN WITNESS WHEREOF**, the parties to the Consortium Agreement have, through their authorized representatives, executed these present on the Day, Month and Year first mentioned above.

For and on behalf of Consortium Member 1 (Party 1)  
M/s.....

.....  
**(Signature of authorized signatory)**

Name: .....  
Designation: .....  
Place: .....  
Date: .....

For and on behalf of Consortium Member n (Party n)  
M/s.....

.....  
**(Signature of authorized signatory)**

Name: .....  
Designation: .....  
Place: .....  
Date: .....

**Attested:**

.....  
**(Signature)**  
**(Notary Public)**

Place: .....  
Date: .....

Note: In case of foreign Bidders, refer to clause 2.5.6 (p)

**Appendix 1 to the Consortium Agreement:**

<b>Name of the Consortium Member</b>	<b>Responsibilities under the Consortium Agreement</b>
M/s ..... (Party 1)	
M/s .....	
M/s ..... (Party n)	

**ANNEXURE 7A - FORMAT FOR QUALIFICATION REQUIREMENT**

**A. NET WORTH**

To,  
**Chief Executive Officer,**  
**REC Power Development and Consultancy Limited**  
**(A wholly owned subsidiary of REC Limited)**  
**REC Corporate Head Quarter,**  
**D Block, Plot No. I – 4,**  
**Sec – 29 Gurugram – 122 001**

Dear Sir,

**Sub: Bid for selection of Bidder as Transmission Service Provider to establish Inter-State Transmission System for “Augmentation at Bhadla-III, Ramgarh PS and Kanpur (PG)” through tariff based competitive bidding process**

**1. [Note: Applicable in case of Bidding Company]**

We certify that the Financially Evaluated Entity(ies) had a Networth of Rs. .... Crore or equivalent USD\* computed as per instructions in this RFP based on unconsolidated audited annual accounts (refer Note-2 below) of any of the last three (3) financial years as provided in Clause 2.2.3, immediately preceding the Bid Deadline. Also, the Networth of any of the last three (3) financial years is not negative.

<b>Name of Financially Evaluated Entity(ies)</b>	<b>Relationship with Bidding Company**</b>	<b>Financial Year</b>	<b>Networth (Rs. Crore)</b>
1. ....			
2. ....			
3. ....			
....			
<b>Total Networth</b>			

\*Equivalent USD shall be calculated as per provisions of Clause 3.4.1.

\*\* The column for “Relationship with Bidding Company” is to be filled in only in case financial capability of Parent/Affiliate has been used for meeting Qualification Requirements.

**2. [Note: Applicable in case of Bidding Consortium]**

We certify that the Financially Evaluated Entity(ies) had a minimum Networth of Rs. .... Crore or equivalent USD\* computed as per instructions in the RFP and based on unconsolidated audited annual accounts (refer Note-2 below) of any of the last three (3) financial years as provided in Clause 2.2.3, immediately preceding the Bid Deadline. Also, the Networth of any of the last three (3) financial years is not negative.

Name of Consortium Member	Equity Commitment in the Project (%)	Networth of Member (Rs. Crore)	Networth Requirement to be met by Member in proportion to the Equity Commitment (Rs. Crore)	Whether the Member meets the Networth Requirement
(1)	(2)	(3) (As per table below)	(4) = (2 x Total Networth requirement for the Project)	(5)
1. ....				Yes / No
2. ....				Yes / No
..				Yes / No
<b>Total Networth for financial requirement</b>				

**Member – I (Lead Member)**

[Note: Similar particulars for each Member of the Consortium is to be furnished, duly certified by the Member's Statutory Auditors]

- i. Name of Member: .....
- ii. Total Networth requirement: Rs ..... Crore
- iii. Percentage of equity commitment for the Project by the Member: .....%
- iv. Networth requirement for the Member\*\*\*: Rs ..... Crore
- v. Financial year considered for the Member: .....

Name of Financially Evaluated Entity(ies)	Relationship** with Member of Consortium	Financial Year	Networth (Rs. Crore)
1. ....			
2. ....			
3. ....			
<b>Total Networth</b>			

\* Equivalent USD shall be calculated as per provisions of Clause 3.4.1;

\*\* The column for "Relationship with Member of Consortium" is to be filled in only in case the financial capability of Parent / Affiliate has been used for meeting Qualification Requirements;

\*\*\* Networth requirement to be met by Member should be in proportion to the equity commitment of the Member for the Project.

**Yours faithfully**

.....  
**(Signature and name of the authorized signatory of the Company and Stamp)**

Name: .....  
Date: .....  
Place: .....

.....  
**(Signature and Stamp of statutory Auditors of Bidding Company / each Member of Consortium)**

Name: .....  
Date: .....  
Place: .....

Date: .....

**Notes:**

1. Along with the above format, in a separate sheet, please provide details of computation of Networth of last three (3) financial years duly certified by Statutory Auditor.
2. Audited consolidated annual accounts of the Bidder may be used for the purpose of financial criteria provided the Bidder has at least 26% equity in each company whose accounts are merged in the audited consolidated accounts and provided further that the financial capability of such companies (of which accounts are being merged in the consolidated accounts) shall not be considered again for the purpose of evaluation of the Bid.
3. In case Bidder or a Member of Consortium takes recourse to its Parent/Affiliate for meeting technical / financial requirements, then the financial years considered for such purpose should be same for the Bidder / Member of Consortium and their respective Parent / Affiliate.

**ANNEXURE 7B - FORMAT FOR TECHNICAL REQUIREMENT**

To,

**Chief Executive Officer,  
REC Power Development and Consultancy Limited  
(A wholly owned subsidiary of REC Limited)  
REC Corporate Head Quarter,  
D Block, Plot No. I – 4,  
Sec – 29 Gurugram – 122 001**

Dear Sir,

**Sub: Bid for selection of Bidder as Transmission Service Provider to establish Inter-State Transmission system for “Augmentation at Bhadla-III, Ramgarh PS and Kanpur (PG)” through tariff based competitive bidding process.**

**1. To be used by Bidder using the development experience in infrastructure sector**

We certify that M/s. .... (Insert name of Technically Evaluated Entity(ies)) have experience of development of projects in the Infrastructure sector in the last five (5) years whose aggregate capital expenditure is Rs. .... Crore or equivalent USD\*. We further certify that the capital expenditure of any single project considered for meeting the technical Qualification Requirement is not less than Rs. .... Crore or equivalent USD\*. For this purpose, capital expenditure incurred on projects which have been either wholly completed / commissioned or partly completed projects put under commercial operation and for which operation has commenced till at least seven (7) days prior to the Bid Deadline has been considered.

The project(s) considered for the purpose of technical experience (as per table given below) have been executed and owned to the extent as indicated in the table below (to be atleast twenty – six percent (26%)) by the Bidding Company / Lead Member of the Consortium / our Parent / our Affiliate(s) [strike off whichever is not applicable] on operation of the projects.

This technical requirement has been calculated as per the instructions provided in the RFP on the basis of following projects:

Name of Company (which has executed the project at (3)) whose technical capability has been used for Qualification Requirement	Relationship** with Bidding Company / Lead Member	Project name	Nature of Project (BOO T, BOT, BOO M, DBFO T etc.)	Relevant Infrastructure sector	Date of Financial Closure of the Project (in DD / MM / YYYY )	Date of Completion / Commissioning / Commercial Operation of partly completed projects	Project cost (Rs. Crore )	Percentage Equity Holding of Company at (1) in Completed project(s)
(1)	(2)	(3)	(4)	(5)	(6)	(7)	(8)	(9)
.....		..... .... (Project 1)						
.....		..... ....						
<b>Total (Rs. Crore)</b>								

\* Equivalent USD shall be calculated as per provisions of Clause \_\_\_\_\_

\*\* The column for “Relationship with Bidding Company / Lead Member” is to be filled in only in case technical capability of Parent/Affiliate has been used for meeting Qualification Requirements.

We further certify that the Company(ies) as indicated in column (1) of the above table, whose technical capability has / have been used for meeting the qualification requirement, has / have held shareholding respectively of atleast twenty – six percent (26%) from the date of financial closure till the date of commissioning / completion of the above project(s).

## 2. To be used by Bidder using construction experience in infrastructure sector.

We certify that M/s. .... (Insert name of Technically Evaluated Entity(ies)) have received aggregate payments not less than Rs. .... Crore or equivalent USD (calculated as per provisions in Clause 3.4.1) from its client(s) for construction works fully completed during the last 5(five) financial years. We further certify that the payment received from each project shall not be less than Rs. .... Crore or equivalent USD (calculated as per provisions in Clause 3.4.1). For this purpose, payments received on projects that have been commissioned/completed at least seven (7) days prior to the Bid Deadline shall be considered. Further only the payments (gross) actually received, during such 5 (five) financial years shall qualify for purposes of computing the technical capacity.

We also confirm that construction works does not include cost of land supply of goods or equipment except when such goods or equipment form part of a turn-key construction contract/ EPC contract for the project.

This technical requirement has been calculated as per the instructions provided in the RFP on the basis of following projects:

Name of Company (which has executed the project at (3)) whose technical capability has been used for Qualification Requirement	Relationship ** with Bidding Company / Lead Member	Project name	Nature of Project (EPC, Turnkey etc)	Relevant Infrastructure sector	Date of award of contract (in dd/mm/y)	Date of Completion / Commissioning	Payment received (Rs. Crore)
(1)	(2)	(3)	(4)	(5)	(6)	(7)	(8)
..... ...		..... . Project 1					
..... ...		..... .					
..... ...		..... .					
Total (Rs. Crore)							

Yours faithfully

.....  
**(Signature and name of the authorized signatory of the Company and stamp)**

Name: .....  
Date: .....  
Place: .....

.....  
**(Signature and Stamp of statutory Auditors of Bidding Company/ Lead Member of Consortium)**

Name: .....  
Date: .....  
Place: .....

Date: .....

**Notes:**

1. Along with the above format, in a separate sheet, please provide details of computation of capital expenditure of projects duly certified by Statutory Auditor of the project company. In addition, the Statutory Auditor of the project company should also certify that the capital expenditure of projects commissioned or completed 7 days prior to Bid Deadline has been capitalized in the books of accounts.

Additionally, in case construction experience is used, a certificate(s) from the statutory auditors stating the payments received and the concerned client(s) stating the works commissioned during the past 5 years in respect of the projects specified above. In case a particular job/ contract has been jointly executed by the Bidder (as part of a consortium), it should further support its claim for the share in work done for that particular job/ contract by producing a certificate from its statutory auditor or the client.

2. In case the accounts for the financial year in which the project claimed for meeting qualification requirement has been commissioned are not audited, the Bidder shall give declaration in this regard duly certified by its statutory auditor. In such a case, Bidder shall provide details of computation of capital expenditure of such project(s) duly certified by Statutory Auditor of the project company and the Statutory Auditor of the project company should also certify that the capital expenditure of projects commissioned or completed shall be capitalized in the books of accounts upon finalization.
3. The unconsolidated audited annual accounts of both the TEE and the Bidding Company / Lead Member for the respective financial years (financial years in which financial closure was achieved to the financial year in which the said project was completed / commissioned) should be submitted.

**ANNEXURE 7C - FORMAT FOR TECHNICAL & FINANCIAL REQUIREMENT –  
RELATIONSHIP & DETAILS OF EQUITY SHAREHOLDING**

[To be filled by Bidding Company / each Member of the Bidding Consortium including Lead Member if credentials of Parent and / or Affiliates have been used by them]

To,

**Chief Executive Officer,  
REC Power Development and Consultancy Limited  
(A wholly owned subsidiary of REC Limited)  
REC Corporate Head Quarter,  
D Block, Plot No. I – 4,  
Sec – 29 Gurugram – 122 001**

Dear Sir,

**Sub: Bid for selection of Bidder as Transmission Service Provider to establish Inter-State Transmission system for “Augmentation at Bhadla-III, Ramgarh PS and Kanpur (PG)” through tariff based competitive bidding process**

We certify that M/s. .... (insert name of the **Bidding Company / Consortium Members**) have considered the technical and financial capability of its Parent and / or Affiliates, for the purpose of meeting Qualification Requirements as per the instructions provided in the RFP. The name of Parent and / or Affiliate, nature of relationship(s) with such Parent and / or Affiliate and details of equity holding are as follows:

<b>Name of Company whose credentials considered</b>	<b>Type of credentials considered (technical and / or financial)</b>	<b>Relationship with Bidding Company / Consortium Member (Parent / Affiliate)</b>	<b>Details of equity shareholding (refer notes below)</b>
Company 1			
.....			
.....			
.....			
.....			

**NOTES:**

- i. In case of Parent, the equity holding of the Parent in the Bidding Company / Member of the Bidding Consortium, including the Lead Member of the Consortium, need to be specified.
- ii. In case of Affiliate under direct control of Bidder, the equity holding of the Bidding Company / Member of the Bidding Consortium, including the Lead Member of the Consortium in the Affiliate, needs to be specified.
- iii. In case of Affiliate under common control of Parent, the equity holding of the Parent in the Affiliate of the Bidding Company / Member of the Bidding Consortium, including the Lead Member of the Consortium, needs to be specified.

- iv. Relationship of Parent / Affiliate with Bidding Company / Member of Consortium to be at the most seven (7) days prior to the Bid Deadline (as per Clause 2.1.4 of RFP)

Yours faithfully

.....  
**(Signature and name of the authorized signatory of the Company and stamp)**

Name: .....  
Date: .....  
Place: .....

.....  
**(Signature and Stamp of statutory Auditors of Bidding Company / each Member of Bidding Consortium)**

Name: .....  
Date: .....  
Place: .....

**ANNEXURE 7D - ADDITIONAL INFORMATION FOR VERIFICATION OF FINANCIAL AND TECHNICAL CAPABILITIES OF BIDDERS.**

<p>.....</p> <p><b>(Name of Bidder (Bidding Company/ Bidding Consortium or Technically/Financially Evaluated Entity(ies)))</b></p> <p><b>(Note: In case of Consortium, details to be filled in by Lead Member for each Member of the Consortium including the Lead Member and in case of the qualification requirements of Technically / Financially Evaluated Entity(ies) being used, to be filled by each of such entity(ies))</b></p>
--

**i. Financial capability (Attachment 1):**

1. Bidders shall attach unconsolidated / consolidated audited annual accounts, statements, as the case may be, (refer Clause 2.1.3) for the last three (3) financial years as Attachment 1. Such unconsolidated audited annual accounts shall include a Balance Sheet, Profit and Loss Account, Auditors Report and profit appropriation account.

**ii. Technical capability (Attachment 2):**

- a. This attachment shall include details of projects completed/commissioned or partly completed projects for which commercial operation has commenced to be considered for the purpose of meeting Qualification Requirements.

1. To be used by Bidder using development experience in infrastructure sector

Particulars	Year 1	Year 2	Year 3	Year 4	Year 5
Name(s) of project(s) from Infrastructure sectors					
Location(s) including country(s) where project was set up					
Nature of Project					
Voltage level (if any)					
Capital cost of project(s) Rs. in Crore					
*Status of the project					
% of equity owned in the project(s)					

**\*Note 1:** Date of completion/commissioning/commercial operation to be mentioned

**Note 2:** For each project listed in the table, the Bidder shall furnish an executive summary including the following information:

- Project model, i.e., BOO, BOOT, BOOM;

- Debt financing and equity raised and provided by Bidder/Bidder's Parent/Bidder's Affiliate for the project, including names of lenders and investors;
- Size and type of installation;
- Technical data/information on major equipment installed
- Description of role performed by the Bidder/Bidder's Parent/Bidder's Affiliate on the project
- Clearances taken by the Bidder/Bidder's Parent/Bidder's Affiliate including but limited to right-of-way (RoW), forest clearance and other statutory / Govt. clearances.
- Cost data (breakdown of major components)
- Name of EPC and/or other major contractor
- Construction time for the project
- Names, addresses and contact numbers of owners of the projects
- Operating reliability over the past five (5) years or since date of commercial operation
- Operating environmental compliance history
- Names of supervisory entities or consultant, if any
- Date of commercial operation
- Total duration of operation

2. To be used by Bidder using construction experience in infrastructure sector

Particulars	Year 1	Year 2	Year 3	Year 4	Year 5
Name(s) of project(s) from Infrastructure sectors					
Location(s) including country(s) where project was set up					
Nature of Project					
Voltage level (if any)					
Revenue received Rs. in Crore					
*Status of the project					
% of equity owned in the project(s)					

**\*Note 1:** Date of completion/commissioning/commercial operation to be mentioned

**Note 2:** For each project listed in the table, the Bidder shall furnish an executive summary including the following information:

- Project model, i.e., EPC, Turnkey;
- Size and type of installation;
- Technical data/information on major equipment installed
- Description of role performed by the Bidder/Bidder's Parent/Bidder's Affiliate on the project
- Cost data (breakdown of major components)
- Name of sub-contractor
- Construction time for the project
- Names, addresses and contact numbers of owners of the projects
- Operating reliability over the past five (5) years or since date of commercial operation
- Operating environmental compliance history

- Names of supervisory entities or consultant, if any
- Date of commercial operation
- Total duration of operation

**iii. Attachment-3:**

- a. For each project listed in Attachment 2 above, certificates of final acceptance and/or certificates of good operating performance duly issued by owners for the project and the same shall be certified as true by authorized signatory of the Bidding Company or the Lead Member of Consortium). In case the project listed in Attachment 2 is under BOOT / DBFOT mechanism, the certificates of final acceptance and/or certificates of good operating performance must be issued by the authority / independent engineer of the project as defined in the respective project agreement.

For and on behalf of Bidding Company/Consortium

M/s.....

.....  
**(Signature of authorized signatory)**

Name: .....  
Designation: .....  
Date: .....  
Place: .....

**ANNEXURE 8 -UNDERTAKING AND DETAILS OF EQUITY INVESTMENT**

**Format 1: Bidders' Undertakings**

**[On the Letter Head of the Bidding Company/Lead Member of Bidding Consortium]**

**Date:** .....

**To,**

**Chief Executive Officer,  
REC Power Development and Consultancy Limited  
(A wholly owned subsidiary of REC Limited)  
REC Corporate Head Quarter,  
D Block, Plot No. I – 4,  
Sec – 29 Gurugram – 122 001**

Dear Sir,

**Sub: Bidders' Undertakings in respect of Bid for selection of Bidder as TSP to establish Inter-State transmission system for “Augmentation at Bhadla-III, Ramgarh PS and Kanpur (PG)”**

We hereby undertake on our own behalf and on behalf of the TSP, that if selected as the Successful Bidder for the Project:

1. The Project shall comply with all the relevant electricity laws, codes, regulations, standards and Prudent Utility Practices, environment laws and relevant technical, operational and safety standards, and we shall execute any agreements that may be required to be executed as per law in this regard.
2. We confirm that the Project shall also comply with the standards and codes as per Clause 1.6.1.2 of the RFP and the TSP shall comply with the provisions contained in the Central Electricity Regulatory Commission Grant of Connectivity, Long-term Access and Medium-term Open Access in inter-state Transmission and related matters Open Access) Regulations, 2009.
3. We give our unconditional acceptance to the RFP dated 25.03.2026 issued by the BPC and the RFP Project Documents, as amended, and undertake to ensure that the TSP shall execute all the RFP Project Documents, as per the provisions of this RFP.
4. We have submitted the Bid on the terms and conditions contained in the RFP and the RFP Project Documents. Further, the Financial Bid submitted by us is strictly as per the format provided in Annexure 21 of the RFP, without mentioning any deviations, conditions, assumptions or notes in the said Annexure.
5. Our Bid is valid up to the period required under Clause 2.8 of the RFP.
6. Our Bid has been duly signed by authorized signatory and stamped in the manner and to the extent indicated in this RFP and the power of attorney / Board resolution in requisite format as per RFP has been enclosed with this undertaking.

7. We have assumed that if we are selected as the Successful Bidder, the provisions of the Consortium Agreement, to the extent and only in relation to equity lock in and our liability thereof shall get modified to give effect to the provisions of Clause 2.5.8 of this RFP and Article 18.1 of the Transmission Service Agreement. *(Note: This is applicable only in case of a Bidding Consortium)*
8. We confirm that our Bid meets the Scheduled COD of each transmission Element and the Project as specified below:

Sl. No.	Name of the Transmission Element	Scheduled COD*	Percentage of Quoted Transmission Charges recoverable on Scheduled COD of the Element of the Project**	Element(s) which are pre-required for declaring the commercial operation (COD) of the respective element
1.	Augmentation of 400/220 kV, 5x500 MVA (6 <sup>th</sup> to 10 <sup>th</sup> ) ICTs at 765/400/220 kV Bhadla-III PS	20.01.2029 (matching with timeframe of Transmission System for Evacuation of Power from REZ in Rajasthan (20 GW) under Phase III – Part I scheme (Pole 1))	36.4%	These elements of the scheme are required to be commissioned simultaneously as their utilization is dependent on each other.
2.	Implementation of 5 Nos. of 220 kV line bays at 765/400/220 kV Bhadla-III PS.			
3.	Implementation of 1 No. of 400 kV line bay at 765/400/220 kV Bhadla-III PS.			
4.	Implementation of 2 sets 400 kV sectionlizer bay at 765/400/220 kV Bhadla-III PS			
5.	Augmentation of 765/400 kV, 2x1500 MVA (3 <sup>rd</sup> & 4 <sup>th</sup> ) ICTs at 765/400/220 kV Ramgarh PS		39.6%	These elements of the scheme are required to be commissioned simultaneously as their utilization is dependent on each other.
6.	Augmentation of 400/220 kV, 2x500 MVA (3 <sup>rd</sup> & 4 <sup>th</sup> ) ICTs at 765/400/220 kV Ramgarh PS			

Sl. No.	Name of the Transmission Element	Scheduled COD*	Percentage of Quoted Transmission Charges recoverable on Scheduled COD of the Element of the Project**	Element(s) which are pre-required for declaring the commercial operation (COD) of the respective element
7.	Implementation of 2 Nos. of 220 kV line bays at 765/400/220 kV Ramgarh PS			
8.	Implementation of 1 No. of 400 kV line bay at 765/400/220 kV Ramgarh PS			
9.	Augmentation of 765/400 kV, 1x1500 MVA (3 <sup>rd</sup> ) ICT at 765/400 kV Kanpur (PG) substation		24%	Utilization of this Element is independent

We agree that the payment of Transmission Charges for any Element irrespective of its successful commissioning on or before its Scheduled COD shall only be considered after the successful commissioning of Element(s) which are pre-required for declaring the commercial operation of such Element as mentioned in the above table.

**Scheduled COD for the Project:** 20.01.2029 (matching with timeframe of Transmission System for Evacuation of Power from REZ in Rajasthan (20 GW) under Phase III-Part I scheme (Pole 1)).

9. We confirm that our Financial Bid conforms to all the conditions mentioned in this RFP, and in particular, we confirm that:
  - a. Financial Bid in the prescribed format of Annexure 21 has been submitted duly signed by the authorized signatory.
  - b. Financial Bid is unconditional.
  - c. Only one Financial Bid has been submitted.
  
10. We have neither made any statement nor provided any information in this Bid, which to the best of our knowledge is materially inaccurate or misleading. Further, all the confirmations, declarations and representations made in our Bid are true and accurate. In case this is found to be incorrect after our acquisition of “..... (Insert the name of SPV)”, pursuant to our selection as Selected Bidder, we agree that the same would be treated as a TSP's Event of Default under Transmission Service Agreement, and relevant provisions of Transmission Service Agreement shall apply.

11. We confirm that there are no litigations or other disputes against us which materially affect our ability to fulfill our obligations with regard to the Project as per the terms of RFP Project Documents.
12. Power of attorney/ Board resolution as per Clause 2.5.2 is enclosed.

**Signature and name of the authorized signatory of the Company and stamp of Bidding Company or Lead member of Consortium**

**Note:**

1. In case of foreign Bidders, refer to clause 2.5.6 (p)

**Format 2: Details of equity investment in Project**

1.1.a Name of the Bidding Company/ Bidding Consortium:

1.1.b Name of the Lead Member in the case of a Bidding Consortium:

1.2 Investment details of the Bidding Company/Member of the Bidding Consortium investing in ..... (Insert the name of SPV), as per Clause 2.5.8.2.

S. No.	Name of the Bidding Company/ Member in case of a Bidding Consortium	Name of the Company investing in the equity of the ..... (Insert the name of SPV)	Relationship with Bidding Company /Member of the Bidding Consortium	% of equity participation in the ..... (Insert the name of SPV)
(1)	(2)	(3)	(4)	(5)
TOTAL				100%

\* In case the Bidder proposes to invest through its Affiliate(s) / Parent Company / Ultimate Parent Company, the Bidder shall declare shareholding pattern of such Affiliate(s) / Parent Company / Ultimate Parent Company and provide documentary evidence to demonstrate relationship between the Bidder and the Affiliate(s) / Parent Company / Ultimate Parent Company. These documentary evidences could be, but not limited to, demat account statement(s) / Registrar of Companies' (ROC) certification / share registry book, etc duly certified by Company Secretary.

Members of the Consortium or the Bidding Company making investment in the equity of the ..... (Insert the name of SPV) themselves to fill in their own names in the column (3)

**Signature and Name of authorized signatory in whose name power of attorney has been issued**

Signature of authorized signatory

Name: .....

Designation: .....

Date.....

Company rubber stamp

**ANNEXURE 9 -AUTHORISATION FROM PARENT / AFFILIATE OF BIDDING COMPANY / MEMBER OF BIDDING CONSORTIUM WHOSE TECHNICAL / FINANCIAL CAPABILITY HAS BEEN USED BY THE BIDDING COMPANY / MEMBER OF BIDDING CONSORTIUM.**

**[On the Letter Head of the Parent /Affiliate]**

Name: .....  
Full Address: .....  
Telephone No.: .....  
E-mail address: .....  
Fax / No.: .....

**To**

**Chief Executive Officer,  
REC Power Development and Consultancy Limited  
(A wholly owned subsidiary of REC Limited)  
REC Corporate Head Quarter,  
D Block, Plot No. I – 4,  
Sec – 29 Gurugram – 122 001**

Dear Sir,

**Sub: Authorization for use of Technical / Financial Capability of M/s.....  
(Insert name of Parent / Affiliate) by M/s ..... (Insert name of Bidding  
Company / Member of Bidding Consortium).**

We refer to the RFP dated 25.03.2026 ('RFP') issued by you for selection of Bidder as Transmission Service Provider for establishing the Inter-State Transmission System for **“Augmentation at Bhadla-III, Ramgarh PS and Kanpur (PG)”**.

We confirm that M/s. .... (Insert name of Bidding Company/ Consortium Member) has been authorized by us to use our technical and/or financial capability [strikeout whichever is not applicable] for meeting the Qualification Requirements for **“Augmentation at Bhadla-III, Ramgarh PS and Kanpur (PG)”**.

We have carefully read and examined in detail the RFP including in particular, Clause 2.1.4 of the RFP, and we are also submitting legally binding undertaking supported by a board resolution that all the equity investment obligations of M/s..... (Insert Name of Bidding Company / Consortium Member), shall be deemed to be our equity investment obligations and in the event of any default the same shall be met by us. For and on behalf of M/s..... (Insert Name of Parent / Affiliate)

.....  
**(Signature and Name of the authorized signatory of the Company and stamp)**

Name: .....

Date: .....

Place: .....

**Notes:**

1. The above undertaking can be furnished by Ultimate Parent of Technically Evaluated Entity or Financially Evaluated Entity, as the case maybe, if legally binding undertaking is also furnished by the Ultimate Parent on behalf of such Financially Evaluated Entity/Technically Evaluated Entity.

**ANNEXURE 10- FORMAT OF UNDERTAKING BY TECHNICALLY / FINANCIALLY  
EVALUATED ENTITY / ULTIMATE PARENT COMPANY**

**[On the Letter Head of the Technically / Financially Evaluated Entity / Ultimate Parent  
Company]**

Name: .....

Full Address: .....

Telephone No.: .....

E-mail address: .....

Fax/No.: .....

**To:**

**Chief Executive Officer,  
REC Power Development and Consultancy Limited  
(A wholly owned subsidiary of REC Limited)  
REC Corporate Head Quarter,  
D Block, Plot No. I – 4,  
Sec – 29 Gurugram – 122 001**

**Sub:        Undertaking for equity investment**

Dear Sir,

We refer to the Request for Proposal dated ..... ('RFP') issued by you regarding setting up of Inter-State transmission system for “**Augmentation at Bhadla-III, Ramgarh PS and Kanpur (PG)**” Project on build, own, operate and transfer basis.

We have carefully read and examined in detail the RFP and the RFP Project Documents, including in particular, Clause 2.1.4 of the RFP and Clauses 2.5.2 and 2.5.8 of the RFP, regarding submission of an undertaking regarding the investment in the equity share capital of ..... (Insert the name of SPV), and provisions for minimum equity holding and equity lock-in. We have also noted the amount of the equity investment required to be made in ..... (Insert the name of SPV), by the ..... [Insert the name of the Bidder or the Consortium Member] for the Project.

In view of the above, we hereby undertake to you and confirm that in the event of failure of ..... [Insert the name of the Bidder or the Consortium Member] to invest in full or in part, in the equity share capital of ..... (Insert the name of SPV), as specified in the Bid, we shall invest the said amount not invested by.....[Insert the name of the Bidder or the Consortium Member] in ..... (Insert the name of SPV), by purchase of existing shares or subscribing to the new shares of ..... (Insert the name of SPV), as stipulated by you.

We have attached hereto certified true copy of the Board resolution whereby the Board of Directors of our Company has approved issue of this Undertaking by the Company.

All the terms used herein but not defined, shall have the meaning as ascribed to the said terms under the RFP.

Certified as true.

.....

**(Signature and Name of the authorized signatory of the Company and stamp)**

**Note:**

1. Wherever required, extract of the charter documents and documents such as a Board resolution should be submitted for verification.

**ANNEXURE 11 - FORMATS FOR BOARD RESOLUTIONS**

**Format 1**

**Format of the Board resolution for the Bidding Company / each Member of the Consortium / investing Affiliate / Parent Company / Ultimate Parent Company, where applicable**

[Reference Clause 2.5.2 of the RFP and the illustrations in Annexure 11A]

[**Note:** The following resolution no.1 needs to be passed by the Boards of each of the entity/(ies) making equity investment]

The Board, after discussion, at the duly convened Meeting on ..... [Insert date], with the consent of all the Directors present and in compliance of the provisions of the Companies Act, 1956/2013, passed the following Resolution:

**1. RESOLVED THAT** pursuant to the provisions of the Companies Act, 1956 / Companies Act 2013 (as the case may be) and compliance thereof and as permitted under the Memorandum and Articles of Association of the company, approval of the Board be and is hereby accorded for investment of.....% (.....per cent) of the total equity share capital of ..... (Insert the name of SPV), representing the entire amount proposed to be invested by the company for the transmission system for “**Augmentation at Bhadla-III, Ramgarh PS and Kanpur (PG)**”, partly by acquisition of the existing equity shares from .....[Insert the name of the BPC] and / or partly by subscribing to the new equity shares, as per the terms of the RFP.

[**Note:** Equity investment obligations by the Bidding Company/each Member of the Bidding Consortium/investing Affiliate or Parent or Ultimate Parent should add up to 100%.]

[**Note:** In the event the Bidder is a Bidding Consortium, the following Board resolution no. 2 also needs to be passed by the Lead Member of the Bidding Consortium]

**2. RESOLVED THAT** approval of the Board be and is hereby accorded to contribute such further amount over and above the ..... percentage (\_\_\_%) limit to the extent becoming necessary towards the total equity share in the ..... (Insert the name of SPV), obligatory on the part of the company pursuant to the terms and conditions contained in the Consortium Agreement dated ..... executed by the company as per the provisions of the RFP.

[**Note:** In the event, the investing entity is an Affiliate or Parent or Ultimate Parent of the Bidder, the following Board resolution no. 3 shall also be passed by the Bidder]

**3. FURTHER RESOLVED THAT** the Board hereby acknowledges the Board Resolution(s) passed by the..... [Name of the Affiliate(s)/ Parent / Ultimate Parent] regarding the investment of.....(....%) of the equity share capital requirements of ..... (Insert the name of SPV), which is to be invested by the .....[Name of the Affiliate(s)/ Parent / Ultimate Parent] for the ..... (Insert the name of SPV), partly by acquisition of the existing equity shares from \_\_\_\_\_[Name of BPC] and partly by subscribing to the new equity shares, as per the terms of the RFP.

[**Note:** The following resolution no. 4 is to be provided by the Bidding Company / Lead Member of the Consortium only]

4. FURTHER RESOLVED THAT MR/MS .....be and is hereby authorized to take all the steps required to be taken by the Company for submission of the Bid, including in particular, signing of the Bid, making changes thereto and submitting amended Bid, all the documents related to the Bid, certified copy of this Board resolution or letter or undertakings etc, required to be submitted to BPC as part of the Bid or such other documents as may be necessary in this regard.

Certified True Copy

Company rubber stamp to be affixed

**[Notes:**

- 1) This certified true copy should be submitted on the letterhead of the Company, signed by the Company Secretary or any Whole Time Director/ Manager (supported by a specific board resolution) of the Bidding Company or the Lead Member of Consortium.
- 2) The contents of the format may be suitably re-worded indicating the identity of the entity passing the resolution, i.e., the Bidding Company, each Member of the Bidding Consortium.
- 3) This format may be modified only to the limited extent required to comply with the local regulations and laws applicable to a foreign entity submitting this resolution. For example, reference to Companies Act 1956 / Companies Act 2013 (as the case may be) may be suitably modified to refer to the law applicable to the entity submitting the resolution. However, in such case, the foreign entity shall submit an unqualified opinion issued by the legal counsel of such foreign entity, stating that the Board resolutions are in compliance with the applicable laws of the respective jurisdictions of the issuing company and the authorizations granted therein are true and valid.]

**Format 2**

**Format for the Board resolution of Technically / Financially Evaluated Entity / Ultimate Parent Company (in case credentials of such TEE/ FEE has been utilized by the Bidding Company or Bidding Consortium)**

The Board, after discussion, at the duly convened Meeting on ..... [Insert date], with the consent of all the Directors present and in compliance of the provisions of the Companies Act, 1956 / 2013, passed the following Resolution:

**RESOLVED THAT** pursuant to the provisions of the Companies Act, 1956 / Companies Act, 2013 (as the case may be) and compliance thereof and as permitted under the Memorandum and Articles of Association of the company, approval of the Board be and is hereby accorded for issuing an Undertaking to the BPC, in the format specified in the RFP issued by the BPC, draft of which is attached hereto and initialed by the Chairman whereby the company undertakes to invest .....percent (... %) of the total equity share capital of ..... (Insert the name of SPV), representing the entire amount proposed to be invested by .....[insert the name of the Bidder or Member] for the said Project, in case of failure of .....[Insert the name of the Bidder or Member] to make such investment".

**FURTHER RESOLVED THAT** .....,be and is hereby authorized to take all the steps required to be taken by the Company, including in particular, signing the said Undertaking, submitting the same to the BPC through .....[Insert name of Bidding Company/Lead Member of the Consortium] of all the related documents, certified copy of this Board resolution or letter, undertakings etc, required to be submitted to BPC as part of the Bid or such other documents as may be necessary in this regard.

**Certified True Copy**

**Company rubber stamp to be affixed**

**Note:**

1. This certified true copy should be submitted on the letterhead of the Company, signed by the Company Secretary or any Whole-time Director/Manager (supported by a specific board resolution) of Bidding Company or Lead Member of the Consortium.
2. The contents of the format may be suitably re-worded indicating the identity of the entity passing the resolution.
3. This format may be modified only to the limited extent required to comply with the local regulations and laws applicable to a foreign entity submitting this resolution. For example, reference to Companies Act 1956 / Companies Act 2013 (as the case may be) may be suitably modified to refer to the law applicable to the entity submitting the resolution. However, in such case, the foreign entity shall submit an unqualified opinion issued by the legal counsel of such foreign entity, stating that the Board resolutions are in compliance with the applicable laws of the respective jurisdictions of the issuing company and the authorizations granted therein are true and valid.

**ANNEXURE 11A – ILLUSTRATION FOR APPLICABLE BOARD RESOLUTION REQUIREMENTS UNDER CLAUSE 2.5.2**

<b>Investor in the TSP</b>	<b>Entities (other than Bidder) whose credentials (financial and/or technical) used by the Bidder for meeting RFP criteria</b>	<b>Applicable Board Resolutions</b>	<b>Requirement of Undertaking (Annexure 10)</b>
Bidder himself for 100% equity	None	a) Format 1 of Annexure 11 - Resolution: 1, 2 and 4 from the Bidder	None
Bidder himself for 100% equity	Affiliate and/or Parent Company and/or Ultimate Parent	<p>a) Format 1 of Annexure 11 - Resolution: 1, 2, and 4 from the Bidder</p> <p>b) Format 2 of Annexure 11 by either Technically/ Financially Evaluated Entity(ies) whose credentials have been used, or Ultimate Parent.</p> <p>Provided, if the Bidder himself is the Ultimate Parent, then Format 2 need not be provided.</p>	<p>Yes, by either Technically / Financially Evaluated Entity(ies) Affiliate(s) whose credentials have been used, or Ultimate Parent.</p> <p>Provided, if the Bidder himself is the Ultimate Parent, then the undertaking need not be provided.</p>
Bidder himself + others (Affiliate and/or Parent Company and/or Ultimate Parent) in aggregate holding 100% equity	None	<p>a) Format 1 of Annexure 11 - Resolution: 1,2, 3 and4 from the Bidder.</p> <p>b) Format 1 of Annexure 11 - Resolution: 1 from the Affiliate and/or Parent and /or Ultimate Parent investing in the equity</p>	None
Bidder himself + others (Affiliate and/or Parent Company and/or Ultimate	Affiliate and/or Parent Company and/or Ultimate Parent	<p>a) Format 1 of Annexure 11 - Resolution: 1,2, 3 and 4 from the Bidder.</p> <p>b) Format 1 of Annexure 11 - Resolution: 1 from the Affiliate and/or Parent</p>	Yes, by either Parent/ Affiliate(s) whose credentials have been used, or Ultimate Parent

<b>Investor in the TSP</b>	<b>Entities (other than Bidder) whose credentials (financial and/or technical) used by the Bidder for meeting RFP criteria</b>	<b>Applicable Board Resolutions</b>	<b>Requirement of Undertaking (Annexure 10)</b>
Parent) in aggregate holding 100% equity		and/or Ultimate Parent investing in the equity c) Format 2 of Annexure 11 by either Parent / Affiliate(s) whose credentials have been used and /or Ultimate Parent investing in the equity	

ANNEXURE 12 - FORMAT FOR ILLUSTRATION OF AFFILIATES

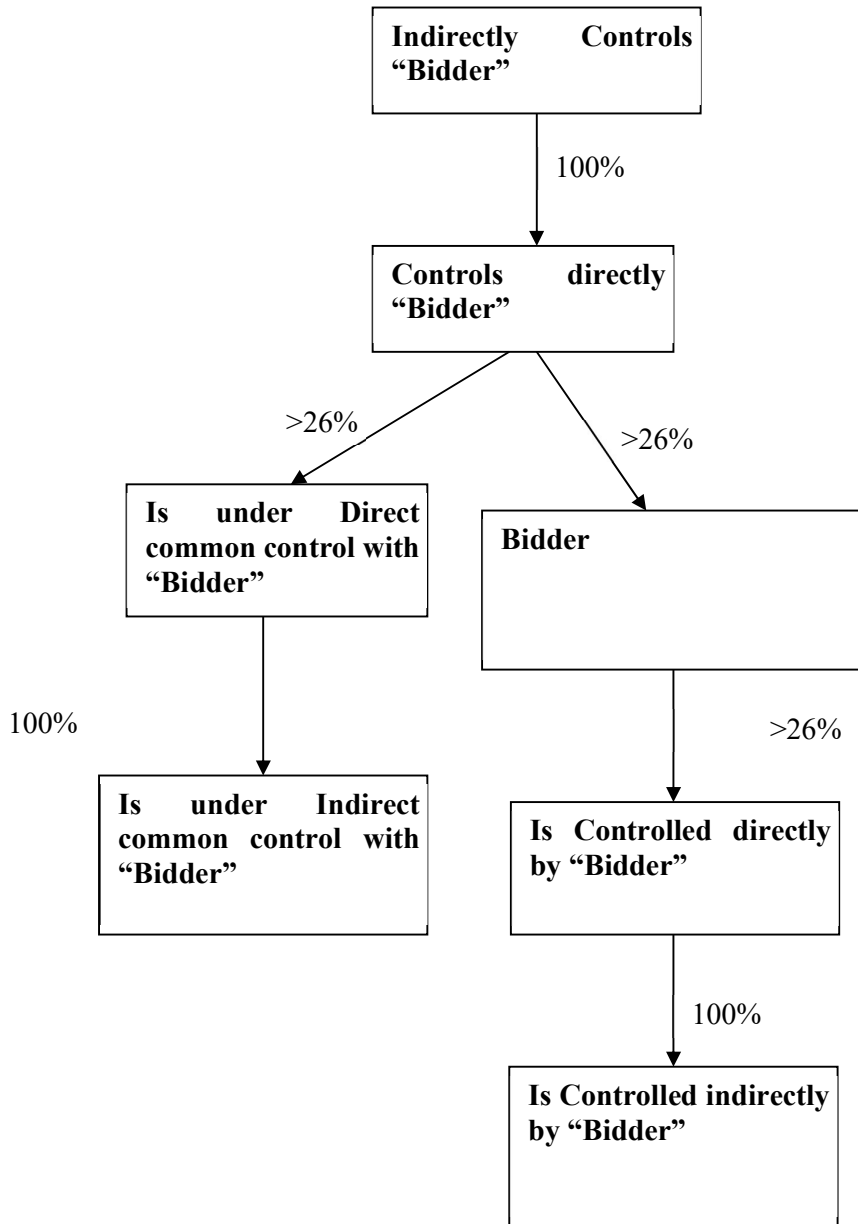

**NOTE:** Bidder to provide the illustration, as applicable in their case, duly certified by the Company Secretary and supported by documentary evidence in this regard.

**ANNEXURE 13 - FORMAT FOR DISCLOSURE**

**[On the letter head of Bidding Company / Each Member in a Bidding Consortium]**

**Date: .....**

**DISCLOSURE**

We hereby declare that the following companies with which we/ have direct or indirect relationship are also separately participating in this Bid process as per following details

<b>S. No.</b>	<b>Name of the Company</b>	<b>Relationship</b>
<b>1.</b>		
<b>2.</b>		
<b>3.</b>		

In case there is no such company please fill in the column “name of the company” as Nil.

Further we confirm that we don't have any Conflict of Interest with any other company participating in this bid process.

**Certified as True**

.....  
**(Signature)**

**Name:** .....

**Signature & Name of authorized signatory of the Company and Stamp**

The above disclosure should be signed and certified as true by the authorized signatory of the Bidding Company or of the Member, in case of a Consortium).

**ANNEXURE 14 - FORMAT OF THE BID BOND****FORMAT OF THE UNCONDITIONAL AND IRREVOCABLE BANK  
GUARANTEE FOR BID BOND**

**(To be on non-judicial stamp paper of appropriate value as per Stamp Act relevant to place of execution.)**

In consideration of the ..... [Insert name of the Bidder] submitting the Bid inter alia for establishing the Inter-State transmission system for \_\_\_\_\_ [Name of Project] on build, own, operate and transfer basis, in response to the RFP dated \_\_\_\_\_ issued by \_\_\_\_\_ [Name of BPC], and the Bid Process Coordinator (hereinafter referred to as BPC) agreeing to consider such Bid of ..... [Insert the name of the Bidder] as per the terms of the RFP, the [Insert name and address of the bank issuing the Bid Bond, and address of the Head Office] (hereinafter referred to as "Guarantor Bank") hereby agrees unequivocally, irrevocably and unconditionally to pay to \_\_\_\_\_ [Name of BPC] or its authorized representative at \_\_\_\_\_ [Address of BPC] forthwith on demand in writing from \_\_\_\_\_ [Name of BPC] or any representative authorized by it in this behalf, any amount up to and not exceeding Rupees \_\_\_\_\_ Only (Rs \_\_\_\_\_ Crore), on behalf of M/s..... [Insert name of the Bidder].

This guarantee shall be valid and binding on the Guarantor Bank up to and including ..... [Date to be inserted on the basis of Clause 2.11 of this RFP] and shall not be terminable by notice or any change in the constitution of the Guarantor Bank or by any other reasons whatsoever and our liability hereunder shall not be impaired or discharged by any extension of time or variations or alternations made, given, or agreed with or without our knowledge or consent, by or between concerned parties.

Our liability under this Guarantee is restricted to Rupees \_\_\_\_\_ Only (Rs \_\_\_\_\_ Crore). Our Guarantee shall remain in force until ..... [Date to be inserted on the basis of Clause 2.11 of this RFP]. \_\_\_\_\_ [Name of BPC] or its authorized representative shall be entitled to invoke this Guarantee until ..... [Insert Date, which is three sixty five days (365) days after the date in the preceding sentence]. The Guarantor Bank hereby expressly agrees that it shall not require any proof in addition to the written demand from \_\_\_\_\_ [Name of BPC] or its authorized representative, made in any format, raised at the above mentioned address of the Guarantor Bank, in order to make the said payment to \_\_\_\_\_ [Name of BPC] or its authorized representative.

The Guarantor Bank shall make payment hereunder on first demand without restriction or conditions and notwithstanding any objection, disputes, or disparities raised by the Bidder or any other person. The Guarantor Bank shall not require \_\_\_\_\_ [Name of BPC] or its authorized representative to justify the invocation of this BANK GUARANTEE, nor shall the Guarantor Bank have any recourse against \_\_\_\_\_ [Name of BPC] or its authorized representative in respect of any payment made hereunder.

This BANK GUARANTEE shall be interpreted in accordance with the laws of India.

The Guarantor Bank represents that this BANK GUARANTEE has been established in such form and with such content that it is fully enforceable in accordance with its terms as against the Guarantor Bank in the manner provided herein.

This BANK GUARANTEE shall not be affected in any manner by reason of merger, amalgamation, restructuring or any other change in the constitution of the Guarantor Bank.

This BANK GUARANTEE shall be a primary obligation of the Guarantor Bank and accordingly \_\_\_\_\_[Name of BPC] or its authorized representative shall not be obliged before enforcing this BANK GUARANTEE to take any action in any court or arbitral proceedings against the Bidder, to make any claim against or any demand on the Bidder or to give any notice to the Bidder to enforce any security held by \_\_\_\_\_[Name of BPC] or its authorized representative or to exercise, levy or enforce any distress, diligence or other process against the Bidder.

Notwithstanding anything contained hereinabove, our liability under this Guarantee is restricted to Rupees \_\_\_\_\_ Only (Rs \_\_\_\_ Crore) and it shall remain in force until ..... [Date to be inserted on the basis of Clause 2.11 of RFP], with an additional claim period of three hundred sixty five (365) days thereafter. We are liable to pay the guaranteed amount or any part thereof under this BANK GUARANTEE only if \_\_\_\_\_[Name of BPC] or its authorized representative serves upon us a written claim or demand.

In witness whereof the Bank, through its authorized officer, has set its hand and stamp on this..... day of ..... at.....

**Witness:**

1.....  
Name and Address

Signature: .....  
Name: .....

2. ....  
Name and Address

Designation with Stamp:

Signature .....

Attorney as per power of attorney

No.....

For:  
..... [Insert Name of the Bank]

**Banker's Stamp and Full Address:**

Dated this.....day of..... 20.....

**Notes:**

- 1. The Stamp Paper should be in the name of the Executing Bank.

**ANNEXURE 14A- FORMAT OF THE SURETY BOND FOR BID SECURITY****FORMAT OF THE SURETY BOND**

**(To be on non-judicial stamp paper of appropriate value as per Stamp Act Relevant to place of execution.)**

In consideration of the..... [Insert name of the Bidder] submitting the Bid inter alia for establishing the Inter-State transmission system for \_\_\_\_\_ [Name of Project] on build, own, operate and transfer basis, in response to the RFP dated \_\_\_ issued by \_\_\_ [Name of BPC], and the Bid Process Coordinator (hereinafter referred to as BPC) agreeing to consider such Bid of ..... [Insert the name of the Bidder] as per the terms of the RFP, the [Insert name of Surety Insurer issuing the surety bond and address of Head Office] (hereinafter referred to as "Surety Insurer") hereby agrees unequivocally, irrevocably and unconditionally to pay to \_\_\_ [Name of BPC] or its authorized representative at \_\_\_ [Address of BPC] forthwith on demand in writing from \_\_\_ [Name of BPC] or any representative authorized by it in this behalf, any amount up to and not exceeding Rupees \_\_\_\_\_ Only (Rs \_\_\_ Crore) (the "Surety Bond"), on behalf of M/s ..... [Insert name of the Bidder]

This surety bond shall be valid and binding on the Surety Insurer up to and including..... [Date to be inserted on the basis of Clause 2.11 of this RFP] and shall not be terminable by notice or any change in the constitution of the Surety Insurer or by any other reasons whatsoever and our liability hereunder shall not be impaired or discharged by any extension of time or variations or alternations made, given, or agreed with or without our knowledge or consent, by or between concerned parties.

Our liability under this Surety Bond is restricted to Rupees \_\_\_\_\_ Only (Rs \_\_\_ Crore). The Surety Bond shall remain in force until..... [Date to be inserted on the basis of Clause 2.11 of this RFP]. [Name of BPC] or its authorized representative shall be entitled to invoke this Surety bond until..... [Insert Date, which is one hundred eighty (180) days after the date in the preceding sentence]. The Surety Insurer hereby expressly agrees that it shall not require any proof except for the written demand from \_\_\_ [Name of BPC] or its authorized representative, made in any format, raised at the above mentioned address of the Surety Insurer, in order to make the said payment to \_\_\_ [Name of BPC] or its authorized representative.

The Surety Insurer shall make payment hereunder on first demand without restriction or conditions and notwithstanding any objection, disputes, or disparities raised by the Bidder or any other person. The Surety Insurer shall not require \_\_\_ [Name of BPC] or its authorized representative to justify the invocation of this surety bond, nor shall the Surety Insurer have any recourse against \_\_\_ [Name of BPC] or its authorized representative in respect of any payment made hereunder.

This Surety Bond shall be interpreted in accordance with the laws of India.

The Surety Insurer represents that this Surety Bond has been established in such form and with such content that it is fully enforceable in accordance with its terms as against the Surety Insurer in the manner provided herein.

This Surety Bond shall not be affected in any manner by reason of merger, amalgamation, restructuring, liquidation, winding up, dissolution or any other change in the constitution of the Surety Insurer.

This Surety Bond shall be a primary obligation of the Surety Insurer and accordingly \_\_\_ [Name of BPC] or its authorized representative shall not be obliged before enforcing this Surety Bond to take any action in any court or arbitral proceedings against the Bidder, to make any claim against or any demand on the Bidder or to give any notice to the Bidder to enforce any security held by \_\_\_ [Name of BPC] or its authorized representative or to exercise, levy or enforce any distress, diligence or other process against the Bidder.

The Surety Insurer declares that it has power to issue this Surety Bond and discharge the obligations contemplated herein, the undersigned is duly authorised and has full power to execute this Surety Bond for and on behalf of the Surety Insurer.

Notwithstanding anything contained hereinabove, our liability under this surety bond is restricted to Rupees \_\_\_\_\_ Only (Rs \_\_ Crore) and it shall remain in force until..... [Date to be inserted on the basis of Clause 2.11 of RFP], with an additional claim period of one hundred eighty (180) days thereafter. We are liable to pay the guaranteed amount or any part thereof under this Surety Bond only if \_\_\_ [Name of BPC] or its authorized representative serves upon us a written claim or demand.

**In witness where of:**

Signature.....

Name: .....

Power of attorney No/ Employee No. as applicable.....

For:

..... [Insert Name of the Surety-Insurance Company]

Banker's Seal and Full Address, including mailing address of the Head Office

**Notes:**

1. The Stamp Paper should be in the name of the Executing Insurance Company.

**ANNEXURE 14B - FORMAT OF PAYMENT ON ORDER INSTRUMENT  
TO BE ISSUED BY IREDA/REC/PFC**

**(to be submitted separately for each Project)**

No.

Date

..... [Insert name of BPC]  
\_\_\_\_\_

Reg: M/s \_\_\_\_ (insert name of the bidding entity)- **Issuance of Payment on Order Instrument for an amount of Rs. \_\_\_\_\_**

Dear Sir,

1. At the request of M/s..... (Insert name of the bidding entity), this Payment on Order Instrument (POI) for an amount of Rs..... (Rupees (In words)) is being issued by M/s. (Insert Name of the POI issuing Agency) ('IREDA/REC/PFC'). This Payment on Order Instrument comes into force immediately.
2. In consideration of the . . . . . [Insert name of the Bidding Entity] (hereinafter referred to as 'Bidder') submitting the response to RFP issued by [Insert name of BPC] for the project . . . . . [Insert name of the project] and [Insert name of BPC] considering such response to the RfP of M/s..... [Insert the name of Bidding Entity] as per the terms of the RFP, the..... [Insert name & address of IREDA/PFC/REC] hereby agrees unequivocally, irrevocably and unconditionally to pay to [Insert name of BPC] at [Insert Name of the Place from the address of the BPC] forthwith without demur on demand in writing from..... [Insert name of BPC] or any Officer authorized by it in this behalf, any amount up to and not exceeding Rupees [Insert amount not less than the bid bond value indicated in RFP] only, on behalf of M/s. [Insert name of the Bidding Entity].
3. In consideration of the above facts, IREDA/REC/PFC, having its registered office at ..... agrees to make payment for the sum of Rs (in words ..... ) to..... [Insert name of BPC] on the following conditions:
  - (a) IREDA/REC/PFC agrees to make payment of the above said amount unconditionally, without demur and without protest within a period of \_\_\_\_ days of receipt of request from [Insert name of BPC] within the validity period of this letter as specified herein;
  - (b) The commitment of IREDA/REC/PFC, under this Payment on Order Instrument will have the same effect as that of the commitment under the Bank Guarantee issued by any Public Sector Bank and shall be enforceable in the same manner as in the case of a Bank Guarantee issued by a Bank and the same shall be irrevocable and shall be honored irrespective of any agreement or its breach between

IREDA/REC/PFC or its constituents notwithstanding any dispute that may be raised by them against [Insert name of BPC];

(c) The liability of IREDA/REC/PFC continues to be valid and binding on IREDA/REC/PFC and shall not be terminated, impaired, and discharged by virtue of change in its constitution and specific liability under this POI shall be binding on its successors or assignors;

(d) The liability of IREDA/REC/PFC shall continue to be valid and binding on IREDA/REC/PFC and shall not be terminated/impaired/discharged by any extension of time or variation and alteration made, given or agreed with or without knowledge or consent of the parties ([Insert name of BPC] and Bidder), subject however to the maximum extent of amount stated herein and IREDA/REC/PFC is not liable to any interest or costs etc.;

(e) This Payment on Order Instrument can be invoked either partially or fully, till the date of validity;

(f) IREDA/REC/PFC agrees that it shall not require any proof in addition to the written demand by [Insert name of BPC] made in any format within the validity period. IREDA/REC/PFC shall not require [Insert name of BPC] to justify the invocation of the POI against the Bidder, to make any claim against or any demand against the Bidder or to give any notice to the Bidder;

(g) The POI shall be the primary obligation of IREDA/REC/PFC and..... [Insert name of BPC] shall not be obliged, before enforcing the POI, to take any action in any court or arbitral proceedings against the Bidder;

(h) The POI shall not be affected in any manner by reason of merger, amalgamation, restructuring or any other changes in constitution of IREDA/REC/PFC;

(i) Neither the..... [Insert name of BPC] is required to justify the invocation of this POI nor shall IREDA/REC/PFC have any recourse against the..... [Insert name of BPC] in respect of the payment made under this POI.

4. Notwithstanding anything contrary contained anywhere in this POI or in any other documents, this POI is and shall remain valid up to [Insert the date of validity of the POI as per Clause 2.11.1 of the RFP], with an additional claim period of three hundred and sixty-five (365) days thereafter and IREDA/REC/PFC shall make payment thereunder only if a written demand or request is raised within the said date and to the maximum extent of Rs ..... and IREDA/REC/PFC shall in no case be liable for any interest, costs, charges, and expenses and IREDA's/REC's/PFC's liability in no case will exceed more than the above amount stipulated.
5. In pursuance of the above, IREDA/REC/PFC and [Insert name of BPC] have signed an Umbrella Agreement dated ..... Setting out the terms and conditions for issue of letter of undertaking by IREDA/REC/PFC to..... [Insert name of BPC] and the said terms and conditions shall be read as a part of this POI issued for the project of PP mentioned above.

Thanking you,

Yours faithfully

For and on behalf of

M/s.....

(Name of the POI issuing agency)

( )  
General Manager

Copy to

M/s ..... as per their request

( )  
General Manager

**ANNEXURE 15 - FORMAT FOR CONTRACT PERFORMANCE GUARANTEE**

**(To be on non-judicial stamp paper of appropriate value as per Stamp Act relevant to place of execution.**

**Foreign entities submitting Bids are required to follow the applicable law in their country)**

In consideration of the ..... [Insert name of the SPV or Selected Bidder on behalf of SPV or Lead Member in case of the Consortium, with address] agreeing to undertake the obligations under the Transmission Service Agreement dated ..... and the other RFP Project Documents and the Nodal Agency and ..... [Name of BPC], agreeing to execute the RFP Project Documents with the Selected Bidder, regarding setting up the Project, the.....[Insert name and address of the bank issuing the guarantee and address of the head office] (hereinafter referred to as "Guarantor Bank") hereby agrees unequivocally, irrevocably and unconditionally to pay to the Nodal Agency at..... [Insert Place and Address of the Nodal Agency indicated in TSA] forthwith on demand in writing from the Nodal Agency or any Officer authorized by it in this behalf, any amount up to and not exceeding Rupees.....Crores (Rs.....) only [Insert the amount of the bank guarantee] on behalf of M/s..... [Insert name of the Selected Bidder / SPV].

This guarantee shall be valid and binding on the Guarantor Bank up to and including .....and shall not be terminable by notice or any change in the constitution of the Bank or the term of the Transmission Service Agreement or by any other reasons whatsoever and our liability hereunder shall not be impaired or discharged by any extension of time or variations or alternations made, given, or agreed with or without our knowledge or consent, by or between parties to the respective agreement.

Our liability under this Guarantee is restricted to Rupees ..... Crores (Rs.....) only. Our Guarantee shall remain in force until..... [Insert the date of validity of the Guarantee as per Clause 2.12.1 of the RFP]. The Nodal Agency shall be entitled to invoke this Guarantee up to three hundred sixty five (365) days of the last date of the validity of this Guarantee.

The Guarantor Bank hereby expressly agrees that it shall not require any proof in addition to the written demand from the Nodal Agency, made in any format, raised at the above mentioned address of the Guarantor Bank, in order to make the said payment to the Nodal Agency.

The Guarantor Bank shall make payment hereunder on first demand without restriction or conditions and notwithstanding any objection by ..... [Insert name of the SPV, ..... [Insert name of the Selected Bidder], ..... [Insert name of the TSP] and/or any other person. The Guarantor Bank shall not require the Nodal Agency to justify the invocation of this BANK GUARANTEE, nor shall the Guarantor Bank have any recourse against the Nodal Agency in respect of any payment made hereunder.

**This BANK GUARANTEE shall be interpreted in accordance with the laws of India.**

The Guarantor Bank represents that this BANK GUARANTEE has been established in such form and with such content that it is fully enforceable in accordance with its terms as against the Guarantor Bank in the manner provided herein.

**This BANK GUARANTEE** shall not be affected in any manner by reason of merger, amalgamation, restructuring, liquidation, winding up, dissolution or any other change in the constitution of the Guarantor Bank.

**This BANK GUARANTEE** shall be a primary obligation of the Guarantor Bank and accordingly the Nodal Agency shall not be obliged before enforcing this BANK GUARANTEE to take any action in any court or arbitral proceedings against ..... [Insert name of the SPV], or the Selected Bidder, to make any claim against or any demand on ..... [Insert name of the SPV], or the Selected Bidder, as the case may be, or to give any notice to ..... [Insert name of the SPV], or the Selected Bidder, as the case may be, or to enforce any security held by the Nodal Agency or to exercise, levy or enforce any distress, diligence or other process against ..... [Insert name of the SPV], or the Selected Bidder, as the case may be.

The Guarantor Bank acknowledges that this BANK GUARANTEE is not personal to the Nodal Agency and may be assigned, in whole or in part, (whether absolutely or by way of security) by Nodal Agency to any entity to whom the Nodal Agency is entitled to assign its rights and obligations under the Transmission Service Agreement.

The Guarantor Bank hereby agrees and acknowledges that the Nodal Agency shall have a right to invoke this Bank Guarantee either in part or in full, as it may deem fit.

Notwithstanding anything contained hereinabove, our liability under this Guarantee is restricted to Rupees .....Crores (Rs .....) only and it shall remain in force until [Date to be inserted on the basis of Article 3.1.2 of TSA], with an additional claim period of three hundred sixty five (365) days thereafter. This BANK GUARANTEE shall be extended from time to time for such period, as may be desired by..... [Insert name of the Selected Bidder or Lead Member in case of the Consortium or SPV]. We are liable to pay the guaranteed amount or any part thereof under this Bank Guarantee only if the Nodal Agency serves upon us a written claim or demand.

**In witness where of:**

Signature.....

Name: .....

Power of attorney No.: .....

**For:**

..... [Insert Name of the Bank]

Banker's Seal and Full Address, including mailing address of the Head Office

**Notes:**

- 1. The Stamp Paper should be in the name of the Executing Bank.

**ANNEXURE 15A -FORMAT FOR SURETY INSURANCE CONTRACT****(ISB for CPG)**

**(To be on non-judicial stamp paper of appropriate value as per Stamp Act relevant to place of execution.**

**Foreign entities submitting Bids are required to follow the applicable law of India)**

In consideration of the..... [Insert name of the SPV or Selected Bidder on behalf of SPV or Lead Member in case of the Consortium, with address] (hereinafter referred to as the 'Principal Debtor' for the purposes of this Surety Insurance Contract as provided in Section 126 of the Indian Contract Act, 1872) having been selected to undertake the Transmission Project on the terms and conditions contained in the Transmission Service Agreement dated..... / to be executed as per the Model Transmission Service Agreement provided along with the Request for Proposal ('RFP') and other RFP Project Documents, subject to the condition of providing a Performance Bank Guarantee or a Surety Insurance Contract guaranteeing/insuring the due performance of the obligations under the Transmission Service Agreement, to the Central Transmission Utility of India Limited ('CTUIL') [herein after referred to as the Nodal Agency], the [Insert name and address of the Insurance Company issuing the Surety Insurance Contract and address of the head office] (hereinafter referred to as "Surety") hereby agrees unequivocally, irrevocably, absolutely and unconditionally, without demur, to pay to the Nodal Agency at [Insert Place and Address of the Nodal Agency indicated in Transmission Service Agreement, or to the designated Bank Account of the Nodal Agency, namely ..... ] forthwith on demand in writing from the Nodal Agency, or any Officer authorized by it in this behalf, intimated to the Surety at the address mentioned above, any amount as may be decided by the Nodal Agency not exceeding Rupees ..... Crores (Rs ..... ) only [Insert the amount of the Surety Insurance Contract]

The Surety hereby acknowledges, accepts and confirms that the Surety has received from the Principal Debtor, by way of premium the entire consideration for the Surety to execute, in favour of the Nodal Agency, this Surety Insurance Contract, as extended by the Surety from time to time and assuming the obligation to pay to the Nodal Agency the amount in terms hereof, without any requirement for payment of any other consideration to the Surety by the Principal Debtor, or otherwise.

This Surety Insurance Contract shall be valid and binding on the Surety, as the principal obligation of the Surety to pay on demand by the Nodal Agency, and shall not be terminable by notice or any change in the constitution of the Surety or the term of the Transmission Service Agreement or by any other reasons whatsoever and the liability hereunder of the Surety shall not be impaired or discharged by any extension of time or variations or alternations made, given, or agreed (with or without the knowledge or consent of the Surety) by or between the Principal Debtor and the Nodal Agency.

The liability of the Surety under this Surety Insurance Contract is restricted to Rupees ..... Crores (Rs ..... ) only. The Surety Insurance Contract shall remain in force until [Insert the date of validity of the Surety Insurance Contract]. The Nodal Agency shall be entitled to invoke this Surety Insurance Contract up to three hundred sixty five (365) days after the last date of the validity of this Surety Insurance Contract.

The Surety hereby expressly agrees that it shall not require any proof except for the written demand from the Nodal Agency, containing the statement that the contractor has failed to meet its contractual obligations raised at the above mentioned address of the Surety (address of Surety office should be a place in NCR only) and the Surety shall pay the amount without reference to the Principal Debtor.

Any such demand made by the Nodal Agency on the Surety shall be conclusive and binding not withstanding any difference between the Nodal Agency and the Principal Debtor or any dispute pending before any Court, Tribunal, Arbitrator or any other authority. The Surety undertakes not to revoke this guarantee during its currency without previous consent of the Nodal Agency and further agrees that the Surety Insurance Contract herein contained shall continue to be enforceable till the Nodal Agency discharges this contract or till the expiry of tenor(including Claim period) whichever is earlier.

The Surety shall make payment hereunder within two (02) working days on first demand without restriction or conditions and notwithstanding any objection by the Principal Debtor, namely, ..... [Insert name of SPV], or ..... [Insert name of the Selected Bidder], or..... [Insert name of the TSP] and/or any other person. The Surety shall not require the Nodal Agency to justify the invocation of this Surety Insurance Contract, nor shall the Surety have any recourse against the Nodal Agency in respect of any payment made hereunder.

**This SURETY INSURANCE CONTRACT** shall be interpreted in accordance with the laws of India.

**This SURETY INSURANCE CONTRACT** is being executed by the Surety in terms of the IRDAI (Surety Insurance Contract) Guidelines, 2022 and the Surety hereby acknowledges, accepts and confirms that this Surety Insurance Contract shall be a Contract of Guarantee as provided under Section 126 of the Indian Contract Act, 1872 and further shall be covered by Section 14(3)(b) of the Insolvency and Bankruptcy Code, 2016 (as amended) shall be enforceable as such.

The Surety represents that this Surety Insurance Contract has been established in such form and with such content that it is fully enforceable in accordance with its terms as against the Surety in the manner provided herein.

**This SURETY INSURANCE CONTRACT** shall not be affected in any manner by reason of merger, amalgamation, restructuring, liquidation, winding up, dissolution or any other change in the constitution of the Surety.

In order to give effect to this surety Bond, the Nodal Agency shall be entitled to act as if the surety insurer were the principal debtor and any change in the constitution of the contractor and/or the surety insurer, whether by their absorption with any other body or corporation or otherwise, shall not in any way or manner affect the liability or obligation of the surety insurer under this surety Bond.

**This SURETY INSURANCE CONTRACT** shall be a primary obligation of the Surety as a Principal to pay on demand by the Nodal Agency and the Nodal Agency shall not be obliged before enforcing this Surety Insurance Contract to take any action in any court or arbitral proceedings against the Principal Debtor, namely, ..... [Insert name of SPV], or ..... [Insert name of the Selected Bidder], or ..... [Insert name of the TSP] and/or any other person, as the case may be, to make any claim against or any demand on the Principal Debtor,

namely, ..... [Insert name of SPV], or ..... [Insert name of the Selected Bidder], or ..... [Insert name of the TSP] and/or any other person, as the case may be, or to give any notice to Principal Debtor, namely..... [Insert name of SPV], or ..... [Insert name of the Selected Bidder], or ... ..... [Insert name of the TSP] and/or any other person, as the case may be, or to enforce any security held by the Nodal Agency or to exercise, levy or enforce any distress, diligence or other process against the Principal Debtor, namely, ..... [Insert name of SPV], or ..... [Insert name of the Selected Bidder], or..... [Insert name of the TSP] and/or any other person, as the case may be.

The Surety acknowledges that this Surety Insurance Contract is not personal to the Nodal Agency and may be assigned, in whole or in part, (whether absolutely or by way of security) by Nodal Agency to any entity to whom the Nodal Agency is entitled to assign its rights and obligations under the Transmission Service Agreement Provided that any such assignment shall be in compliance with the relevant provisions of the Insurance Act 1938

The Surety hereby agrees and acknowledges that the Nodal Agency shall have a right to invoke this Surety Insurance Contract either in part or in full, as it may deem fit. In case of invocation of this Surety Insurance Contract in part, besides making payment for the part of Surety Insurance Contract invoked, surety at the request of nodal agency shall amend the value of Surety Insurance Contract to the extent of balance amount.

The Surety undertakes not to revoke this Surety Contract during its currency, except with the previous express consent of the Nodal Agency in writing and declares and warrants that it has the power to issue this Surety Contract and the undersigned has full powers to do so on behalf of the Surety

**In witness where of:**

Signature.....

Name: .....

Power of attorney No/ Employee No. as applicable.....

**For:**

..... [Insert Name of the Surety-Insurance Company  
Banker's Seal and Full Address, including mailing address of the Head Office

**Notes:**

1. The Stamp Paper should be in the name of the Executing Insurance Company.

**ANNEXURE 15B -FORMAT FOR ISSUANCE OF PAYMENT ON ORDER  
INSTRUMENT  
(POI for CPG)**

**Format for Issuance of Payment on Order Instrument**

Dear Sir,

1. Indian Renewable Energy Development Agency Limited ("IREDA")/PFC/REC has sanctioned a non-fund based limit loan of Rs. (Rupees..... Only) to M/s. . . . . [Insert name of SPV or selected Bidder] under the Loan Agreement executed on ..... to execute Transmission System Projects.
2. In consideration of the..... [Insert name of the SPV or Selected Bidder on behalf of SPV or Lead Member in case of the Consortium, with address] for the purposes of this Payment on Order Instrument ("POI") having been selected to undertake the Transmission Project on the terms and conditions contained in the Transmission Service Agreement dated..... / to be executed as per the draft of the Model Transmission Service Agreement provided along with the Request for Proposal („RFP") and other RFP Project Documents, subject to the condition of providing a POI guaranteeing the due performance of the obligations under the Transmission Service Agreement to the Nodal Agency/Central Transmission Utility of India Limited („CTUIL"),the ..... [Insert name and address of the non-banking financial institutions(IREDA/PFC/REC) issuing the POI and address of the head office] (hereinafter referred to as "**Guarantor**") hereby agrees unequivocally, irrevocably, absolutely and unconditionally, without demur, to pay to the Nodal Agency at ..... [Insert Place and Address of the Nodal Agency indicated in Transmission Service Agreement, or to the designated Bank Account of the Nodal Agency, namely ..... ] forthwith on demand in writing from the Nodal Agency, or any Officer authorized by it in this behalf, intimated to the Guarantor at the address mentioned above, any amount as may be decided by the Nodal Agency not exceeding Rupees ..... Crores (Rs ) only [Insert the amount of Payment on Order Instrument]
3. At the request of ..... and on behalf of M/s....., [Insert name of SPV or selected Bidder] this Payment on Order Instrument (POI) for an amount of Rs..... (Rupees ..... ) is being issued with IREDA/PFC/REC assuming the obligations to remit such amount to CTUIL from the sanctioned loan.
4. This Payment on Order Instrument comes into force immediately and IREDA/PFC/REC confirms that it has sufficient amount out of the sanctioned loan and shall maintain the required amount to pay under this Payment on Order Instrument, during the validity and claim period of this Payment on Order Instrument.
5. This POI has been issued by IREDA/PFC/REC utilizing the credit limit of M/s..... [Insert name of SPV or selected Bidder] IREDA/PFC/REC confirms that its liability to pay under this Payment on Order Instrument shall be primary and independent of whether at the time of invocation of Payment on Order Instrument, the sanctioned funds are available or not and

notwithstanding, the status of M/s . ..... [Insert name of SPV or selected Bidder] at the relevant time and to whether IREDA/PFC/REC is able to recover the amount advanced by it to the said developer.

6. IREDA/PFC/REC and M/s. [Insert name of SPV or selected Bidder] hereby acknowledges, accepts and confirms that this Payment on Order Instrument shall be a Contract of Guarantee as provided under Section 126 of the Indian Contract Act, 1872 and further shall be covered by Section 14(3)(b) of the Insolvency and Bankruptcy Code, 2016 (as amended) shall be enforceable as such.
7. IREDA/PFC/REC liability under this POI is restricted to Rupees Crores (Rs ..... ) only. This POI shall remain in force until. .... [Insert the date of validity of the POI]. The Nodal Agency shall be entitled to invoke this POI up to three hundred sixty-five (365) days after the last date of the validity of this POI. This POI shall be extended from time to time for such period, as may be desired by the TSP.
8. The Guarantor hereby expressly agrees that it shall not require any proof except for the written demand from the Nodal Agency, raised at the above-mentioned address of the Guarantor (address of Guarantor office should be in NCR only) and the Guarantor shall pay the amount to the Nodal Agency without reference to the TSP.
9. Any such demand made by the Nodal Agency on the Guarantor shall be conclusive and binding notwithstanding any difference between the Nodal Agency and the TSP or any dispute pending before any Court, Tribunal, Arbitrator or any other authority. The Guarantor undertakes not to revoke this guarantee during its currency without previous consent of the Nodal Agency and further agrees that the POI herein contained shall continue to be enforceable till the Nodal Agency discharges this contract or till the expiry of tenure or (including Claim period) whichever is earlier.
10. The Guarantor shall make payment hereunder within two (02) working days on first demand without restriction or conditions and notwithstanding any objection or disputes raised by the TSP, namely,..... [Insert name of SPV], or [Insert name of the Selected Bidder], or.. .. [Insert name of the TSP] and/or any other person. The Guarantor shall not require the Nodal Agency to justify the invocation of this POI, nor shall the Guarantor have any recourse against the Nodal Agency in respect of any payment made hereunder.
11. This POI shall be interpreted in accordance with the laws of India.
12. The Guarantor represents that this POI Contract has been established in such form and with such content that it is fully enforceable in accordance with its terms as against the Guarantor in the manner provided herein.
13. This POI shall not be affected in any manner by reason of merger, amalgamation, restructuring, liquidation, winding up, dissolution or any other change in the constitution of the Guarantor.
14. This POI Contract shall be a primary obligation of the Guarantor as a Principal to pay on demand by the Nodal Agency and the Nodal Agency shall not be obliged before enforcing this POI Contract to take any action in any court or arbitral proceedings

against the TSP, namely,..... [Insert name of SPV], or..... [Insert name of the Selected Bidder], or..... [Insert name of the TSP] and/or any other person, as the case may be to make any claim against or any demand on the TSP, namely, ..... [Insert name of SPV], or ..... [Insert name of the Selected Bidder], or ..... [Insert name of the TSP] and/or any other person, as the case may be, or to give any notice to TSP, namely,..... [Insert name of SPV], or..... [Insert name of the Selected Bidder], or..... [Insert name of the TSP] and/or any other person, as the case may be, or to enforce any security held by the Nodal Agency or to exercise, levy or enforce any distress, diligence or other process against the TSP, namely, ..... [Insert name of SPV], or.[Insert name of the Selected Bidder], or ..... [Insert name of the TSP] and/or any other person, as the case may be.

- 15. The Guarantor acknowledges that this POI Contract is not personal to the Nodal Agency and may be assigned, in whole or in part, (whether absolutely or by way of security) by Nodal Agency to any entity to whom the Nodal Agency is entitled to assign its rights and obligations under the Transmission Service Agreement.
- 16. The Guarantor hereby agrees and acknowledges that the Nodal Agency shall have a right to invoke this POI Contract either in part or in full, as it may deem fit. In case of invocation of this POI Contract in part, besides making payment for the part of POI Contract invoked, Guarantor at the request of Nodal Agency shall amend the value of POI Contract to the extent of balance amount.

IN WITNESS WHERE OF the non- banking financial institutions through its authorized officer, has set its hand and stamp on this ..... day of..... at .....

Signature.....

Name:

.....

Power of attorney No.:

..... For:

... [Insert Name of the non- banking financial institutions Company]

Seal and Full Address, including mailing address of the Head Office.

## ANNEXURE 16 – FORMAT OF CHECKLIST FOR TECHNICAL BID SUBMISSION REQUIREMENTS

[This format needs to be duly filled in, signed by the authorized signatory of the Bidder (Bidding Company / Lead Member in case of a Bidding Consortium) and submitted along with the Bidder's Technical Bid]

Technical Bid Submission Requirements	Response (Yes / No)
<ol style="list-style-type: none"> <li>1. Format for the Covering Letter on the letterhead of Bidding Company or Lead Member of the Consortium, as applicable;</li> <li>2. Format for Letter of Consent from each Consortium Member, including Lead Member, on their respective letterheads;</li> <li>3. Format for evidence of authorized signatory's authority ;</li> <li>4. Board resolution from the Bidding Company / Lead Member of the Consortium in favour of the person executing the Power of Attorney as per <b>Annexure 3</b>;</li> <li>5. Power of Attorney from each Consortium Member in favour of Lead Member to be provided by each of the other Members of the Consortium as per <b>Annexure 4</b>;</li> <li>6. Board Resolution from each Member of the Consortium, other than the Lead Member, in favour of their respective authorized representatives for executing the POA, Consortium Agreement and signing of the requisite formats;</li> <li>7. Format for Bidder's composition and ownership structure, along with status of equity holding (owning ten percent or more of the total paid up equity) not earlier than thirty (30) days prior to the Bid Deadline as per <b>Annexure 5</b>;</li> <li>8. Consortium Agreement duly signed as per <b>Annexure 6</b>, along with Appendix-1, indicating the responsibilities and obligations of each Member of the Consortium;</li> <li>9. Format for Qualification Requirement:               <ol style="list-style-type: none"> <li>a. Calculation sheets, detailing computation of Networth considered for meeting Qualifying Requirements, duly signed and stamped by the Statutory Auditor of the Bidding Company / each Member in case of a Bidding Consortium / FEE in cases where credentials of FEE is taken;</li> <li>b. Calculation sheets, detailing computation of capital expenditure of projects and revenue received in construction projects considered for meeting Qualification Requirements, duly signed and stamped by the Statutory Auditor of the Bidding Company / Lead Member in case of Bidding Consortium / TEE in cases where credentials of TEE is taken;</li> </ol> </li> </ol>	

Technical Bid Submission Requirements	Response (Yes / No)
<p>c. Last financial year unconsolidated / consolidated audited annual accounts / statements, as the case may be, of the Financially Evaluated Entity / Technical Evaluated Entity</p> <p>d. Unconsolidated audited annual accounts of both the TEE and the Bidding Company/Lead member, as applicable, from the financial years in which financial closure was achieved till the financial year in which the said project was completed / commissioned.</p> <p>10. Copy of the Memorandum and Articles of Association and certificate of incorporation or other organizational document (as applicable), including their amendments, certified by the Company Secretary of Bidding Company or each Member in case of a Consortium including Lead Member.</p> <p>11. Attachment of <b>Annexure 7(D)</b>, detailing projects completed / commissioned and for which commercial operation has commenced including Executive Summary for each project.</p> <p>12. For each project listed in the attachment above, certified true copy of the certificates of final acceptance and / or certificates of good operating performance duly issued by owners or clients for the project, duly signed by authorized signatory in support of technical capability as defined in Clause 2.1.2 of RFP.</p> <p>13. Authority letter in favour of BPC from the Bidder/every Member of the Consortium authorizing the BPC to seek reference from their respective bankers &amp; others.</p> <p>14. Authorization from Parent / Affiliate of Bidding Company / Member of Bidding Consortium whose technical / financial capability has been used by the Bidding Company / Member of Bidding Consortium.</p> <p>15. Initialing of all pages of Technical Bid by the Authorized Signatory in whose favour the POA (<b>Annexure 3</b>) has been executed.</p> <p>16. Format for Illustration of Affiliates at the most seven (7) days prior to the Bid Deadline, duly certified by Company Secretary and supported by documentary evidence.</p> <p>17. Certified copy of the Register of Members / Demat Account Statement, Share Certificate, Annual Return filed with ROC etc. submitted as documentary evidence along with <b>Annexure 12</b>.</p> <p>18. Format for Disclosure by Bidding Company / each Member of the Consortium.</p> <p>19. Format for Affidavit by the Bidding Company / each Member of the Consortium</p>	

Technical Bid Submission Requirements	Response (Yes / No)
20. Format for Authorization submitted in Non-Judicial stamp paper duly notarized.	
21. Bidders Undertaking and details of Equity Investment	
22. Proof of Payment of RFP Fees	
23. Bid Bond/Surety Bond/Payment on Order Instrument	
24. Board Resolution as per Annexure 11 (If required)	

[**Note:** The checklist is not exhaustive. Bidders are required to submit all the information/documents as per requirement of RFP]

**For and on behalf of Bidder**

**M/s.** .....

.....  
**(Signature of authorized signatory)**

## ANNEXURE 17 – LIST OF BANKS

All Scheduled Commercial Banks as per Second Schedule of RBI Act-1934 and any amendments thereof.

**ANNEXURE 18 - GRID MAP OF THE PROJECT**

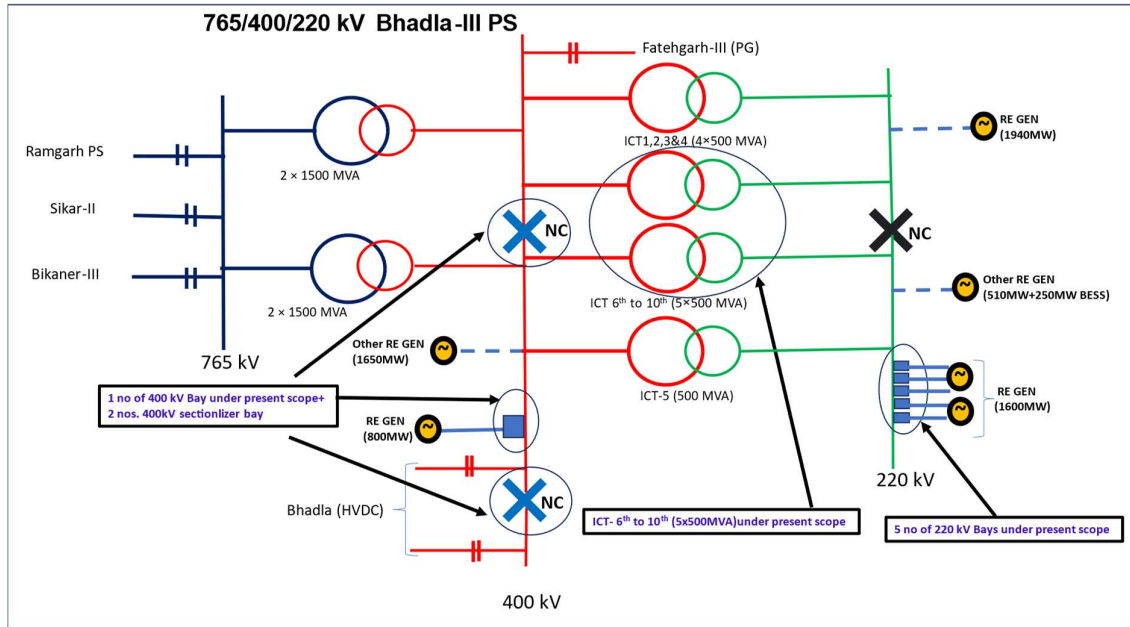

**Fig-schematic of 765/400/220 kV Bhadla-III PS**

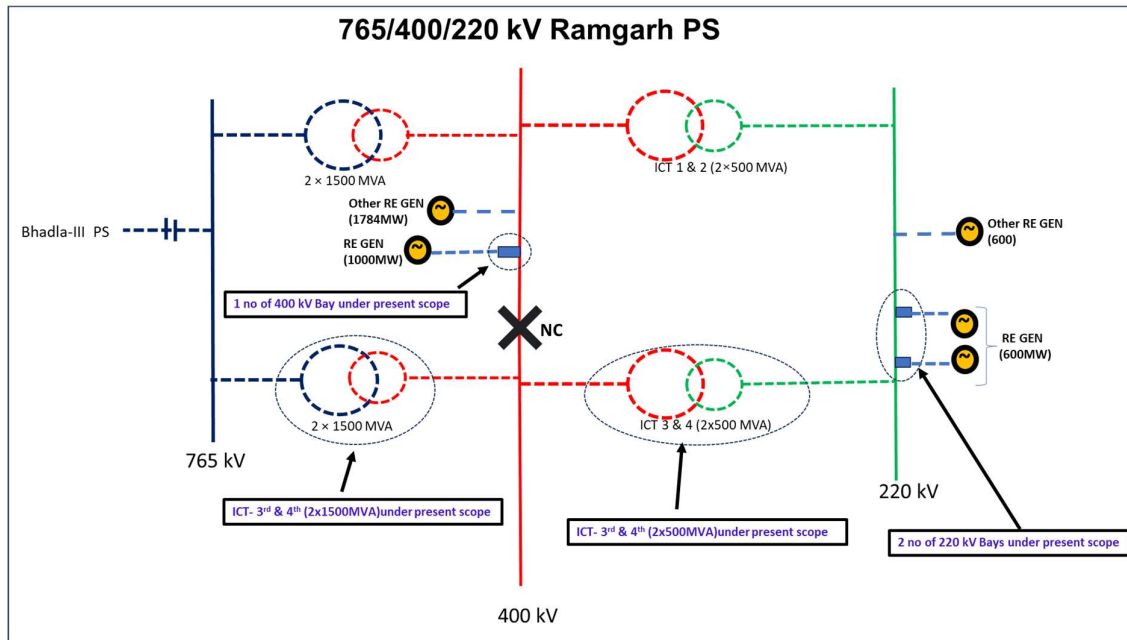

**Fig-schematic of 765/400/220 kV Ramgarh PS**

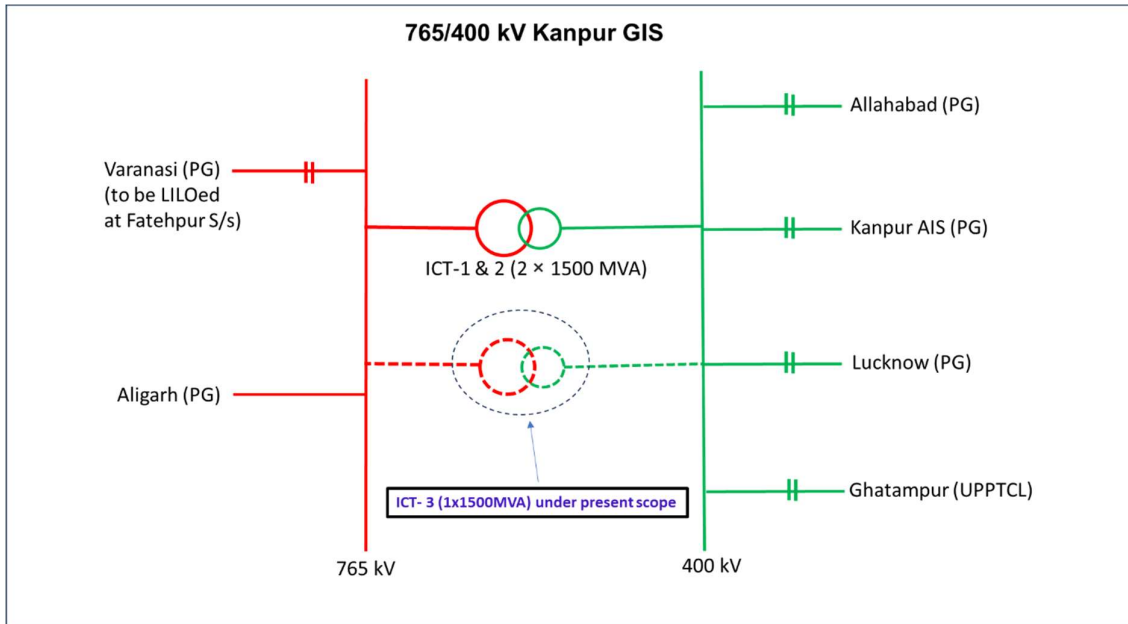

**Fig-schematic of 765/400 kV Kanpur S/s**

**ANNEXURE 19 - FORMAT FOR CLARIFICATIONS / AMENDMENTS ON THE RFP / RFP PROJECT DOCUMENTS**

<b>S. No.</b>	<b>Name of the Document</b>	<b>Clause No. and Existing provision</b>	<b>Clarification required</b>	<b>Suggested text for the amendment</b>	<b>Rationale for the Clarification or Amendment</b>

Signature .....

Name.....

For

**Bidder's Rubber Stamp and Full Address.**

(Note: This format shall be used for submission of requests for clarifications/ amendments on the draft RFP Project Documents as per the provisions of Clause 2.3.1)

**ANNEXURE 20 - LIST FOR RFP PROJECT DOCUMENTS**

**ENCLOSURE 1: TRANSMISSION SERVICE AGREEMENT (Provided separately)**

**ENCLOSURE 2: SHARE PURCHASE AGREEMENT (Provided Separately)**

**ANNEXURE 21 - FORMAT FOR FINANCIAL BID**

**[To be uploaded online]**

**Quoted Transmission Charges .....**

**Notes**

1. The Bidders are required to ensure compliance with the provisions of Clause 2.5.3 of this RFP.
2. Quotes to be in Rupees Millions and shall be up to two (2) decimal points.
3. The contents of this format shall be clearly typed.
4. The Financial Bid shall be digitally signed by the authorized signatory in whose name power of attorney as per Clause 2.5.2 is issued.
5. Ensure only one value for annual Transmission Charges is quoted. The same charge shall be payable every year to TSP for the term of TSA.

**ANNEXURE 22 – FORMAT FOR AFFIDAVIT**

**[On non-judicial stamp paper. Foreign companies submitting bids are required to follow the applicable law in their country]**

**AFFIDAVIT**

We [including any of our Affiliate and Consortium Member & any of its Affiliate], hereby declare that as on Bid Deadline:

- a. the Bidder & any of its Affiliate including any Consortium Member & any of its Affiliate, their directors or key personnel have not been barred or included in the blacklist by any government agency or authority in India, the government of the jurisdiction of the Bidder or Members where they are incorporated or the jurisdiction of their principal place of business, any international financial institution such as the World Bank Group, Asian Development Bank, African Development Bank, Inter-American Development Bank, Asian Infrastructure Investment Bank etc. or the United Nations or any of its agencies; or
- b. the Bidder & any of its Affiliate including any Consortium Member & any of its Affiliate or their directors have not been convicted of any offence in India or abroad.

We further declare that following investigations are pending / no investigation is pending [strike off whichever is not applicable] against us [including any of our Consortium Member or Affiliate or Parent or Ultimate Parent or Affiliate] or CEO or any of our directors/ manager/key managerial personnel of the Applicant /Consortium Member or their Affiliates.

We further undertake to inform the BPC of any such matter as mentioned above on its occurrence after the date of this affidavit till the Effective Date.

We undertake that, in case, any information provided in relation to this affidavit is found incorrect at any time hereafter, our BID / Letter of Intent / contract (if entered) would stand rejected / recalled / terminated, as the case may be.

.....  
Signature and Name of the authorized signatory of the Company Bidding Company / Lead Member of the Bidding Consortium

.....  
(Signature of Notary Public)

Place: .....  
Date: .....

Note: In case any investigation is pending against the Applicant, including any Consortium Member or Affiliate, or CEO or any of the directors/ manager/key managerial personnel of the Applicant /Consortium /Member or their Affiliates, full details of such investigation including

the name of the investigating agency, the charge/offence for which the investigation has been launched, name and designation of persons against whom the investigation has been launched and other relevant information should be disclosed under this affidavit.

<b>ANNEXURE A</b>
-------------------

Technical Details with respect to electronic bidding
--

### **Registration Methodology**

In order to submit online bids in the e-bidding process for selection of Transmission Service Provider, interested Bidders are required to register themselves with the e-procurement website of MSTC limited namely [www.mstcecommerce.com/eprochome/tsp/index.jsp](http://www.mstcecommerce.com/eprochome/tsp/index.jsp). To register with the website, the Bidder is required to fill up the online form available under the link Register as Vendor in the above website and fill up the same and click on Submit.

During this process, the bidder shall create his user id and password and keep note of the same. The bidder shall ensure that the secrecy of his user id and password is maintained at all time and he/she shall alone be responsible for any misuse of the user id and password.

The bidder may check the details entered by it before final submission. On successful submission of the online registration Form, the bidder shall receive a confirmation mail in the registered email address advising the bidder to submit the following documents.

- i. Self-attested Income Tax PAN Card. In case of a registered Company or Firm, the Firm's PAN card and in case of a proprietorship firm, proprietor's personal PAN card is required. In case of partnership firm, PAN of the firm and that of the authorized partner are to be submitted.
- ii. Copy of the confirmation email Letter received from MSTC after successful completion of on-line registration.
- iii. A non-refundable registration fee of Rs 10,000/- plus applicable GST to be paid online.

Please provide details of payment made like UTR No, remitting bank name, date of payment and amount in the covering letter.

The bidder shall have to submit all the above documents to MSTC Limited for verification and activation of their login ids. The bidders should send scanned copies of the above documents to the designated email id only which is given below:

**[tsp@mstcindia.co.in](mailto:tsp@mstcindia.co.in)**

It may be noted that bidders need not visit any of the offices of MSTC Limited for submission of the documents.

Contact persons of MSTC Limited:

**Mr. Setu Dutt Sharma, 7878055855**

Once the complete set of documents and requisite registration fee are received from a bidder, MSTC shall activate the bidder's login after verification / scrutiny of the documents. MSTC Limited reserves the right to call for additional documents from the bidder if needed and the bidder shall be obliged to submit the same.

On completion of the above stated registration process, a bidder shall be able to login to MSTC's website.

<b>ANNEXURE B</b>
Draft Pre-Award Integrity Pact

**GENERAL**

This pre-bid contract Agreement (herein after called the Integrity Pact) is made on ..... day of the month of ..... 20....., between, on one hand, ..... [Insert name of BPC] through Shri ..... [Insert Name & designation of representative of BPC] (hereinafter called the "Bid Process Coordinator/ BPC", which expression shall mean and include, unless the context otherwise requires, his successors in the office and assigns) of the First Part and M/s ..... represented by Shri ..... [Insert Name & Designation of Authorized Signatory of the Bidder/ Lead Member of Consortium] (hereinafter called the "Bidder" which expression shall mean and include, unless the context otherwise requires, his successors and permitted assigns) of the Second Part.

WHEREAS the BPC is conducting the bidding process for selection of bidder as Transmission Service Provider (TSP) for “**Augmentation at Bhadla-III, Ramgarh PS and Kanpur (PG)**” who will be responsible to set up the transmission project on build, own, operate and transfer (BOOT) basis and to provide Transmission Service.

WHEREAS the Bidder is a Private Company/Public Company/Government Undertaking/ Partnership, constituted in accordance with the relevant law in the matter and the BPC is a Public Sector Undertaking (PSU) performing its function on behalf of the Ministry of Power, Government of India.

NOW, THEREFORE,

To avoid all forms of corruption by following a system that is fair, transparent and free from any influence/prejudiced dealings during the complete bidding process with a view to:-

Enabling the BPC to select the bidder as TSP in conformity with the defined procedures by avoiding the high cost and the distortionary impact of corruption on public procurement, and

Enabling Bidder to abstain from bribing or indulging in any corrupt practice in order to emerge as selected bidder by providing assurance to them that their competitors will also abstain from bribing and other practices and the BPC will commit to prevent corruption, in any form, by its officials by following transparent procedures.

The parties hereto hereby agree to enter into this Integrity Pact and agree as follows:

**Commitments of BPC**

1.1 The BPC undertakes that no official of the BPC, connected directly or indirectly with

the bidding process, will demand, take a promise for or accept, directly or through intermediaries, any bribe, consideration, gift, reward, favour or any material or immaterial benefit or any other advantage from the BIDDER, either for themselves or for any person, organization or third party related to the bidding process in exchange for an advantage in the bidding process, bid evaluation, contracting or implementation process related to the contract.

- 12 The BPC will, during the bidding stage, treat all bidders alike, and will provide to all bidders the same information and will not provide any such information to any particular bidder which could afford an advantage to that particular bidder in comparison to the other bidders.
- 13 All the officials of the BPC will report the appropriate Government office any attempted or completed breaches of the above commitments as well as any substantial suspicion of such a breach.
- 2 In case of any such preceding misconduct on the part of such official(s) is reported by the Bidder to the BPC with the full and verifiable facts and the same is *prima facie* found to be correct by the BPC, necessary disciplinary proceedings, or any other action as deemed fit, including criminal proceedings may be initiated by the BPC and such a person shall be debarred from further dealings related to the bidding process. In such a case while an enquiry is being conducted by the BPC the proceedings under the bidding process would not be stalled.

### **Commitments of Bidder**

3. The Bidder commits itself to take all measures necessary to prevent corrupt practices, unfair means and illegal activities during any stage of its bid or during any pre award stage in order to emerge as Selected Bidder or in furtherance to secure it and in particular commits itself to the following:-
  - 3.1 The Bidder will not offer, directly or through intermediaries, any bribe, gift, consideration, reward, favour, any material or immaterial benefit or other advantage, commission, fees, brokerage or inducement to any official of the BPC, connected directly or indirectly with the bidding process, or to any person, organization or third party related to the bidding process in exchange for any advantage in the bidding, evaluation, contracting and implementation of the bidding process.
  - 3.2 The Bidder further undertakes that it has not given, offered or promised to give, directly or indirectly any bribe, gift, consideration, reward, favour, any material or immaterial benefit or other advantage, commission, fees, brokerage or inducement to any official of the BPC or otherwise in bidding process or for bearing to do or having done any act in relation to bidding process or any other contract with the Government for showing or forbearing to show favour or disfavour to any person in relation to the bidding process or any other contract with the Government.

- 33 The Bidder shall disclose the name and address of agents and representatives and Indian Bidder shall disclose their foreign principals or associates.
- 34 The Bidder shall disclose the payments to be made by them to agents/brokers or any other intermediary, in connection with this bid .
- 35 The Bidder further confirms and declares to the BPC that the Bidder has not engaged any individual or firm or company whether Indian or foreign to intercede, facilitate or in any way to recommend to the BPC or any of its functionaries, whether officially or unofficially for selection of Bidder as TSP, nor has any amount been paid, promised or intended to be paid to any such individual, firm or company in respect of any such intercession, facilitation or recommendation.
- 36 The Bidder, either while presenting the bid or during pre-award negotiations or before signing the Share Purchase Agreement, shall disclose any payments he has made, is committed to or intends to make to officials of the BPC or their family members, agents, brokers or any other intermediaries in connection with the bidding process and the details of services agreed upon for such payments.
- 3.7 The Bidder will not collude with other parties interested in the bidding process to impair the transparency, fairness and progress of the bidding process.
- 38 The Bidder will not accept any advantage in exchange for any corrupt practice, unfair means and illegal activities.
- 39 The Bidder shall not use improperly, for purpose of competition or personal gain, or pass on to others, any information provided by the BPC as part of the business relationship, regarding plans, technical proposal and business details, including information contained in any electronic data carrier. The Bidder also undertakes to exercise due and adequate care lest any such information is divulged.
- 3.10 The Bidder commits to refrain from giving any complaint directly or through any other manner without supporting it with full and verifiable facts.
- 3.11 The Bidder shall not instigate or cause to instigate any third person to commit any of the actions mentioned above.
- 3.12 The Bidder shall not lend to or borrow any money from or enter into any monetary dealings or transactions, directly or indirectly, with any employee of the BPC.
- 4 Previous Transgression**
- 4.1 The Bidder declares that no previous transgression occurred in the last three years immediately before signing of this Integrity Pact, with any other company in any

country in respect of any corrupt practices envisaged hereunder or with any Public Sector Enterprise in India or any Government Department in India that could justify Bidder's exclusion from the bidding process.

- 42 The Bidder agrees that if it makes incorrect statement on this subject, Bidder can be disqualified from the tender process or the contract, if already awarded, can be terminated for such reason.

## 5. Bid Bond (Security Deposit)

- 5.1 Along with the technical bid, the Bidder shall submit Bid Bond for an amount of Rs. .... (as per the amount specified in Request for Proposal (RFP) Document) issued by ..... [Insert Name of the Banks from the list provided in RFP Document] as Earnest Money/Security Deposit, with the BPC.

- 5.2 The Earnest Money/Security Deposit shall be valid & retained by the BPC for such period as specified in the RFP Document.

- 5.3 No interest shall be payable by the BPC to the Bidder on Earnest Money/Security Deposit for the period of its currency.

## 6. Sanctions for Violations

- 6.1 Any breach of the aforesaid provisions by the Bidder or any one employed by it or acting on its behalf (whether with or without the knowledge of the Bidder) shall entitle the BPC to take all or anyone of the following actions, wherever required:-

- (i) To immediately call off the pre-award negotiations without assigning any reason or giving any compensation to the Bidder. However, the proceedings with the other Bidder (s) would continue.
- (ii) The Bid Bond (in pre-award stage) shall stand forfeited either fully or partially, as decided by the BPC and the BPC shall not be required to assign any reason therefore.
- (iii) To immediately cancel the award, if already awarded, without giving any compensation to the Bidder.
- (iv) To cancel all or any other contracts with the Bidder. The Bidder shall be liable to pay compensation for any loss or damage to the BPC resulting from such cancellation/rescission.
- (v) To debar the Bidder from participation in any tender or RFP issued by any BPC for an indefinite period.

(vi) To recover all sums paid in violation of this Pact by Bidder to any middleman or agent or broker with a view to securing the award.

62 The BPC will be entitled to take all or any of the actions mentioned at para 6.1 (i) to (vi) of this Pact also on the Commission by the Bidder or anyone employed by it or acting on its behalf (whether with or without the knowledge of the Bidder), of an offence as defined in Chapter IX of the Indian Penal code, 1860 or Prevention of Corruption Act, 1988 or any other statute enacted for prevention of corruption.

63 The decision of the BPC to the effect that a breach of the provisions of this Pact has been committed by the Bidder shall be final and conclusive on the Bidder. However, the Bidder can approach the Independent Monitor(s) appointed for the purposes of this Pact.

## **7. Independent Monitors**

7.1 The BPC has appointed Independent Monitors (hereinafter referred to as Monitors) for this Pact in consultation with the Central Vigilance Commission (Names and Addresses of the Monitors to be given).

7.2 The task of the Monitors shall be to review independently and objectively, whether and to what extent the parties comply with the obligations under this Pact.

7.3 The Monitors shall not be subject to instructions by the representatives of the parties and perform their functions neutrally and independently.

7.4 Both the parties accept that the Monitors have the right to access all the documents relating to the project/procurement, including minutes of meetings.

7.5 As soon as the Monitor notices, or has reason to believe, a violation of this Pact, he will so inform the Authority designated by the BPC.

7.6 The Bidder accepts that the Monitors has the right to access without restriction to all Project documentation of the BPC including that provided by the Bidder. The Monitor shall be under contractual obligation to treat the information and documents of the Bidder /Subcontractors(s) with confidentially. [As all the bid documents are with BPC only]

7.7 The BPC will provide to the Monitors sufficient information about all meetings among the parties related to the Project provided such meetings could have an impact on the contractual relations between the parties. The parties will offer to the monitor the option to participate in such meetings.

7.8 The Monitor will submit a written report to the designated Authority of the BPC/Secretary in the Department within 8 to 10 weeks from the date of reference or

intimation to him by the BPC / Bidder and, should the occasion arise, submit proposals for correcting problematic situations.

#### **8 Facilitation of Investigation**

In case of any allegation of violation of any provisions of this Pact or payment of commission, the BPC or its agencies shall be entitled to examine all the documents including the Books of Accounts of the Bidder and the Bidder shall provide necessary information and documents in English and shall extend all possible help for the purpose of such examination.

#### **9 Law and Place of Jurisdiction**

This Pact is subject to Indian Law. The place of performance and jurisdiction is the seat of the BPC.

#### **10 Other Legal Actions**

The actions stipulated in this Integrity Pact are without prejudice to any other legal action that may follow in accordance with the provisions of the any extent law in force relating to any civil or criminal proceedings.

#### **11 Validity**

11.1 The validity of this Integrity Pact shall be from date of its signing and upto 6 months from the date of transfer of project specific SPV i.e. signing of Share Purchase Agreement with BPC. In case Bidder is unsuccessful, this Integrity Pact shall expire after 15 days from the date of transfer of project specific SPV to successful bidder.

11.2 Should one or several provisions of this Pact turn out to be invalid, the remainder of this Pact shall remain valid. In this case, the parties will strive to come to an agreement to their original intentions.

12. The Parties hereby sign this Integrity Pact at \_\_\_\_\_ on \_\_\_\_\_

<p>Bid Process Coordinator (BPC)</p> <p>Name of the Officer Designation Name of the BPC with address</p> <p>Witness:</p> <p>1. _____</p> <p>2. _____</p>	<p>BIDDER</p> <p>Name of Whole time Director/Authorized Signatory Name of the Bidder with address</p> <p>Witness:</p> <p>1. _____</p> <p>2. _____</p>
--	---

## ANNEXURE C

### Technical Specifications of Transmission System

#### SPECIFIC TECHNICAL REQUIREMENTS FOR SUBSTATION

Extension of 765/400/220 kV Bhadla-III PS shall be conventional Air Insulated Substation (AIS) type (Bay of 10<sup>th</sup> ICT on 220 kV side shall be GIS) generally conforming to the requirements of CEA (Technical Standards for Construction of Electrical Plants and Electric Lines) Regulations 2022, as amended from time to time.

Extension of 765/400/220 kV Ramgarh PS shall be conventional Air Insulated Substation (AIS) type generally conforming to the requirements of CEA (Technical Standards for Construction of Electrical Plants and Electric Lines) Regulations 2022, as amended from time to time.

Extension of 765/400 kV Kanpur (PG) S/s shall be Gas Insulated Substation (GIS) type generally conforming to the requirements of CEA (Technical Standards for Construction of Electrical Plants and Electric Lines) Regulations 2022, as amended from time to time.

Other CEA Regulations/guidelines as amended up to date and MoP guidelines, as applicable, shall also be followed.

#### **B.1.0 Salient features of Substation Equipment and Facilities**

The design and specification of substation equipment are to be governed by the following factors:

#### **B.1.1 Insulation Coordination**

The system design parameters for substations/switchyards shall be as given below:

Sl. No	Description of parameters	Extn. of 765/400/220 kV Ramgarh PS		
		765 kV System	400 kV System	220 kV System
1.	System Operating Voltage	765 kV	400 kV	220 kV
2.	Maximum voltage of the system (rms)	800 kV	420 kV	245 kV
3.	Rated Frequency	50 Hz	50 Hz	50 Hz
4.	No. of Phases	3	3	3
5.	Rated Insulation Levels			
i)	Lightening Impulse withstand voltage for (1.2/50 micro sec.)			
	- for Equipment other than Transformer and Reactor	2100 kVp	1425 kVp	1050 kVp
	- for Insulator String	2100 kVp	1550 kVp	1050 kVp

Sl. No	Description of parameters	Extn. of 765/400/220 kV Ramgarh PS		
		765 kV System	400 kV System	220 kV System
ii)	Switching Impulse withstand voltage (250/2500 micro sec.) dry and wet	1550 kVp	1050 kVp	-
iii)	One minute power frequency dry withstand voltage (rms)	830 kV	630 kV	-
iv)	One minute power frequency dry and wet withstand voltage (rms)		-	460 kV
6.	Corona Extinction Voltage	508 kV	320 kV	-
7.	Max. radio interference voltage for frequency between 0.5 MHz and 2 MHz	2500 micro-volts at 508 kV rms	1000 micro-volts at 266 kVrms	1000 micro-volts at 156 kVrms
8.	Minimum creepage distance for insulator string/ longrod insulators/ outdoor bushings	24800 mm (31mm/kV)	13020 mm (31 mm/kV)	7595 mm (31 mm/kV)
9.	Minimum creepage distance for switchgear equipment	20000 mm (25 mm/kV)	10500 mm (25 mm/kV)	6125 mm (25 mm/kV)
10.	Max. fault current	50 kA	63 kA	50 kA
11.	Duration of Fault	1 sec	1 sec	1 sec

Sl. No	Description of parameters	Extn. of 765/400/220 kV Bhadla-III PS		Extn. of 765/400 kV Kanpur (PG) S/s	
		400 kV System	220 kV System	765 kV System	400 kV System
1.	System Operating Voltage	400 kV	220 kV	765 kV	400 kV
2.	Maximum voltage of the system (rms)	420 kV	245 kV	800 kV	420 kV
3.	Rated Frequency	50 Hz	50 Hz	50 Hz	50 Hz
4.	No. of Phases	3	3	3	3
5.	Rated Insulation Levels				
i)	Lightening Impulse withstand voltage for (1.2/50 micro sec.) - for Equipment other than Transformer and Reactor - for Insulator String	1425 kVp 1550 kVp	1050 kVp 1050 kVp	2100 kVp 2100 kVp	1425kVp 1550 kVp
ii)	Switching Impulse withstand voltage (250/2500 micro sec.) dry and wet	1050 kVp	-	1550 kVp/ 1425 kVp for GIS	1050 kVp

Sl. No	Description of parameters	Extn. of 765/400/220 kV Bhadla-III PS		Extn. of 765/400 kV Kanpur (PG) S/s	
		400 kV System	220 kV System	765 kV System	400 kV System
iii)	One minute power frequency dry withstand voltage (rms)	630 kV	-	830 kV (AIS)/ 960 kV (GIS)	630 kV (AIS)/ 650 kV (GIS)
iv)	One minute power frequency dry and wet withstand voltage (rms)	-	460 kV		-
6.	Corona Extinction Voltage	320 kV	-	508 kV	320 kV
7.	Max. radio interference voltage for frequency between 0.5 MHz and 2 MHz	1000 micro-volts at 266kVrms	1000 micro-volts at 156 kV rms	2500 micro-volts at 508 kV rms	1000 micro-volts at 266 kV rms
8.	Minimum creepage distance for insulator string/ longrod insulators/ outdoor bushings	13020 mm (31 mm/kV)	7595 mm (31 mm/kV)	24800 mm (31 mm/kV)	13020 mm (31 mm/kV)
9.	Minimum creepage distance for switchyard equipment	10500 mm (25 mm/kV)	6125 mm (25 mm/kV)	20000 mm (25 mm/kV)	10500 mm (25 mm/kV)
10.	Max. Fault Current	63 kA	50 kA	50 kA	63 kA
11.	Duration of Fault	1 sec	1 Sec	1 sec	1 sec

### B.1.2 Switching Scheme

The switching schemes, as mentioned below, shall be adopted at various voltage levels of substation/switchyard:

Substation	765 kV side	400 kV side	220 kV side
Extn. of 765/400/220 kV Bhadla-III PS	One and Half breaker	One and Half breaker	Double Main and Transfer (AIS)/ Double Main (GIS extn.)
Extn. of 765/400/220 kV Ramgarh PS	One and Half breaker	One and Half breaker	Double Main and Transfer
Extn. of 765/400 kV Kanpur (PG) S/s	One and Half breaker	One and Half breaker	-NA-

**Notes: -**

- Two transformers of same HV rating shall not be connected in the same diameter and similarly two bus reactors of same HV rating shall also not be connected in the same

diameter.

- ii) *A diameter in one and half breaker scheme is a set of 3 circuit breakers with associated isolators, earth switches, current transformers etc. for controlling 2(two) numbers of feeders.*
- iii) *In case of GIS substation where the bus scheme is One & Half breaker scheme, the diameters shall be complete with feeder/line side isolator to be used for any future line bay and GIS duct of the future bay shall be brought outside the GIS hall/building with extension/interface module suitably.*
- iv) *TSP shall plan distribution of line and transformer feeders to bus bar in such a way that all power can be evacuated successfully without crossing thermal limit at any point of bus bar.*

v) **Extension of Bhadla-III PS:**

- (a) 5 Nos. of 220 kV line bays (Bay No. – 218, 220, 226, 227 & 231) shall be constructed under present scope at Bhadla-III PS at 220 kV level.*
- (b) 1 No. of 400 kV line bay shall be terminated in the new diameter at Bhadla-III PS. Accordingly, one no. Main Bay and associated Tie Bay (430- Main Bay & 431- Tie Bay) shall be constructed under present scope at Bhadla-III PS.*
- (c) TSP shall also construct 02 sets of bus sectionalizer at 400 kV level (set-1: Bay No. 419 & 420, set-2: Bay No. 442 & 443)*

**400/220 kV for ICT Termination:**

- (d) Four Nos. (out of 5 Nos.) 500 MVA ICTs shall be terminated at the 220 kV bus Section-2 in AIS arrangement. In addition, one number of 500 MVA ICTs shall be connected at the 220 kV bus Section-1 through GIS/cable arrangement alongwith associated indoor/outdoor GIS bay under the present scope of work.*
- (e) Single Line Diagram (Drg. No. C/ENGG/SS/BHADLA-3/SLD, Rev. No.-00) of Bhadla-III substation attached with the RfP shall be referred in this regard.*
- (f) Further, all associated interconnection work shall also be in the present scope of TSP.*

vi) **Extension of Ramgarh PS:**

- (a) For Augmentation of 765/400 kV, 2x1500 MVA (3rd & 4th) ICTs, both ICT shall be installed in two number new diameters at Ramgarh PS. Accordingly, 2 Nos. Main Bay and associated Tie Bay (712- Main Bay & 711- Tie Bay and 715- Main Bay & 714- Tie Bay) shall be constructed under present scope at Ramgarh PS at 765 kV level and 02 Nos. Main Bay and associated Tie Bay (421- Main Bay & 422-*

*Tie Bay and 424- Main Bay & 425- Tie Bay) shall be constructed under present scope at Ramgarh PS at 400 kV level.*

- (b) *For Augmentation of 400/220 kV, 2x500 MVA (3rd & 4th) ICTs, 2 numbers Main Bays (Main Bay 423 & Main Bay 426) shall be constructed under present scope at Ramgarh PS at 400 kV level.*
- (c) *2 numbers of 220 kV line bays (Bay No. – 207 & 208) shall be constructed under present scope at Ramgarh PS.*
- (d) *1 number of 400 kV line bay (Main Bay No. – 406) shall be constructed in the existing diameter at Ramgarh PS.*
- (e) *Single Line Diagram (Drg. No. C/ENGG/SS/RAMGARH PS/SLD ) of Ramgarh PS substation attached with the RfP shall be referred in this regard.*
- (f) *Further, all associated interconnection work shall also be in the present scope of TSP.*

vii) **Extension of Kanpur (PG) S/s:**

- (a) *For Augmentation of 765/400 kV, 1x1500 MVA (3rd) ICT shall be terminated in new diameter at 765 kV voltage level and in the existing bay at 400 kV voltage level. Accordingly, 2 numbers main bays (1 for ICT termination & 1 for diameter completion) and associated Tie bay shall be constructed at 765 kV level under present scope at Kanpur (PG) S/s.*
- (b) *Single Line Diagram (Drg. No.- PG/PGCIL/KNP/Sl-drg/001,Rev. No.-R4) of Kanpur substation attached with the RfP shall be referred in this regard.*
- (c) *Further, all associated interconnection work including surge arrester for 400kV side of ICT shall also be in the present scope of TSP.*

B.2.0 Substation Equipment and facilities (Voltage level as applicable):

The switchgear shall be designed and specified to withstand operating conditions and duty requirements. All equipment shall be designed considering the following capacity.

Sl. No	Description of bay	Extn. of 765/400/220 kV Ramgarh PS		
		765 kV	400 kV	220 kV
1.	Bus Bar	As per existing	As per existing	As per existing

Sl. No	Description of bay	Extn. of 765/400/220 kV Ramgarh PS		
		765 kV	400 kV	220 kV
2.	Line bay	--	3150 A	1600 A
3.	ICT bay	3150 A	3150 A	1600 A

Sl. No	Description of bay	Extn. of 765/400/220 kV Bhadla-III PS		Extn. of 765/400 kV Kanpur (PG) S/s	
		400 kV	220 kV	765 kV	400 kV
1.	Bus Bar	As per existing	As per existing	As per existing	As per existing
2.	Line bay	3150 A	1600 A	--	--
3.	ICT bay	3150 A	1600 A	3150 A	As per existing
4.	Bus Sectionalizer Bay	4000 A	--	--	--

#### B.2.1 (765/√3)/ (400/√3)/ 33 kV, Single Phase Autotransformer

500 MVA, (765/√3)/ (400/√3)/ 33 kV, 1-phase Autotransformer (including arrangement for 3-phase bank formation of 1500 MVA) shall conform to CEA's "Standard Specifications and Technical Parameters for Transformers and Reactors (66 kV and above Voltage Class)" as amended up to date available on CEA's website.

Connection arrangement for utilization of existing Spare Single Phase Transformer unit: TSP shall make the arrangement of present Transformer bank in such a way that the existing spare unit can be utilized for Transformer bank under present scope without its physical movement.

#### B.2.2 400/220 kV, 3-phase Autotransformer

500 MVA, 400/220 kV, 3-phase Autotransformer shall conform to CEA's "Standard Specifications and Technical Parameters for Transformers and Reactors (66 kV and above Voltage Class)" as amended up to date available on CEA's website.

#### B.2.3 765 kV & 220 kV GIS equipment (as applicable)

GIS (Gas Insulated Substation) shall be Indoor type in accordance to IEC: 62271-203. The switchgear shall be designed and specified to withstand operating conditions and duty requirements. All the switchgear such as Circuit Breaker, isolator, earth switch including CT, PT etc. shall be GIS type. The Surge Arrestor and Voltage Transformer shall be either GIS or outdoor AIS type.

The GIS assembly shall consist of separate modular compartments e.g. Circuit Breaker compartment, Bus bar compartment filled with SF6 Gas and separated by gas tight partitions so as to minimize risk to human life, allow ease of maintenance and limit the effects of gas leaks failures & internal arcs etc. These compartments shall be designed to minimize the risk of damage to adjacent sections and protection of personnel in the event of a failure occurring within the compartments. Rupture diaphragms with suitable deflectors shall be provided to prevent uncontrolled bursting pressures developing within the enclosures under worst operating conditions, thus providing controlled pressure relief in the affected compartment. The arrangement of gas sections or compartments shall be such as to facilitate future extension of any make without any drilling, cutting or welding on the existing equipment. To add equipment, it shall not be necessary to move or dislocate the existing switchgear bays. The layout of Gas Insulated Bus Ducts shall be properly planned to optimize the length of bus ducts and for easy accessibility for maintenance. The length of busbars, bus ducts, isolator sections shall be optimized considering effects of fast transient voltage due to isolator operations.

The bus bar modules including auxiliary bus modules (wherever applicable) shall be provided with suitable End Piece (Interface) module on both sides with the test link facility for future extension as per provisions of future requirements. The end piece module shall be designed in such a way so that future GIS modules may be tested without extending test voltage to existing bus and vice-versa by removing the test link.

TSP shall make available the complete details for the design of interface module such as cross section, enclosure material, enclosure dimensions (inner and outer), Flange diameter (inner and outer), conductor cross-section and connection arrangement, bolt spacing & dimension, rated gas pressure, Gasket detail etc. Further, adequate space for GIS busbar interface module shall be taken into account for future scope.

Each section shall have plug-in or easily removable connection pieces to allow for easy replacement of any component with the minimum disturbance to the remainder of the equipment. Inspection windows (View Ports) shall be provided for Disconnecter Switches and both type of earth switches i.e. Maintenance and fast operating.

Local Control Cabinets (LCC) shall be provided as per requirement. The alarm & annunciation of GIS equipment shall be wired to the SCADA System.

The material and thickness of the enclosures shall be such as to withstand an internal flashover without burns through for a period of 300 ms at rated short time withstand current. The material shall be such that it has no effect of environment as well as from the by-products of SF6 breakdown under arcing conditions. This shall be validated with Type Test.

**Service continuity requirement for GIS:**

The GIS equipment with the given bus switching arrangement shall be divided into different gas compartments. During the work such as a fault repair or major maintenance, requiring the dismantling of a gas compartment for which more than one compartments may need to be de-gassed.

TSP shall meet following Service continuity conditions (to the extent possible) with ensuring equipment and operating personnel's safety:

- For One & half breaker bus switching scheme, during a fault in Circuit Breaker compartment, no bus bar and feeder is permitted out of service during maintenance and repair/replacement.
- For Double Main bus switching scheme, during a fault in Circuit Breaker compartment, no bus bar is permitted out of service during maintenance and repair/replacement.
- During a fault in a GIS compartment other than the Circuit Breaker compartment, maximum of one bus bar and/or one feeder is permitted out of service during maintenance and repair/replacement.

**UHF sensors in GIS for PD (Partial Discharge) detection:**

The adequate number of Ultra High Frequency (UHF) sensors shall be provided in the offered GIS along with suitable portable type Partial Discharge (PD) measuring instrument for detection of Partial discharge (of 5 pC and above as per IEC 60270). The number and location of these sensors shall be based on laboratory tests on the typical design of GIS as per recommendations of CIGRE Document No. 654 (Application Guide for sensitivity verification for UHF Partial discharge detection system for GIS).

**B.2.3.1 Circuit Breakers (GIS)**

GIS Circuit breakers shall in general be of C2-M2 class and comply with IEC-62271-100. The rated break time shall not exceed 40 ms for 765 kV and 60 ms for 220 kV. Circuit breakers shall be provided with single phase and three phase auto reclosing. Each breaker would have two sets of trip circuits which would be connected to separate DC supplies for greater reliability. The Circuit breakers controlling 765 kV lines wherever required shall be provided with pre-insertion closing resistor of about 400 ohms with 8 ms insertion time or Controlled Switching Device (CSD) for lines longer than 200 km. The short line fault capacity shall be the same as the rated capacity and this is proposed to be achieved without use of opening resistors. Control Switching Device shall be provided in the Circuit Breaker of switchable line reactor bay and in Main & Tie bay circuit breakers of line with non-switchable line reactors, Bus reactors & Transformer of 400 kV and above voltage class.

### **B.2.3.2 Isolators (GIS)**

The isolators shall comply with IEC 62271-102 in general. Earth switches shall be provided at various locations to facilitate maintenance. Main blades and earth blades shall be interlocked, and interlock shall be fail safe type. All isolators and earth switches shall be motor operated type.

The isolator shall be of extended mechanical endurance class-M2 and suitable for Bus Transfer Current Switching duty as per IEC standards. High speed earthing switches shall be provided for grounding purposes at overhead line terminations & cable terminations and shall have fault making capability as specified. Earth switch for line isolator shall be of earthing switch class E1 and shall be suitable for induced current switching duty as defined for Class-B as per relevant standard.

### **B.2.3.3 Current Transformers (GIS)**

Current Transformers shall comply with IEC 61869 in general. All ratios shall be obtained by secondary taps only. For 400 kV and above voltage class, generally Current Transformers (CT) shall have five cores (four for protection and one for metering) whereas CT in Tie bays shall have six cores (four for protections & two for metering) suitably distributed on both sides of CB. 220 kV Current Transformers (CT) shall have five cores (four for protection and one for metering). The burden and knee point voltage shall be in accordance with the requirements of the system including possible feeds for telemetry. The accuracy class for protection core shall be PX and for metering core it shall be 0.2S. The rated burden of cores shall be closer to the maximum burden requirement of metering and protection system (not more than 20 VA for metering core) for better sensitivity and accuracy.

The instrument security factor shall be less than 5 for CTs up to 400 kV voltage class and less than 10 for CTs of 765 kV voltage class.

### **B.2.3.4 Voltage Transformers (GIS)**

The voltage transformers shall conform to IEC-61869. Voltage transformers shall be of electromagnetic type with SF6 gas insulation. The earth end of the high voltage winding and the ends of the secondary winding shall be brought out in the terminal box. The voltage transformers shall be located as a separate bay module and will be connected phase to ground and shall be used for protection, metering and synchronization. The voltage transformers shall be of inductive type, nonresistant and shall be contained in their own-SF6 compartment, separated from other parts of installation. The voltage transformer shall be effectively shielded against high frequency electromagnetic transients. The voltage transformer shall have three secondary windings out of which two shall be used for protection and one for metering. The voltage transformer should be thermally and dielectrically safe when the secondary terminals are loaded with the guaranteed thermal burdens. The accuracy

class for protection cores shall be 3P. The accuracy of 0.2 on metering core should be maintained throughout the entire burden range on all the three windings without any adjustments during operation. The rated burden of cores shall be closer to the maximum burden requirement of metering and protection system (not more than 50 VA for metering core) for better sensitivity and accuracy.

#### **B.2.3.5 Surge Arresters (GIS)**

624 kV, 336kV Station High (SH) duty & 216kV Station Medium (SM) duty gapless type Surge arresters with thermal energy (Wth) of minimum 13 kJ/kV, 12 kJ/kV & 7 kJ/kV conforming to IEC 60099-4 in general shall be provided for 800 kV, 420 kV & 245 kV systems respectively. Other characteristics of Surge arrester shall be chosen in accordance with system requirements. Surge arresters shall be provided at line entrance near Transformers & Reactor so as to achieve proper insulation coordination. Surge Arresters shall be provided with porcelain/ polymer housing fitted with pressure relief devices. A leakage current monitor with surge counter shall be provided with each surge arrester.

#### **B.2.3.6 SF<sub>6</sub> to Air Bushing**

Outdoor bushings, for the connection of conventional external conductors to the SF<sub>6</sub> metal enclosed switchgear, shall be provided. Bushings shall generally be in accordance with the requirements of IEC-60137. The creepage distance over the external surface of outdoor bushings shall not be less than 31 mm/kV. SF<sub>6</sub> to air Bushing shall be of Polymer / composite type and shall be robust and designed for adequate cantilever strength to meet the requirement of seismic conditions. The electrical and mechanical characteristics of bushings shall be in accordance with IEC 60137. Polymer/composite insulator shall be seamless sheath of silicon rubber compound. The housing and weather sheds should have silicon content of minimum 30% by weight. It should protect the bushing against environmental influences, external pollution and humidity. The hollow silicon composite insulators shall comply with the requirements of IEC 61462 and the relevant parts of IEC 62217.

#### **B.2.4 765 kV, 400 kV & 200 kV AIS equipment (as applicable)**

##### **B.2.4.1 Circuit Breakers (AIS)**

The circuit breakers and accessories shall conform to IEC: 62271-100, IEC: 62271-1 and shall be of SF<sub>6</sub> Type. The circuit breakers shall be of class C2-M2 (as per IEC) with regard to restrike probability during capacitive current breaking and mechanical endurance. The rated break time shall not exceed 40 ms for 765 kV and 400 kV circuit breakers and 60 ms for 220 kV circuit breakers. The 765 kV, 400 kV and 220 kV Circuit breakers shall be provided with single phase and three phase auto reclosing. Each breaker would have two sets of trip circuits which would be connected to separate DC supplies for greater reliability. The circuit breakers controlling 765 kV lines shall be

provided with either pre-insertion closing resistor of about 450 ohm maximum with 9 ms insertion time or with Controlled Switching Device (CSD). The Circuit breakers controlling 400 kV lines shall be provided with either pre insertion closing resistor of about 400 ohm with 8 ms insertion time or with Controlled Switching Device (CSD) for lines longer than 200 km length. The short line fault capacity shall be same as the rated capacity and this is proposed to be achieved without use of opening resistors. The Controlled Switching Device shall be provided in circuit breakers of switchable line reactor bay and in Main and Tie bay circuit breakers of line with non-switchable line reactors, Bus Reactors and Transformers of 400 kV and above voltage class.

#### **B.2.4.2 Isolators (AIS)**

The Isolators shall comply with IEC 62271-102 in general. 765 kV Isolator design shall be double break or vertical break or knee-type. 400 kV and 220 kV Isolators shall be double break type. All Isolators and earth switches shall be motor operated. Earth switches shall be provided at various locations to facilitate maintenance. Isolator rated for 400 kV and 220 kV shall be of extended mechanical endurance class - M2 as per IEC-62271-102. Isolator rated for 220 kV shall be suitable for bus transfer current switching duty as per IEC-62271-102. Main blades and earth blades shall be interlocked, and interlock shall be fail safe type. The 765 kV, 400 kV and 220 kV earth switch for line isolator shall be suitable for induced current switching duty as defined for Class-B.

#### **B.2.4.3 Current Transformers (AIS)**

Current Transformers shall comply with IEC 61869 in general. All ratios shall be obtained by secondary taps only. Generally, Current Transformers (CT) for 765 kV and 400 kV shall have six cores (four for protection and two for metering) and 220 kV Current Transformers shall have five cores (four for protection and one for metering). The burden and knee point voltage shall be in accordance with the requirements of the system including possible feeds for telemetry. The accuracy class for the protection core shall be PX and for the metering core it shall be 0.2S. The rated burden of cores shall be closer to the maximum burden requirement of the metering and protection system (not more than 20 VA for metering core) for better sensitivity and accuracy. The instrument security factor shall be less than five (5) for CTs up to 400 kV and less than ten (10) for CTs of 765 kV voltage class.

#### **B.2.4.4 Capacitive Voltage Transformers (AIS)**

Capacitive Voltage Transformers shall comply with IEC 61869 in general. These shall have three secondaries out of which two shall be used for protection and one for metering. The accuracy class for protection cores shall be 3P and for metering core shall be 0.2. The Capacitive Voltage Transformers on lines shall be suitable for Carrier Coupling. The Capacitance of CVT for 400 kV and 220 kV shall be of 4400/8800 pF depending on PLCC requirements whereas the Capacitance of CVT for 765 kV shall be 8800 pF. The rated burden of cores shall be closer to the maximum burden

requirement of metering and protection system (not more than 50 VA for metering core) for better sensitivity and accuracy.

#### **B.2.4.5 Surge Arresters (AIS)**

624 kV, 336 kV Station High (SH) duty and 216 kV Station Medium (SM) duty gapless type Surge Arresters with thermal energy (Wth) of minimum 13 kJ/kV, 12 kJ/kV and 7 kJ/kV conforming to IEC 60099-4 in general shall be provided for 800 kV, 420 kV and 245 kV systems respectively. Other characteristics of Surge Arrester shall be chosen in accordance with system requirements. Surge Arresters shall be provided at line entrances, near Transformers and Reactor so as to achieve proper insulation coordination. Surge Arresters shall be provided with porcelain/ polymer housing fitted with pressure relief devices. A leakage current monitor with surge counter shall be provided with each surge arrester.

#### **B.2.5 Protection Relaying and Control System**

The protective relaying system proposed to be provided for transmission lines, auto-transformers, reactors and bus bars to minimize the damage to the equipment in the events of faults and abnormal conditions, is dealt in this section. All main protective relays shall be numerical type with IEC 61850 communication interface and should have interoperability during integration of numerical relays to communicate over IEC 61850 protocol with RTU/SAS/IEDs of different OEMs. All numerical relays shall have built in disturbance recording feature.

The protection circuits and relays of the transformer and reactor shall be electrically and physically segregated into two groups each being independent and capable of providing uninterrupted protection even in the event of one of the protection groups failing, to obtain redundancy, and to take protection systems out for maintenance while the equipment remains in service.

##### **a) Transmission Lines Protection**

765 kV, 400 kV and 220 kV lines shall have Main-I numerical three zone distance protection scheme with carrier aided inter-tripping feature. 765 kV, 400 kV and 220 kV lines shall also have Main-II numerical distance protection scheme like Main-I but from different make that of Main-I. The Main-I and Main-II protection relays of same make may be provided only if they are of different hardware and manufacturing platform or different principle of operation.

However, Line Current Differential Relay (with back up distance protection feature) as Main-I and Main-II shall be considered at both ends for short lines (line length below 30 km) having Fiber Optic Communication Link. Differential relay at remote end shall be provided by the TSP. The associated power and control cabling and integration with SAS at remote end shall be provided by respective bay owners.

In case of 220 kV line bays for RE Generators, Line Current differential relay (with back up distance protection feature) as Main-I and Main-II shall be provided. Further,

in such cases, the matching line current differential relay for remote end shall be provided by the TSP as loose supply. Further, all 765 kV, 400 kV and 220 kV lines shall be provided with single and three phase auto-reclosing facility to allow reclosing of circuit breakers in case of transient faults. These lines shall also be provided with distance to fault locators to identify the location of fault on transmission lines.

All 765 kV and 400 kV lines shall also be provided with two stage over voltage protection. The over voltage protection and distance to fault locator may be provided as in-built feature of Main-I and Main-II protection relays.

Auto reclose as built-in function of Bay Control Unit (BCU) is also acceptable.

The Main-I and Main-II protection relays shall be fed from separate DC sources and shall be mounted in separate panels.

For 765 kV, 400 kV and 220 kV transmission lines, directional IDMT earth fault relay should be provided as standalone unit or in-built feature of Main-I and Main -II feature.

#### **b) Auto Transformer Protection**

These shall have the following protections:

- i) Numerical Differential Protection
- ii) Numerical Restricted Earth Fault Protection
- iii) Numerical Back-up Over-Current and Earth Fault Protection on High Voltage (HV) and Intermediate Voltage (IV) side
- iv) Numerical Over Fluxing Protection on HV and IV side
- v) Numerical Overload Alarm

Further, Numerical Back-up Over-current and earth fault protection on HV and IV side of Autotransformer shall not be combined with other protective functions in the main relays and shall be independent relays. Besides these, power transformers shall also be provided with Buchholz relay, Magnetic Oil Gauge (MOG) with low oil level alarm, protection against high oil and winding temperature and pressure relief device etc.

Suitable monitoring, control (operation of associated circuit breaker and isolator) and protection for LT auxiliary transformer connected to tertiary winding of auto-transformer for the purpose of auxiliary supply shall be provided. The over current and other necessary protection shall be provided for the auxiliary transformer. These protection and control may be provided as built in feature either in the bay controller to be provided for the auxiliary system or in the control and protection IEDs to be provided for autotransformer.

#### **c) Bus Bar Protection**

The high speed low impedance type bus bar differential protection, which is essential

to minimize the damage and maintain system stability at the time of bus bar faults, shall be provided for 765 kV, 400 kV and 220 kV buses. Duplicated bus bar protection is envisaged for 765 kV and 400 kV bus-bar protection. Bus bar protection scheme shall be such that it operates selectively for each bus and incorporate necessary features required for ensuring security.

The scheme shall have complete bus bar protection for present as well as envisaged future bays i.e. input / output modules for future bays for the bus section under present scope shall also be provided.

Bus Bar protection system for new substation shall be de-centralized (distributed) type.

In case, the bus section is provided, then each side of bus section shall have separate set of bus bar protection schemes.

Peripheral Units (PUs) shall be provided by the respective bay owners

For existing substations, the existing bus bar protection shall be augmented as per requirement.

#### **d) Local Breaker Back up Protection**

This shall be provided for each 765 kV, 400 kV and 220 kV circuit breakers and will be connected to de-energize the affected stuck breaker from both sides.

*Notes:*

1. *LBB and REF relays shall be provided separately from transformer differential relay.*
2. *LBB relay may also be provided as built-in protection function of distributed bus bar protection scheme; however, in such case separate LBB relay shall be provided for tie bays (in case of One and Half breaker scheme).*
3. *Over fluxing and overload protection can be provided as built-in feature of differential relay.*
4. *In 765 kV and 400 kV switchyard, if spare bay of half diameter is identified as future, Tie CB relay panel shall be with Auto-reclosure feature.*

#### **B.2.6 Substation Automation System**

- a) For all the new substations, state of art Substation Automation System (SAS) conforming to IEC-61850 shall be provided. The distributed architecture shall be used for Substation Automation System, where the controls shall be provided through Bay Control Units. The Bay Control Unit is to be provided bay wise for voltage level 220 kV and above. All Bay Control Units as well as protection units are normally connected through an Optical fibre high speed network. The control and monitoring of circuit breaker, dis-connector, re-setting of relays etc. can be done from Human Machine Interface (HMI) from the Control Room.

The functions of control, annunciation, disturbance recording, event logging and

measurement of electrical parameters shall be integrated in the Substation Automation System.

At the new substations, the Substation Automation System (SAS) shall be suitable for the operation and monitoring of the complete substation including proposed future bays/elements.

In the existing substations with a Substation Automation System (SAS), augmentation of existing SAS shall be done for bays under the present scope.

In the existing Substations where Substation automation is not provided, control functions shall be done through control panels.

Necessary gateway and modems (as required) shall be provided to send data to RLDC/SLDC as per their requirement and shall be provisioned with 2+2 redundancy i.e. 2 channels for Main Control Centre and 2 channels for Backup Control Centre. In order to meet this requirement, suitable redundancy at port and card level need to be ensured by the TSP to avoid any single point of failure which may lead to interruption in real-time grid operation. Accordingly, all the hardware for communication services of station as stated above shall support dual redundancy for data transmission of station to respective main and backup RLDCs. Any augmentation work at RLDC/SLDC is excluded from TSP's scope. However, all the configuration work at substation end required to send data to RLDC/SLDC shall be in the scope of TSP.

## **b) Time Synchronization Equipment**

Time Synchronization Equipment complete in all respect including antenna, cable and processing equipment required to receive time signal through GPS/NavIC or from National Physical Laboratory (NPL) through INSAT shall be provided at new substations. This equipment shall be used to synchronize SAS and IEDs etc.

### **B.3.0 Substation Support Facilities**

Certain facilities required for the operation and maintenance of substations as described below shall be provided at the new substation. In existing substation, these facilities have already been provided and will be extended/ augmented as per requirement.

#### **B.3.1 AC and DC power supplies**

For substation extensions, existing facilities shall be augmented as required.

#### **B.3.2 Fire Fighting System**

Fire-fighting system for substation including Transformer and Reactor shall conform to CEA (Measures Relating to Safety and Electric Supply) Regulations, 2023 as amended from time to time.

At existing substations, the fire-fighting systems as available shall be extended to meet the additional requirements.

### **B.3.3 Oil evacuating, Filtering, Testing and Filling apparatus**

To monitor the quality of oil for satisfactory performance of Transformers, Shunt Reactors and for periodical maintenance necessary oil evacuating, filtering, testing and filling apparatus would be provided at new substations. Oil storage tanks of adequate capacities for storage of transformer oil would be provided.

Online Transformer Oil Drying Out System shall be provided in line with the provisions of Standard Specification and Technical Parameters for Transformers and Reactors (66 kV and above Voltage Class) as amended up to date available on CEA website

### **B.3.4 Illumination**

Normal and emergency AC and DC illumination shall be provided adequately in the control room and other buildings of the substation. The switchyard shall also be provided with adequate illumination.

The lighting of the entire control room building, fire-fighting pump house, other building (if any) and switchyard shall be done by LED based low power consumption luminaries.

### **B.3.5 Control Room**

At existing substations, the adequacy of size of control room shall be ascertained and the same shall be augmented as per requirement.

### **B.3.6 GIS hall**

The Gas Insulated Switchgear (GIS) of each voltage level along with other associated equipment shall be housed inside the GIS building. The panels i.e. Bay level units, bay mimic, relay and protection panels, RTCC panels, PLCC panels, panels for telecommunication system etc. are to be placed in a separate room in the GIS building. The size of the room shall be such that all the panels for the bays under present scope shall be accommodated. The panel room shall be air-conditioned. Further, the temperature of the room shall be monitored through substation automation system by providing necessary temperature transducers. Ventilation system of suitable capacity shall be provided for each GIS hall.

One EOT Crane of suitable capacity for erection & maintenance of largest GIS component/assembly and all plant installed in the GIS switchgear room shall be provided in each GIS hall. The crane shall be capable of fulfilling all special requirements for erection & maintenance of GIS equipment. The capacity of the crane shall be sized to lift the heaviest GIS switchgear component.

For extension of existing GIS, existing facilities shall be suitably augmented/extended for GIS equipment under present scope.

### **B.3.7 Control Concept**

All the EHV circuit breakers in substation/switching stations shall be controlled and synchronized from the switchyard control room/remote control center. All the isolators shall have control from remote/local whereas the earth switches shall have local control only.

### **B.3.8 Visual Monitoring System (VMS) for watch and ward of substation premises:**

At existing substations, the Visual Monitoring System if available shall be augmented as per existing or better specification as required.

### **B.4.0 General Facilities**

- a) Line Gantry/Towers are envisaged for bays under present scope only. However, for adjacent future line bay, gantry/tower shall be designed for extension (considering Hexa conductors for 765 kV and Quad conductors for 400 kV and Twin conductor for 220 kV future lines) wherever applicable.
- b) Bay extension works at existing substation shall be executed by TSP in accordance with the requirements/provisions mentioned above. However, interface points shall be considered keeping in view the existing design/arrangement at the substation.
- c) TSP has to arrange for construction power and water on its own.
- d) All outdoor steel structures including anchor/foundation bolts shall be fully galvanized. The weight of the zinc coating shall be at least 610 g/m<sup>2</sup> however, for coastal/creek regions it shall be at least 900 g/m<sup>2</sup> (if applicable).
- e) In 765 kV & 400 kV switchyard, if spare bay of half diameter is identified as future, all the equipment for Tie & Future bay shall be designed considering the current rating of line bay i.e. 3150 A.
- f) All electrical equipment shall be installed above the Highest Flood Level (HFL) and where such equipment is not possible to be installed above Highest Flood Level, it shall be ensured that there is no seepage or leakage or logging of water.

### **B.5.0 EXTENSION OF EXISTING SUBSTATION**

The following drawings/details of existing substation are attached with the RfP documents for further engineering by the bidder.

<b>Sl. No.</b>	<b>Drawing Title</b>	<b>Drawing No./Details</b>	<b>Rev. No.</b>
<b>A.</b>	<b>Bhadla-III PS</b>		

1.0	Single Line Diagram	C/ENGG/SS/BHADLA-3/SLD	00
2.0	General Arrangement	C/ENGG/SS/NR-I/BHADLA-3/GA	00
3.0	Earthmat Layout	JAK-PGCIL-BAD-400-SYD-EMT-004	00
4.0	Visual Monitoring System	Make : Videonatics Model: NA	--
5.0	Bus Bar Protection	Make : GE Model: P741	--
6.0	Substation Automation System (SAS)	Make : GE	--
<b>B. Ramgarh PS</b>			
1.0	Single Line Diagram	C/ENGG/SS/RAMGARH PS/SLD	--
2.0	General Arrangement	C/ENGG/SS/RAMGARH-II PS/GA DRG	R0
3.0	Earthmat Layout	KEC-SA-409-RMGH-C1-ESE-306-DRG-002	R2
4.0	Visual Monitoring System	Make: Videonatics Model: Videonatics	--
5.0	Bus Bar Protection	Make: GE Model: P741	--
6.0	Substation Automation System (SAS)	Make: GE	--
<b>C. Kanpur (PG) S/s</b>			
1.0	Single Line Diagram	PG/PGCIL/KNP/Sld-drg/001	R4
2.0	General Arrangement	TCE-7320A-740-GA-3011	R7
3.0	Earthmat Layout	TCE-7320A-816-GL-3029	R2
4.0	Visual Monitoring System	Make : Videonatics Model: IVMS 3.0	--
5.0	Bus Bar Protection	Make : Hitachi Model: REB670	--
6.0	Substation Automation System (SAS)	Make : Hitachi Model: MicroSCADA SYS600 Version 10.5	--

**Location details of existing / proposed substation:****Bhadla-III PS:** 27° 40' 50.91" N, 72° 11' 52.88" E**Ramgarh PS:** 27°28'17.89" N, 70°29'38.26" E**Kanpur (PG) S/s:** 26° 23' 10.309" N, 80° 2' 54.642" E

*Note: It is to clarify that coordinates/location of S/s indicated is approximate within substation boundary. Exact coordinates for the corresponding bays/gantry for termination of the respective line shall be finalized by the bidder in coordination with site.*

**B.5.1** The existing drawings provided above and in subsequent amendments to the RfP are as received from the developer of existing substation and provided only for reference. Bidders shall follow the RfP for scope of work. Actual site conditions may be different due to other schemes being executed or subsequent revisions by the developer. Thus, Bidders are advised to visit the substation sites and acquaint themselves for details such as:

- i. Actual site conditions, Layout, Topography
- ii. Infrastructure such as roads, cable trench, drainage
- iii. Space availability in existing control room and LT panel room
- iv. Soil Investigation
- v. Fire Hydrant Layout
- vi. SAS architecture and IO list
- vii. Boundary
- viii. Design philosophy etc.

## SPECIFIC TECHNICAL REQUIREMENTS FOR COMMUNICATION

The communication requirement shall be in accordance to CEA (Technical Standards for Communication System in Power System Operations) Regulations, 2020, CEA (Technical Standards for Construction of Electrical Plants and Electric Lines) Regulations, 2022, CERC (Communication System for inter-State transmission of electricity) Regulations, 2017, CEA (Cyber Security in Power Sector) Guidelines, 2021, CEA Guidelines on Unified Philosophy for placement of PMUs in Indian Grid, March 2025 and all above documents as amended from time to time.

The communication services viz. SCADA, AGC (wherever applicable), VoIP, AMR and PMU have been identified as critical services and therefore shall be provisioned with 2+2 redundancy i.e. 2 channels for Main Control Centre and 2 channels for Backup Control Centre. In order to meet this requirement, suitable redundancy at port and card level need to be ensured by the TSP to avoid any single point of failure which may lead to interruption in real-time grid operation.

PMU to PDC communication (wherever required) shall be through 2 channels to the PDC (main) as there is no backup PDC at present.

Accordingly, all the hardware for communication services of station as stated above shall support dual redundancy for data transmission of station to respective main and backup RLDCs

The complete ISTS communication system commissioned by TSP under the RFP shall be the asset of ISTS and shall be available for usage of ISTS requirements as suggested by CTU from time to time.

TSP shall deploy Cyber Security System in compliance with CEA (Cyber Security in Power Sector) Guidelines, 2021 and CEA (Cyber Security in Power Sector) Regulation, from its date of publication/ notification and their amendments thereof.

In order to meet the requirement for grid management and operation of substations, Transmission Service Provider (TSP) shall provide the following:

### **C.1.0 FOTE Requirement for Line bays at Bhadla-III PS**

- (I) TSP shall supply, install & commission FODP with minimum 384 Fiber capacity along with panel and approach Cable (48F each) with all associated hardware fittings from gantry tower to Control Room for all the incoming lines envisaged under the present scope.
- (II) TSP shall supply, install & commission One or more STM-16 (FOTE) equipment along with panel/s supporting minimum eight (8) directions with MSP (Multiplex Section

Protection – 1+1). These directions shall exclude protected (1+1) local patching among equipment (if any). Necessary direction shall be provided in FOTE for 5 no. Of 220kV line bays, 1 no. 400kV line bay, however required optical interfaces shall be provided by upcoming entities on this line at the time of connectivity with Bhadla-III PS. The suitable DC Power Supply and backup to be provided for communication equipment.

- (III) FOTE/FODP panel shall be installed in the new Bay Kiosk (Switchyard Panel Room (SPR)). The FOTE under present scope shall be integrated by TSP with the existing FOTE at control room of Bhadla-III PS which shall be communicating with respective control center. TSP to provide necessary FODP sub rack / Splice trays/ Patch cords etc. and optical interfaces/equipment in the existing FOTE/FODP panels in control room for integration with the existing FOTE for onwards data transmission.
- (IV) In case spare optical direction is not available in the existing FOTE at the control room, the TSP shall coordinate with station owner to reconfigure the directions in existing FOTE at control room. Alternatively, The TSP may integrate the FOTE under the present scope with existing FOTE in the nearby Kiosk connected to the control room FOTE (if available with spare direction). For this purpose, TSP shall provide necessary FODP sub rack / Splice trays/ Patch cords etc. and suitable optical interfaces/ equipment in the existing FOTE/FODP panels in another Kiosk (SPR).
- (V) FOTE & FODP Eq can be accommodated in same panel to optimize space.
- (VI) The maintenance of all the communication equipment and software thereof including FOTE, FODP, PMU, approach cable, DCPS along with Battery Bank and cyber security system shall be the responsibility of TSP.

### **C.2.0 FOTE Requirement for line bays at Ramgarh PS**

- (I) TSP shall supply, install & commission FODP with minimum 240 Fiber capacity along with panel and approach Cable (48F each) with all associated hardware fittings from gantry tower to Control Room for all the incoming lines envisaged under the present scope.
- (II) TSP shall supply, install & commission One or more STM-16 (FOTE) equipment along with panel/s supporting minimum Three (5) directions with MSP (Multiplex Section Protection – 1+1). These directions shall exclude protected (1+1) local patching among equipment (if any). Necessary directions shall be provided in FOTE for 2 no. of 220 kV line bay, 1 no. of 400kV line bay, however required optical interfaces shall be provided by upcoming entities on this line at the time of connectivity with Ramgarh PS. A suitable DC Power Supply and backup to be provided for communication equipment.

- (III) FOTE/FODP panel shall be installed in the new Bay Kiosk (Switchyard Panel Room (SPR)). The FOTE under present scope shall be integrated by TSP with the existing FOTE at control room of Ramgarh PS which shall be communicating with respective control center. TSP to provide necessary FODP sub rack / Splice trays/ Patch cords etc. and optical interfaces/equipment in the existing FOTE/FODP panels in control room for integration with the existing FOTE for onwards data transmission.

In case spare optical direction is not available in the existing FOTE at the control room, the TSP shall coordinate with station owner to reconfigure the directions in existing FOTE at control room. Alternatively, The TSP may integrate the FOTE under the present scope with existing FOTE in the nearby Kiosk connected to the control room FOTE (if available with spare direction). For this purpose, TSP shall provide necessary FODP sub rack / Splice trays/ Patch cords etc. and suitable optical interfaces/ equipment in the existing FOTE/FODP panels in another Kiosk (SPR).

- (IV) FOTE & FODP Eq can be accommodated in same panel to optimize space.
- (V) The maintenance of all the communication equipment and software thereof including FOTE, FODP, PMU, approach cable, DCPS along with Battery Bank and cyber security system shall be the responsibility of TSP.

### **C.3.0 Specific Requirement for Phasor Measurement Units (PMUs)**

TSP shall supply, install and commission required No. of Phasor Measurement Units (PMUs) as per the “Guidelines on Unified Philosophy for placement of PMUs in Indian Grid” issued vide CEA letter No. CEA-PS-14-12/9/2024-PSETD Division dated 19.03.2025 for the scope of this RFP. The PMUs shall be provided with LAN switch and shall connect with LAN switch of control room of respective substations/ generating stations with Fibre Optic cable. The PMUs shall be connected with the FOTE at Substation/ generating stations for onwards data transmission to the PDC (Phasor Data Concentrator) located at respective RLDC. Configuration work in existing PDC at RLDC for new PMU integration shall be done by respective RLDC, however all the necessary support in this regard shall be ensured by TSP. The maintenance of all the PMUs and associated equipment shall be the responsibility of TSP.

Note: Existing Station owner/s to provide necessary support to integrate different equipment and applications of new extended bays with the existing substation e.g. Communication (through FOTE), Voice etc. for smooth operation and monitoring of new added grid elements.

### **C.4.0 Specific Requirement for UNMS Integration of FOTE**

#### **Communication system integration in UNMS/CSMS**

TSP is to ensure integration of communication system into UNMS/CSMS as per following:

“The new communication equipment/ system under the present scope shall be compatible for integration with existing regional level NMS system/ Centralized Supervision & Monitoring System (CSMS) i.e. Regional UNMS. The local configuration of the new communication equipment/ system at the station end shall be the responsibility of TSP as per followings. The configuration work in the existing centralized NMS/ UNMS at Control center end, for integration of new Communication equipment/ system shall be done by Regional ULDC Team/ NMT, however all the necessary support in this regard shall be ensured by TSP.

**Requirement for integration of Communication Equipment/ system with Regional UNMS:**

1. TSP shall ensure that NMS/EMS/NE supplied by them is NBI compliant and all FCAPS functionality is supported in the NBI such as NE Inventory, Hardware Inventory– Shelf/Slot/Card/SFP/Port, Topology, Protections, Alarms, Performance-real time and periodic, Performance KPI parameters (E-1, STM, Ethernet), Remote Configuration, Cross Connects, Trails and Circuits, Services Provisioning (NE), E-1, STM, Ethernet, TX and RX Trace, loop back and details are published in the NBI guide for the configuration parameters.
2. TSP shall be obliged to provide/share all necessary documentations such as NBI Guide/MIB/IDL/WSDL/API files etc. for onward integration of their NMS/EMS/NE with regional UNMS.
3. The following support shall be provided by TSP for integration of their supplied equipment with regional UNMS:
  - Enabling and activating NBI license in their EMS/NMS and providing NBI login access along with User credentials
  - Assist in verifying NBI Connectivity with UNMS vendor for the successful communication and retrieval of data.
  - Assist in troubleshooting (if required) for NBI connectivity along with UNMS vendor for the communication and retrieval of data.
4. For standalone NE which is not integrated with any EMS/NMS, TSP shall provide modality of complete FCAPS data acquisition as above through industry standard programmatic methods and provide the CLI command manual.”

**Figure F.1**

---

**Frequently Asked Queries:**

**Substation**

- 1.1 We understand that space for storage of O&M spare shall be provided by the existing owner within the station boundary without any cost. Kindly confirm.

**Reply:** Space for storage of O&M spares shall be arranged by TSP on its own.

- 1.2 We presume that the O&M for the end Termination bays will be in the scope of the TSP and TSP shall not be liable for any payment towards O&M to the existing owner of the substation. Kindly confirm.

**Reply:** Operation and maintenance of the bays is solely the responsibility of the TSP. Further, TSP shall follow CEA's "Operation and Maintenance (O&M) guidelines and Standard Format for Memorandum of Understanding between New TSP and Existing TSP" issued by CEA vide its letter No. I/28514/2023 dated 22.06.2023.

- 1.3 With reference to subject scheme of existing sub-station, we assumed following scope of work:

- (a) We assumed internal road is available and need not to be consider in the present scope of work.
- (b) Drainage is available and need not to consider in the present scope of work.
- (c) Cable trench extension adjacent to Main cable trench only under present scope of work.
- (d) Levelled area being provided by developer for bay extension.

**Reply:** Regarding requirement of internal road, drainage, cable trench, leveling of the bay extension area, bidder is advised to visit site and acquaint themselves with the provisions/facilities available at substation.

- 1.4 Kindly provide the soil investigation report of soil parameters of existing substation.

**Reply:** Bidder is advised to visit the substation site and ascertain the requisite parameters.

- 1.5 Kindly confirm, energy accounting of aux. power consumption. Whether it will be on chargeable basis or part of transmission loss.

**Reply:** It will be on a chargeable basis.

- 1.6 We understand that VMS requirement is for unmanned stations only. For Manned stations VMS is not compulsory.

**Reply:** VMS shall be provided in line with requirements of RfP document.

- 1.7 It is understood that Construction water and power shall be provided free of cost to TSP by the respective substation owner for construction of new bays.

**Reply:** Arrangement of construction power and water is in the scope of TSP.

- 1.8 It is understood that the existing fire hydrant system shall be extended by the TSP for bay extension.

**Reply:** Existing fire hydrant system shall be extended from existing system (if required)

- 1.9 Please clarify the Status of land acquisition for new Substations. Whether the lands have been acquired by BPC and will be transferred to TSP.

**Reply:** The acquisition of land for new substation is in the scope of TSP.

- 1.10 We understood that no any dedicated metering CT and CVT required for Line/feeders. Further, we understood that requisite Energy meters for various 765 kV, 400 kV and 220 kV Feeders shall be provided and installed by CTU free of cost to TSP.

**Reply:** Dedicated metering CT and CVT are not required for line/feeders. Metering core of existing CT/CVT can be used provided accuracy class matches with metering requirement. Requisite Special Energy Meters shall be provided and installed by CTU at the cost of TSP in C&P panel subject to space availability, else, in separate metering panel (to be provided by TSP at its cost).

- 1.11 A draft copy of the Connection Agreement may be furnished. A draft copy of the Connection Agreement may be furnished.

**Reply:** Web page link [https://www.ctuil.in/formats\\_gna\\_transition](https://www.ctuil.in/formats_gna_transition)

- 1.12 Please clarify whether the spare 765 kV single phase Reactor unit for Bus reactor shall be provided with 1ph 765 kV CB.

**Reply:** As per RfP, the spare 1-Ph reactor unit shall be utilized for all the bus and switchable line reactor banks (including for future reactor banks). Hence, 1ph 765 kV CB shall also be provided with spare 1-Ph reactor for utilizing with bus reactor as well as switchable line reactor.

- 1.13 It is understood that existing busbar protection has provision for future bays and also PUs are available for future bays. BPC to confirm availability of CU and PU for bays under present scope of work at existing substations. BPC may kindly confirm availability of communication ports for integrating new PUs with the existing CUs at existing substations.

**Reply:** Bus Bar Protection with Central Unit (CU) is required for the new bus section as specified in RfP. Peripheral Units (PUs) shall be provided by the respective bay owner. Further, augmentation/replacement of existing CU, if required, to meet the system requirement shall also be provided for proper functioning of bus bar protection.

- 1.14 For SCADA, it is understood that necessary process I/O shall be available for future bays and accordingly license for same. BPC to confirm.

**Reply:** Necessary process I/O along with license shall be in the scope of the successful bidder.

- 1.15 No separate FF system is envisaged under the present scope of work for existing substation. BPC to confirm.

**Reply:** Existing fire-fighting systems shall be extended to meet the additional requirements under present scope.

- 1.16 PLCC for 220 kV Lines are not under the scope of TSP. BPC to Confirm. It is requested to provide Type of Coupling for 220 kV Transmission Lines under present scope.

**Reply:** PLCC for 220 kV line is in the scope of developer of the line.

Inter circuit coupling for 220 kV D/C and phase to phase coupling for 220 kV S/C shall be applicable for PLCC.

- 1.17 BPC is requested to confirm the availability of space in the existing control rooms at existing substation for execution of extension work under current project.

**Reply:** Switchyard Panel Rooms are generally required for AIS type substation and relay room are required for GIS type substation. Further, if needed, the control room shall be augmented as per requirement.

## Communication

- 2.1 What are the usage of OPGW, FOTE, PMU etc. under communication requirement Of RFP?

**Reply:** User shall be responsible for providing compatible equipment along with appropriate interface for uninterrupted communication with the concerned control center and shall be responsible for successful integration with the communication system provided by CTU.

Communication systems e.g. OPGW, FOTE etc. and PMU are required for grid operation through RLDC/SLDC, speech communication, tele-protection and tele-metering.

- 2.2 Is space for installation of communication panels are provided to TSP in existing Substations incase new bays are in the scope of TSP?

**Reply:** The space related issues are deliberated in the RfP itself. TSP to install FOTE/FODP panels in the new Bay Kiosk (Switchyard Panel Room (SPR)) / Bay Kisok/ Relay Panel Room (in case of GIS S/s). Further, TSP to connect and integrate

the proposed FOTE with the existing FOTE in the control room to complete the communication path upto RLDC.

In Case 132 kV Substation TSP shall accommodate the said panels either by extension of existing control room or other arrangements.

2.3 How is the OPGW laying done in case of LILO lines?

**Reply:**

In case LILO lines are on same towers (e.g. both Line in and Line Out portion are on same towers, generally done LILO of S/C lines). Then one No. OPGW having fibers equal to no of fibers in main line OPGW shall be required to be install by TSP on both earthwire peak on 400 kV and 765 kV lines where two E/W peaks are available. On 220 kV and 132 kV lines where only one E/W peak is available TSP to install one No. OPGW having fibers double the No. of fibers in main line OPGW.

In case LILO lines are on different towers (e.g. both Line In and Line Out portion are on different towers, generally done LILO of D/C lines). Then one No. OPGW having fibers equal to no of fibers in main line OPGW shall be required to be install by TSP on one earthwire peak and conventional earthwire on second earthwire peak, on both Line In and Line Out portion towers of 400 kV and 765 kV lines. On 220 kV and 132 kV lines where only one E/W peak is available TSP to install one No. OPGW having fibers equal to no of fibers in main line OPGW in place of conventional earthwire.

2.4 How is the OPGW laying done in the case of Multi circuit Towers?

**Reply:**

In case two different lines are using common multi circuit portion for some distance (originating from different stations, may be terminating on same or on different stations), Then OPGW having fibers equal to fibers laid on different lines to be installed on both E/W peaks for common M/C portion of 765 kV & 400 kV lines by the TSP. In case 220/132 kV lines using multi circuit portion where single E/W peak is available, required OPGW to accommodate all the OPGW fibers of different transmission lines may be installed for common multi circuit portion.

2.5 How PMUs are integrated for new bays at existing Substations?

**Reply:** PMU data of new bays to be provided in the ethernet port of switch at control room and thereafter to be connected with existing FOTE of existing substation to send data to PDC of RLDC by TSP. These PMUs shall be provided with GPS clock and LAN switch and shall connect with LAN switch of control room of respective substations with Fiber Optic cable. In this regard, the “Guidelines on Unified Philosophy for placement of PMUs in Indian Grid” issued vide letter No. CEA-PS-14-12/9/2024-PSETD Division dated 19.03.2025 shall be followed.

2.6 Is Spare direction available in existing FOTE for integration with new bay kiosk FOTE

**Reply:** The FOTE under present scope shall be integrated by TSP with the existing FOTE at control room of substation for onwards data transmission. In case spare optical direction is not available in the existing FOTE at the control room, the TSP shall coordinate with station owner to reconfigure the directions in existing FOTE at control room.

2.7 What is the distance from LILO point to proposed substation for feasibility of repeater station?

**Reply:** Tentative Location of LILO point shall be as per survey report of BPC however exact location to be ascertained after detailed survey by TSP.

2.8 What is the make and model of existing OPGW in case LILO of main line at new substation?

**Reply:** All OPGW (alongwith optical fibers) meet Central Electricity Authority (Technical Standards for Communication System in Power System Operations) Regulations, 2020 and bidder shall install OPGW accordingly.

2.9 In case of LILO of existing line at new substation who shall provide PMUs at existing substation bays?

**Reply:** TSP shall provide the PMUs for the scope under RfP in compliance of “Guidelines on Unified Philosophy for placement of PMUs in Indian Grid” issued vide letter No. CEA-PS-14-12/9/2024-PSETD Division dated 19.03.2025.

**Planning:**

3.1 Whether the Project/ Elements are eligible for early commissioning incentive as per MoP, GoI order dated 15.07.2015.?

**Reply:** Commissioning is to be done as per the timeline mentioned in RfP. However, early commissioning shall be treated as per applicable CERC Regulations/orders.

**TRANSMISSION SERVICE AGREEMENT**

**FOR**

**DEVELOPMENT AND OPERATION OF INTER-  
STATE TRANSMISSION SYSTEM**

**FOR TRANSMISSION OF ELECTRICITY  
THROUGH TARIFF BASED COMPETITIVE  
BIDDING FOR**

**AUGMENTATION AT BHADLA-III, RAMGARH PS  
AND KANPUR (PG)**

**BETWEEN THE**

**CENTRAL TRANSMISSION UTILITY OF INDIA  
LIMITED  
(NODAL AGENCY)**

**AND  
[INSERT NAME OF THE SPV]**

**.....2026**

**CONTENTS**

1	Definitions and Interpretations .....	5
2	Effectiveness and Term of Agreement.....	18
3	Conditions Subsequent.....	20
4	Development of the Project.....	24
5	Construction of the Project.....	29
6	Connection and commissioning of the Project.....	34
7	Operation and Maintenance of the Project.....	39
8	Availability of the project.....	40
9	Insurances .....	41
10	Billing And Payment of Transmission Charges .....	43
11	Force Majeure.....	44
12	Change in Law.....	49
13	Events of Default and Termination.....	52
14	Liability and Indemnification .....	57
15	Assignments and Charges .....	63
16	Governing Law and Dispute Resolution .....	65
17	Representation and Warranties.....	67
18	Independent Engineer .....	69
19	Miscellaneous Provisions .....	71

## Transmission Service Agreement

**THIS TRANSMISISON SERVICE AGREEMENT** (hereinafter referred to as “TSA” or “Agreement” or “the Agreement” or “this Agreement”) is made on the ..... [Insert day] of..... [Insert month] of Two Thousand and.....[Insert Year]

### **BETWEEN:**

The.....[Insert name and registered address of Nodal Agency for the project], acting as a Nodal Agency (referred to as the “Nodal Agency”), which expression shall unless repugnant to the context or meaning thereof include its successors, and permitted assigns) as Party of the one part;

### **AND**

..... [Insert Name of the Transmission Service Provider], incorporated under the Companies Act, 1956/ Companies Act, 2013 (as the case may be), having its registered office at.....(herein after referred to as “Transmission Service Provider” or “TSP” or “ISTS Licensee”, which expression shall unless repugnant to the context or meaning thereof include its successors, and permitted assigns) as Party of the other part;

**(“Nodal Agency” and “TSP” are individually referred to as “Party” and collectively as the “Parties”)**

### **AND WHEREAS:**

- A) In accordance with the Bidding Guidelines, the Bid Process Coordinator (hereinafter referred to as BPC) had initiated a competitive e-reverse bidding process through issue of RFP for selecting a Successful Bidder to build, own, operate and transfer the Project comprising of the Elements mentioned in Schedule 1 (hereinafter referred to as the Project)
- B) Pursuant to the said e-reverse bidding process, the BPC has identified the Successful Bidder, who will be responsible to set up the Project on build, own, operate and transfer basis to provide Transmission Service in accordance with the terms of this Agreement and the Transmission License.

- C) The Selected Bidder have submitted the Contract Performance Guarantee and acquired one hundred percent (100%) of the equity shareholding of .....(Insert name of the SPV), along with all its related assets and liabilities in terms of the provisions of the Share Purchase Agreement.
- D) The TSP has agreed to make an application for a Transmission License to the Commission for setting up the Project on build, own, operate and transfer basis.
- E) The TSP has further agreed to make an application to the Commission for the adoption of the Transmission Charges under Section 63 of the Electricity Act, 2003, along with a certification from the Bid Evaluation Committee in accordance with the Bidding Guidelines issued by Ministry of Power, Government of India.
- F) The TSP has agreed to execute the agreement(s) required, if any, under Sharing Regulations within fifteen (15) days from the date of grant of Transmission License from the Commission.
- G) The TSP agrees to the terms and conditions laid down under Sharing Regulations, for making available the ISTS and charge the Transmission Charges in accordance with the terms and conditions of Sharing Regulations.
- H) The billing, collection and disbursement of the Transmission Charges by the CTU to the ISTS Licensee shall be governed as per Sharing Regulations.
- I) The terms and conditions stipulated in the Transmission License issued by the Commission to the TSP shall be applicable to this Agreement and the TSP agrees to comply with these terms and conditions. In case of inconsistency between the Transmission License terms & conditions and the conditions of this Agreement, the conditions stipulated in the Transmission License granted by the Commission shall prevail.

**NOW, THEREFORE, IN CONSIDERATION OF THE PREMISES AND MUTUAL AGREEMENTS, COVENANTS AND CONDITIONS SET FORTH HEREIN, IT IS HEREBY AGREED BY AND BETWEEN THE PARTIES HERETO AS FOLLOWS:**

**ARTICLE: 1**

**1 DEFINITIONS AND INTERPRETATIONS**

**1.1 Definitions:**

1.1.1 The words / expressions used in this Agreement, unless as defined below or repugnant to the context, shall have the same meaning as assigned to them by the Electricity Act, 2003 and the rules or regulations framed there under including those issued / framed by the Commission (as defined hereunder), as amended or re-enacted from time to time or the General Clauses Act, failing which it shall bear its ordinary English meaning.

The words/expressions when used in this Agreement shall have the respective meanings as specified below:

**“Acquisition Price”** shall have the same meaning as defined in the Share Purchase Agreement;

**“Act”** or **"Electricity Act"** or **“Electricity Act 2003”** shall mean the Electricity Act, 2003 and any amendments made to the same or any succeeding enactment thereof;

**“Affiliate”** shall mean a company that either directly or indirectly

- i. controls or
- ii. is controlled by or
- iii. is under common control with

a Bidding Company (in the case of a single company) or a Member (in the case of a Consortium) and **“control”** means ownership by one entity of at least twenty six percent (26%) of the voting rights of the other entity;

**“Availability”** in relation to the Project or in relation to any Element of the Project, for a given period shall mean the time in hours during that period the Project is capable to transmit electricity at its Rated Voltage and shall be expressed in percentage of total hours in the given period and shall be calculated as per the procedure contained in Appendix –IV to Central Electricity Regulatory Commission (Terms and Conditions of Tariff) Regulations, 2024, attached herewith in Schedule 6;

**“Bid”** shall mean technical bid and financial bid submitted by the Bidder, in response to the RFP, in accordance with the terms and conditions of the RFP;

**“Bid Deadline”** shall mean the last date and time for submission of the Bid in response to RFP, as specified in the RFP;

**“Bidding Company”** shall refer to such single company that has made a Response to RFP for the Project;

**“Bidding Consortium / Consortium”** shall refer to a group of companies that has collectively made a Response to RFP for the Project;

**“Bid Documents”** or **“Bidding Documents”** shall mean the RFP, along with all attachments thereto or clarifications thereof;

**“Bidding Guidelines”** shall mean the “Tariff Based Competitive Bidding Guidelines for Transmission Service” and “Guidelines for Encouraging Competition in Development of Transmission Projects” issued by Government of India, Ministry of Power under Section – 63 of the Electricity Act as amended from time to time;

**“Bid Process Coordinator”** or **“BPC”** shall mean a person or its authorized representative as notified by the Government of India, responsible for carrying out the process for selection of Bidder who will acquire Transmission Service Provider;

**“Bill”** shall mean any bill raised by the CTU on the DICs to recover the Transmission Charges pursuant to the Sharing Regulations;

**“Business Day”** shall mean a day other than Sunday or a statutory holiday, on which the banks remain open for business in the State in which the Nodal Agency’s registered office is located and the concerned TSP are located;

**“CEA”** shall mean the Central Electricity Authority constituted under Section -70 of the Electricity Act;

**“Change in law”** shall have the meaning ascribed thereto in Article 12;

**“Commercial Operation Date”** or **“COD”** shall mean the date as per Article 6.2;

**“Commission”** or **“CERC”** shall mean the Central Electricity Regulatory Commission referred to in sub-section (1) of Section 76 of the Electricity Act, 2003 or its successors and assigns;

**“Competent Court of Law”** shall mean the Supreme Court or any High Court, or any tribunal or any similar judicial or quasi-judicial body in India that has jurisdiction to adjudicate upon issues relating to the Project;

**“Connection Agreement”** shall mean the agreement between the CTU or STU or any other concerned parties and the TSP, setting out the terms relating to the connection of the Project to the Inter-connection Facilities and use of the Inter State Transmission System as per the provisions of the IEGC, as the case may be;

**“Consultation Period”** shall mean the period of sixty (60) days or such longer period as the Parties may agree, commencing from the date of issue of a TSP’s Preliminary Notice or a Nodal Agency’s Preliminary Termination Notice, as provided in Article 13 of this Agreement, for consultation between the Parties to mitigate the consequence of the relevant event having regard to all the circumstances;

**“Consents, Clearances and Permits”** shall mean all authorizations, licenses, approvals, registrations, permits, waivers, privileges, acknowledgements, agreements, or concessions required to be obtained from or provided by any concerned authority for the development, execution and operation of Project including without any limitation for the construction, ownership, operation and maintenance of the Transmission Lines and/or sub-stations;

**“Construction Period”** shall mean the period from (and including) the Effective Date of the Transmission Service Agreement up to (but not including) the COD of the Element of the Project in relation to an Element and up to (but not including) the COD of the Project in relation to the Project;

**“Contractors”** shall mean the engineering, procurement, construction, operation & maintenance contractors, surveyors, advisors, consultants, designers, suppliers to the TSP and each of their respective sub-contractors (and each of their respective successors and permitted assigns) in their respective capacities as such;

**“Contract Performance Guarantee”** shall mean the irrevocable unconditional bank guarantee, or insurance surety bond or Payment on Order Instrument submitted and to be submitted by the TSP or by the Selected Bidder on behalf of the TSP to the Nodal Agency from a bank mentioned in Annexure 17 of the RFP, in the form attached here to as Schedule 8 (for bank guarantee) or Schedule-8A (for insurance surety bond issued by any of the insurance companies authorized by Insurance Regulatory and Development Authority of India), or Schedule-8B (for Payment on Order Instrument issued by PFC/REC/IREDA) in accordance with Article 3 of this Agreement and which shall include the additional bank guarantee or insurance surety bond or Payment on Order Instrument furnished by the TSP under this Agreement;

**“Contract Year”**, for the purpose of payment of Transmission Charges, shall mean the period beginning on the COD, and ending on the immediately succeeding March 31 and thereafter each period of 12 months beginning on April 1 and ending on March 31 provided that the last Contract Year shall end on the last day of the term of the TSA;

**“CTU”** or **“Central Transmission Utility”** shall have same meaning as defined in the Electricity Act, 2003;

**“Day”** shall mean a day starting at 0000 hours and ending at 2400 hours;

**“D/C”** shall mean Double Circuit;

**“Designated ISTS Customers”** or **“DICs”** shall have the meaning as ascribed in the Sharing Regulations;

**“Dispute”** shall mean any dispute or difference of any kind between the Parties, in connection with or arising out of this Agreement including any issue on the interpretation and scope of the terms of this Agreement as provided in Article 16;

**“Effective Date”** for the purposes of this Agreement, shall have the same meaning as per Article 2.1 of this Agreement;

**“Electrical Inspector”** shall mean a person appointed as such by the Government under sub-section (1) of Section 162 of the Electricity Act 2003 and also includes Chief Electrical Inspector;

**“Electricity Rules 2005”** shall mean the rules framed pursuant to the Electricity Act 2003 and as amended from time to time;

**“Element”** shall mean each Transmission Line or each circuit of the Transmission Lines (where there are more than one circuit) or each bay of Sub-station or switching station or HVDC terminal or inverter station of the Project, including ICTs, Reactors, SVC, FSC, etc. forming part of the ISTS, which will be owned, operated and maintained by the concerned ISTS Licensee, and which has a separate Scheduled COD as per Schedule 2 of this Agreement and has a separate percentage for recovery of Transmission Charges on achieving COD as per Schedule 5 of this Agreement;

**“Event of Default”** shall mean the events as defined in Article 13 of this Agreement;

**“Expiry Date”** shall be the date which is thirty five (35) years from the COD of the Project;

**“Financial Closure”** shall mean the first Business Day on which funds are made available to the TSP pursuant to the Financing Agreements;

**“Financially Evaluated Entity”** shall mean the company which has been evaluated for the satisfaction of the financial requirement set forth in the RFP;

**“Financing Agreements”** shall mean the agreements pursuant to which the TSP is to finance the Project including the loan agreements, security documents, notes, indentures, security agreements, letters of credit and other documents, as may be amended, modified, or replaced from time to time, but without in anyway increasing the liabilities of the Designated ISTS Customers / Nodal Agency;

**“Financial Year”** shall mean a period of twelve months at midnight Indian Standard Time (IST) between 1st April & 31st March;

**“Force Majeure”** and **“Force Majeure Event”** shall have the meaning assigned thereto in Article 11;

**“GOI”** shall mean Government of India;

**“Grid Code” / “IEGC”** shall mean the Grid Code specified by the Central Commission under Clause (h) of sub-section (1) of Section 79 of the Electricity Act;

**“Independent Engineer”** shall mean an agency/ company, appointed by Nodal Agency in accordance with the Guidelines for Encouraging Competition in Development of Transmission Projects.

**“Indian Governmental Instrumentality”** shall mean Government of India, Government of any State in India or any ministry, department, board, authority, agency, corporation, commission under the direct or indirect control of Government of India or any State Government or both, any political sub-division of any of them including any court or Commission or tribunal or judicial or quasi-judicial body in India but excluding the CTU, TSP and the Designated ISTS Customers;

**“Insurances”** shall mean the insurance cover to be obtained and maintained by the TSP in accordance with Article 9 of this Agreement;

**“Interconnection Facilities”** shall mean the facilities as may be set up for transmission of electricity through the use of the Project, on either one or both side of generating station’s / CTU’s / STU’s / ISTS Licensee’s / Designated ISTS Customer’s substations (as the case may be) which

shall include, without limitation, all other transmission lines, gantries, substations and associated equipment not forming part of the Project;

**“ISTS Licensee”** shall be the TSP under this Agreement, consequent to having been awarded a Transmission License by the CERC and shall be referred to as the TSP or the ISTS Licensee, as the context may require in this Agreement;

**“Law” or “Laws”** in relation to this Agreement, shall mean all laws including electricity laws in force in India and any statute, ordinance, rule, regulation, notification, order or code, or any interpretation of any of them by an Indian Governmental Instrumentality having force of law and shall include all rules, regulations, decisions and orders of the Commission;

**“Lead Member of the Bidding Consortium” or “Lead Member”** shall mean a company who commits at least 26% equity stake in the Project, meets the technical requirement as specified in the RFP and so designated by other Member(s) in Bidding Consortium;

**“Lenders”** means the banks, financial institutions, multilateral funding agencies, non banking financial companies registered with the Reserve Bank of India (RBI), insurance companies registered with the Insurance Regulatory & Development Authority (IRDA), pension funds regulated by the Pension Fund Regulatory & Development Authority (PFRDA), mutual funds registered with Securities & Exchange Board of India (SEBI), etc., including their successors and assigns, who have agreed on or before COD of the Project to provide the TSP with the debt financing described in the capital structure schedule, and any successor banks or financial institutions to whom their interests under the Financing Agreements may be transferred or assigned;

Provided that, such assignment or transfer shall not relieve the TSP of its obligations to the Nodal Agency under this Agreement in any manner and shall also does not lead to an increase in the liability of the Nodal Agency;

**“Lenders Representative”** shall mean the person notified by the Lender(s) in writing as being the representative of the Lender(s) or the Security Trustee and such person may from time to time be replaced by the Lender(s) pursuant to the Financing Agreements by written notice to the TSP;

**“Letter of Intent” or “LOI”** shall have the same meaning as in the RFP;

**“Member in a Bidding Consortium / Member”** shall mean each company in the Bidding Consortium;

**“Month”** shall mean a period of thirty (30) days from (and excluding) the date of the event;

**“Monthly Transmission Charges”** for any Element of the Project, after COD of the Element till COD of the Project, and for the Project after COD of the Project, shall mean the amount of Transmission Charges as specified in Schedule 5 of this Agreement multiplied by no. of days in the relevant month and divided by no. of days in the year;

**“National Load Despatch Centre”** shall mean the centre established as per sub-section (1) of Section 26 of the Electricity Act 2003;

**“Nodal Agency”** shall mean CTU, which shall execute and implement the Transmission Service Agreement (TSA);

Provided that while taking major decisions, CTU shall consult CEA on technical matters and any other matter it feels necessary.

**“Notification”** shall mean any notification, issued in the Gazette of India;

**“Operating Period”** for any Element of the Project shall mean the period from (and including) the COD of such Element of the Project, up to (and including) the Expiry Date and for the Project, shall mean the period from (and including) the COD of the Project, up to (and including) the Expiry Date;

**“Parent Company”** shall mean an entity that holds at least twenty six percent (26%) of the paid - up equity capital directly or indirectly in the Bidding Company or in the Member in a Bidding Consortium, as the case may be;

**“Payment on Order Instrument”** shall mean Letter of Undertaking from Indian Renewable Energy Development Agency Limited (IREDA) or Power Finance Corporation Limited (PFC) or REC Limited (REC) [the three non-banking financial institutions under Ministry of New & Renewable Energy (MNRE)/ Ministry of Power (MoP)], to pay in case situation of default of Transmission Service Provider (TSP) in terms of tender conditions/Power Purchase Agreement (PPA) arises. Such Letter(s) will have same effect as that of a Bank Guarantee issued by any public sector bank. Such "Payment on Order instrument" would have terms and conditions similar to that of any Bank Guarantee given by any public sector bank and would promise to pay the Nodal Agency on demand within stipulated time. TSPs can seek such Letters(s) by offering due security to the above mentioned three non-banking financial institutions mentioned above (IREDA, PFC & REC). Nodal Agency shall not accept the instrument of 'Letter of Undertaking' as described above or

in any other form, from any other non-banking financial institutions or bank, except IREDA, PFC & REC.

**“Preliminary Termination Notice”** shall mean a Nodal Agency’s Preliminary Termination Notice as defined in Article 13 of this Agreement;

**“Project”** shall mean Augmentation at Bhadla-III, Ramgarh PS and Kanpur (PG), as detailed in Schedule 1 of this Agreement;

**“Project Assets”** shall mean all physical and other assets relating to and forming part of the Project including:

- (a) rights over the Site for substations, ROW for transmission lines;
- (b) tangible & intangible assets such as civil works and equipment including foundations, embankments, pavements, electrical systems, communication systems, relief centres, administrative offices, Sub- stations, software, tower and sub-stations designs etc;
- (c) project facilities situated on the Site;
- (d) all rights of the TSP under the project agreements;
- (e) financial assets, such as receivables, security deposits etc;
- (f) insurance proceeds; and
- (g) Applicable Permits and authorisations relating to or in respect of the Transmission System;”

**“Project Execution Plan”** shall mean the plan referred to in Article 3.1.3 (c) hereof;

**“Prudent Utility Practices”** shall mean the practices, methods and standards that are generally accepted internationally from time to time by electric transmission utilities for the purpose of ensuring the safe, efficient and economic design, construction, commissioning, operation, repair and maintenance of the Project and which practices, methods and standards shall be adjusted as necessary, to take account of:

- (i) operation, repair and maintenance guidelines given by the manufacturers to be incorporated in the Project,
- (ii) the requirements of Law, and
- (iii) the physical conditions at the Site;

(iv) the safety of operating personnel and human beings;

**“Rated Voltage”** shall mean voltage at which the Transmission System is designed to operate or such lower voltage at which the line is charged, for the time being, in consultation with the Central Transmission Utility;

**“Rebate”** shall have the meaning as ascribed to in Article 10.3 of this Agreement;

**“RFP”** shall mean Request for Proposal dated 25.03.2026 along with all schedules, annexures and RFP Project Documents attached thereto, issued by the BPC for tariff based competitive bidding process for selection of Bidder as TSP to execute the Project, including any modifications, amendments or alterations thereto;

**“RFP Project Documents”** shall mean the following documents to be entered into in respect of the Project, by the Parties to the respective agreements:

- a. Transmission Service Agreement,
- b. Share Purchase Agreement,
- c. Agreement(s) required under Sharing Regulations and
- d. Any other agreement as may be required;

**“RLDC”** shall mean the relevant Regional Load Dispatch Centre as defined in the Electricity Act, 2003, in the region(s) in which the Project is located;

**“RPC”** shall mean the relevant Regional Power Committee established by the Government of India for the specific Region(s) in accordance with the Electricity Act, 2003 for facilitating integrated operation of the Power System in that Region;

**“Scheduled COD”** in relation to an Element(s) shall mean the date(s) as mentioned in Schedule 2 as against such Element(s) and in relation to the Project, shall mean the date as mentioned in Schedule 2 as against such Project, subject to the provisions of Article 4.4 of this Agreement, or such date as may be mutually agreed among the Parties;

**“Scheduled Outage”** shall mean the final outage plan as approved by the RPC as per the provisions of the Grid Code;

**“Selected Bid”** shall mean the technical Bid and the Final Offer of the Selected Bidder submitted during e-reverse bidding, which shall be downloaded and attached in Schedule 7 on or prior to the Effective Date;

**“Share Purchase Agreement”** shall mean the agreement amongst REC Power Development and Consultancy Limited, .....(Insert name of the SPV), and the Successful Bidder for the purchase of one hundred (100%) per cent of the shareholding of the .....(Insert name of the SPV), for the Acquisition Price, by the Successful Bidder on the terms and conditions as contained therein;

**“Sharing Regulations”** shall mean the Central Electricity Regulatory Commission (Sharing of Inter-State Transmission Charges and Losses) Regulations, 2020 and as amended from time to time;

**“Site”** in relation to a substation, switching station or HVDC terminal or inverter station, shall mean the land and other places upon which such station / terminal is to be established;

**“SLDC”** shall mean the State Load Despatch Centre established as per sub-section (1) of Section 31 of the Electricity Act 2003;

**“STU”** or **“State Transmission Utility”** shall be the Board or the Government company, specified as such by the State Government under sub-section (1) of Section 39 of the Electricity Act 2003;

**“Successful Bidder”** or **“Selected Bidder”** shall mean the Bidder selected pursuant to the RFP and who has to acquire one hundred percent (100%) equity shares of .....(Insert name of the SPV), along with all its related assets and liabilities, which will be responsible as the TSP to establish the Project on build, own, operate and transfer basis as per the terms of the TSA and other RFP Project Documents;

**“TSP’s Preliminary Notice”** shall mean a notice issued by the TSP in pursuant to the provisions of Article 13.3 of this Agreement;

**“Target Availability”** shall have the meaning as ascribed hereto in Article 8.2 of this Agreement;

**“Technically Evaluated Entity”** shall mean the company which has been evaluated for the satisfaction of the technical requirement set forth in RFP;

**“Termination Notice”** shall mean a Nodal Agency’s Termination Notice given by the Nodal Agency to the TSP pursuant to the provisions of Articles 3.3.2, 3.3.4, 4.4.2, 5.8, 13.2 and 13.3 of this Agreement for the termination of this Agreement;

**“Term of Agreement”** for the purposes of this Agreement shall have the meaning ascribed thereto in Article 2.2 of this Agreement;

**“Transmission Charges”** shall mean the Final Offer of the Selected Bidder during the e-reverse bidding and adopted by the Commission, payable to the TSP as per Sharing Regulations;

**“Transmission License”** shall mean the license granted by the Commission in terms of the relevant regulations for grant of such license issued under the Electricity Act;

**“Transmission Service”** shall mean making the Project available as per the terms and conditions of this Agreement and Sharing Regulations;

**“Unscheduled Outage”** shall mean an interruption resulting in reduction of the Availability of the Element(s) / Project (as the case may be) that is not a result of a Scheduled Outage or a Force Majeure Event.

**“Ultimate Parent Company”** shall mean an entity which owns at least twenty six percent (26%) equity in the Bidding Company or Member of a Consortium, (as the case may be) and in the Technically Evaluated Entity and / or Financially Evaluated Entity (as the case may be) and such Bidding Company or Member of a Consortium, (as the case may be) and the Technically Evaluated Entity and / or Financially Evaluated Entity (as the case may be) shall be under the direct control or indirectly under the common control of such entity;

## 1.2 Interpretation:

***Save where the contrary is indicated, any reference in this Agreement to:***

**“Agreement”** shall be construed as including a reference to its Schedules, Appendices and Annexures;

**“Rupee”, “Rupees” and “Rs.”** shall denote lawful currency of India;

**“crore”** shall mean a reference to ten million (10,000,000) and a **“lakh”** shall mean a reference to one tenth of a million (1,00,000);

**“encumbrance”** shall be construed as a reference to a mortgage, charge, pledge, lien or other encumbrance securing any obligation of any person or any other type of preferential arrangement (including, without limitation, title transfer and retention arrangements) having a similar effect;

**“holding company”** of a company or corporation shall be construed as a reference to any company or corporation of which the other company or corporation is a subsidiary;

**"indebtedness"** shall be construed so as to include any obligation (whether incurred as principal or surety) for the payment or repayment of money, whether present or future, actual or contingent;

**"person"** shall have the meaning as defined in Section 2 (49) of the Act;

**"subsidiary"** of a company or corporation (the holding company) shall be construed as a reference to any company or corporation:

- (i) which is controlled, directly or indirectly, by the holding company, or
- (ii) more than half of the issued share capital of which is beneficially owned, directly or indirectly, by the holding company, or
- (iii) which is a subsidiary of another subsidiary of the holding company,

for these purposes, a company or corporation shall be treated as being controlled by another if that other company or corporation is able to direct its affairs and/or to control the composition of its board of directors or equivalent body;

**"winding-up", "dissolution", "insolvency", or "reorganization"** in the context of a company or corporation shall have the same meaning as defined in the Companies Act, 1956/ Companies Act, 2013 (as the case may be).

- 1.2.1 Words importing the singular shall include the plural and vice versa.
- 1.2.2 This Agreement itself or any other agreement or document shall be construed as a reference to this or to such other agreement or document as it may have been, or may from time to time be, amended, varied, novated, replaced or supplemented.
- 1.2.3 A Law shall be construed as a reference to such Law including its amendments or re-enactments from time to time.
- 1.2.4 A time of day shall, save as otherwise provided in any agreement or document be construed as a reference to Indian Standard Time.
- 1.2.5 Different parts of this Agreement are to be taken as mutually explanatory and supplementary to each other and if there is any inconsistency between or among the parts of this Agreement, they shall be interpreted in a harmonious manner so as to give effect to each part.

- 1.2.6 The tables of contents and any headings or sub-headings in this Agreement have been inserted for ease of reference only and shall not affect the interpretation of this Agreement.
- 1.2.7 All interest payable under this Agreement shall accrue from day to day and be calculated on the basis of a year of three hundred and sixty five (365) days.
- 1.2.8 The words “hereof” or “herein”, if and when used in this Agreement shall mean a reference to this Agreement.
- 1.2.9 The contents of Schedule 7 shall be referred to for ascertaining accuracy and correctness of the representations made by the Selected Bidder in Article 17.2.1 hereof.

**ARTICLE: 2**

**2 EFFECTIVENESS AND TERM OF AGREEMENT**

**2.1 Effective Date:**

This Agreement shall be effective from later of the dates of the following events:

- a. The Selected Bidder, on behalf of the TSP, has provided the Contract Performance Guarantee, as per terms of Article 3.1 of this Agreement; and
- b. The Selected Bidder has acquired for the Acquisition Price, one hundred percent (100%) of the equity shareholding of REC Power Development and Consultancy Limited in .....(Insert name of the SPV), along with all its related assets and liabilities as per the provisions of the Share Purchase Agreement. and
- c. The Agreement is executed and delivered by the Parties;

**2.2 Term and Termination:**

2.2.1 Subject to Article 2.2.3 and Article 2.4, this Agreement shall continue to be effective in relation to the Project until the Expiry Date, when it shall automatically terminate.

2.2.2 Post the Expiry Date of this Agreement, the TSP shall ensure transfer of Project Assets to CTU or its successors or an agency as decided by the Central Government at zero cost and free from any encumbrance and liability. The transfer shall be completed within 90 days of expiry of this Agreement failing which CTU shall be entitled to take over the Project Assets Suo moto.

2.2.3 This Agreement shall terminate before the Expiry Date in accordance with Article 13 or Article 3.3.2 or Article 3.3.4.

**2.3 Conditions prior to the expiry of the Transmission License**

2.3.1 In order to continue the Project beyond the expiry of the Transmission License, the TSP shall be obligated to make an application to the Commission at least two (2) years before the date of expiry of the Transmission License, seeking the Commission's approval for the extension of the term of the Transmission License up to the Expiry Date.

- 2.3.2 The TSP shall timely comply with all the requirements that may be laid down by the Commission for extension of the term of the Transmission License beyond the initial term of twenty-five (25) years & upto the Expiry Date and the TSP shall keep the Nodal Agency fully informed about the progress on its application for extension of the term of the Transmission License.

**2.4 Survival:**

The expiry or termination of this Agreement shall not affect any accrued rights, obligations/ roles and liabilities of the Parties under this Agreement, including the right to receive liquidated damages as per the terms of this Agreement, nor shall it effect the survival of any continuing obligations/ roles for which this Agreement provides, either expressly or by necessary implication, which are to survive after the Expiry Date or termination including those under Articles 3.3.3, 3.3.5, Article 9.3 (Application of Insurance Proceeds), Article 11 (Force Majeure), Article 13 (Events of Default and Termination), Article 14 (Liability & Indemnification), Article 16 (Governing Law & Dispute Resolution), Article 19 (Miscellaneous).

**2.5 Applicability of the provisions of this Agreement**

- 2.5.1 For the purpose of Availability, Target Availability and the computation of Availability, Incentive, Penalty, the provisions provided in this Agreement shall apply and any future modifications in the relevant Rules and Regulations shall not be applicable for this Project.
- 2.5.2 For the purposes of this Agreement for ISTS systems developed under the tariff based competitive bidding framework, the provisions relating to the definitions (Availability and COD), Article 3 (Contract Performance Guarantee and Conditions Subsequent), Article 5 (Construction of the Project), Article 6 (Connection and Commissioning of the Project), Article 8 (Target Availability and calculation of Availability), Article 11 (Force Majeure), Article 12 (Change in Law), Article 13 (Event of Default), Article 14 (Indemnification), Article 15 (Assignment and Charges), Articles 16.1, 16.2 and 16.4 (Governing Laws and Dispute Resolution) and Article 17 (representation and warranties of the ISTS Licensee) of this agreement shall supersede the corresponding provisions under Sharing Regulations.

**ARTICLE: 3**

**3 CONDITIONS SUBSEQUENT**

**3.1 Satisfaction of conditions subsequent by the TSP**

3.1.1 Within ten (10) days from the date of issue of Letter of Intent, the Selected Bidder, shall:

- a. Provide the Contract Performance Guarantee, and
- b. Acquire, for the Acquisition Price, one hundred percent (100%) equity shareholding of .....(Insert name of the SPV), from REC Power Development and Consultancy Limited, who shall sell to the Selected Bidder, the equity shareholding of .....(Insert name of the SPV), along with all its related assets and liabilities.
- c. Execute this Agreement;

The TSP shall, within five (5) working days from the date of acquisition of SPV by the Selected Bidder, undertake to apply to the Commission for the grant of Transmission License and for the adoption of tariff as required under section-63 of the Electricity Act.

The Selected Bidder, on behalf of the TSP, will provide to the Central Transmission Utility of India Limited (being the Nodal Agency) the Contract Performance Guarantee for an amount of **Rs. 43.50 Crore (Rupees Forty Three Crore and Fifty Lakhs Only)**.

3.1.2 The Contract Performance Guarantee shall be initially valid for a period up to three (3) months after the Scheduled COD of the Project and shall be extended from time to time to be valid for a period up to three (3) months after the COD of the Project. In case the validity of the Contract Performance Guarantee is expiring before the validity specified in this Article, the TSP shall, at least thirty (30) days before the expiry of the Contract Performance Guarantee, replace the Contract Performance Guarantee with another Contract Performance Guarantee or extend the validity of the existing Contract Performance Guarantee until the validity period specified in this Article.

3.1.3 The TSP agrees and undertakes to duly perform and complete the following activities within six (6) months from the Effective Date (except for c) below), unless such completion is affected due to any Force Majeure Event, or if any of the activities is specifically waived in writing by the Nodal Agency:

- a. To obtain the Transmission License for the Project from the Commission;
- b. To obtain the order for adoption of Transmission Charges by the Commission, as required under Section 63 of the Electricity Act 2003;
- c. To submit to the Nodal Agency, CEA & Independent Engineer, the Project Execution Plan, immediately after award of contract(s) and maximum within one hundred and twenty (120) days from the Effective Date. Also, an approved copy each of Manufacturing Quality Plan (MQP) and Field Quality Plan (FQP) would be submitted to Independent Engineer & Nodal Agency in the same time period. The TSP's Project Execution Plan should be in conformity with the Scheduled COD as specified in Schedule 2 of this Agreement, and shall bring out clearly the organization structure, time plan and methodology for executing the Project, award of major contracts, designing, engineering, procurement, shipping, construction, testing and commissioning to commercial operation;
- d. To submit to the Nodal Agency, CEA & Independent Engineer a detailed bar (GANTT) chart of the Project outlining each activity (taking longer than one Month), linkages as well as durations;
- e. To submit to the Nodal Agency, CEA & Independent Engineer detailed specifications of conductor meeting the functional specifications specified in RFP;
- f. To achieve Financial Closure;
- g. To provide an irrevocable letter to the Lenders duly accepting and acknowledging the rights provided to the Lenders under the provisions of Article 15.3 of this Agreement and all other RFP Project Documents;
- h. To award the Engineering, Procurement and Construction contract ("EPC contract") for the design and construction of the Project and shall have given to such Contractor an irrevocable notice to proceed; and
- i. To sign the Agreement(s) required, if any, under Sharing Regulations.

### **3.2 Recognition of Lenders' Rights by the Nodal Agency**

- 3.2.1 The Nodal Agency hereby accepts and acknowledges the rights provided to the Lenders as per Article 15.3 of this Agreement and all other RFP Project Documents.

### **3.3 Consequences of non-fulfilment of conditions subsequent**

3.3.1 If any of the conditions specified in Article 3.1.3 is not duly fulfilled by the TSP even within three (3) Months after the time specified therein, then on and from the expiry of such period and until the TSP has satisfied all the conditions specified in Article 3.1.3, the TSP shall, on a monthly basis, be liable to furnish to Central Transmission Utility of India Limited (being the Nodal Agency) additional Contract Performance Guarantee of **Rupees Four Crore and Thirty Five Lakh Only (Rs. 4.35 Crore)** within two (2) Business Days of expiry of every such Month. Such additional Contract Performance Guarantee shall be provided to Central Transmission Utility of India Limited (being the Nodal Agency) in the manner provided in Article 3.1.1 and shall become part of the Contract Performance Guarantee and all the provisions of this Agreement shall be construed accordingly. Central Transmission Utility of India Limited (being the Nodal Agency) shall be entitled to hold and / or invoke the Contract Performance Guarantee, including such additional Contract Performance Guarantee, in accordance with the provisions of this Agreement.

3.3.2 Subject to Article 3.3.4, if:

- (i) the fulfilment of any of the conditions specified in Article 3.1.3 is delayed beyond nine (9) Months from the Effective Date and the TSP fails to furnish additional Contract Performance Guarantee to the Nodal Agency in accordance with Article 3.3.1 hereof; or
- (ii) the TSP furnishes additional Performance Guarantee to the Nodal Agency in accordance with Article 3.3.1 hereof but fails to fulfil the conditions specified in Article 3.1.3 within a period of twelve (12) months from the Effective Date,

the Nodal Agency shall have the right to terminate this Agreement, by giving a Termination Notice to the TSP, in writing, of at least seven (7) days, with a copy to CEA and the Lenders' Representative in order to enable the Lenders to exercise right of substitution in accordance with Article 15.3 of this Agreement.

3.3.3 If the Nodal Agency elects to terminate this Agreement as per the provisions of Article 3.3.2, the TSP shall be liable to pay to the Nodal Agency an amount of **Rs. 43.50 Crore (Rupees Forty Three Crore and Fifty Lakhs Only)** as liquidated damages. The Nodal Agency shall be entitled to recover this amount of damages by invoking the Contract

Performance Guarantee to the extent of liquidated damages, which shall be required by the Nodal Agency, and the balance shall be returned to TSP, if any.

It is clarified for removal of doubt that this Article shall survive the termination of this Agreement.

- 3.3.4 In case of inability of the TSP to fulfil the conditions specified in Article 3.1.3 due to any Force Majeure Event, the time period for fulfilment of the condition subsequent as mentioned in Article 3.1.3, may be extended for a period of such Force Majeure Event. Alternatively, if deemed necessary, this Agreement may be terminated by the Nodal Agency by giving a Termination Notice to the TSP, in writing, of at least seven (7) days, with a copy to CEA and the Lenders' Representative in order to enable the Lenders to exercise right of substitution in accordance with Article 15.3 of this Agreement and the Contract Performance Guarantee shall be returned as per the provisions of Article 6.5.1.

Provided, that due to the provisions of this Article 3.3.4, any increase in the time period for completion of conditions subsequent mentioned under Article 3.1.3, shall lead to an equal increase in the time period for the Scheduled COD. If the Scheduled COD is extended beyond a period of one hundred eighty (180) days due to the provisions of this Article 3.3.4, the TSP will be allowed to recover the interest cost during construction corresponding to the period exceeding one hundred eighty (180) days by adjustment in the Transmission Charges in accordance with Schedule 9.

- 3.3.5 Upon termination of this Agreement as per Articles 3.3.2 and 3.3.4, the Nodal Agency may take steps to bid out the Project again.
- 3.3.6 The Nodal agency, on the failure of the TSP to fulfil its obligations, if it considers that there are sufficient grounds for so doing, apart from invoking the Contract Performance Guarantee under para 3.3.3 may also initiate proceedings for blacklisting the TSP as per provisions of Article 13.2 of TSA.

### **3.4 Progress Reports**

The TSP shall notify the Nodal Agency and CEA in writing at least once a Month on the progress made in satisfying the conditions subsequent in Article 3.1.3.

**ARTICLE: 4**

**4 DEVELOPMENT OF THE PROJECT**

**4.1 TSP's obligations in development of the Project:**

Subject to the terms and conditions of this Agreement, the TSP at its own cost and expense shall observe, comply with, perform, undertake and be responsible:

- a. for procuring and maintaining in full force and effect all Consents, Clearances and Permits, required in accordance with Law for development of the Project;
- b. for financing, constructing, owning and commissioning each of the Element of the Project for the scope of work set out in Schedule 1 of this Agreement in accordance with:
  - i. the Electricity Act and the Rules made thereof;
  - ii. the Grid Code;
  - iii. the CEA Regulations applicable, and as amended from time to time, for Transmission Lines and sub-stations:
    - the Central Electricity Authority (Technical Standards for Connectivity to the Grid) Regulations, 2007;
    - Central Electricity Authority (Technical Standards for construction of Electrical Plants and Electric Lines) Regulation, 2010;
    - Central Electricity Authority (Grid Standard) Regulations, 2010;
    - Central Electricity Authority (Safety requirements for construction, operation and maintenance of Electrical Plants and Electrical Lines) Regulation, 2011;
    - Central Electricity Authority (Measures relating to Safety and Electricity Supply) Regulation, 2010;
    - Central Electricity Authority (Technical Standards for Communication System in Power System Operation) Regulations, 2020.
  - iv. Safety/ security Guidelines laid down by the Government;

v. Prudent Utility Practices, relevant Indian Standards and the Law;

not later than the Scheduled COD as per Schedule 2 of this Agreement;

- c. for entering into a Connection Agreement with the concerned parties in accordance with the Grid Code.
- d. for owning the Project throughout the term of this Agreement free and clear of any encumbrances except those expressly permitted under Article 15 of this Agreement;
- e. to co-ordinate and liaise with concerned agencies and provide on a timely basis relevant information with regard to the specifications of the Project that may be required for interconnecting the Project with the Interconnection Facilities;
- f. for providing all assistance to the Arbitrators as they may require for the performance of their duties and responsibilities;
- g. to provide to the Nodal Agency and CEA, on a monthly basis, progress reports with regard to the Project and its execution (in accordance with prescribed form) to enable the CEA to monitor and co-ordinate the development of the Project matching with the Interconnection Facilities;
- h. to comply with Ministry of Power order no. 25-11/6/2018 – PG dated 02.07.2020 as well as other Guidelines issued by Govt. of India pertaining to this;
- i. to procure the products associated with the Transmission System as per provisions of Public Procurement (Preference to Make in India) orders issued by Ministry of Power vide orders No. A-1/2021- FSC- Part(5) dated 16.11.2021 and No.: P45021/2/2017-PP (BE-II)-Part-4 Vol.II dated 19.07.2024 issued by Ministry of Power for transmission sector, as amended from time to time read with Department for Promotion of Industry and Internal Trade (DPIIT) orders in this regard (Procuring Entity as defined in above orders shall deemed to have included Selected Bidder and/ or TSP).

Also, to comply with Department of Expenditure, Ministry of Finance vide Order (Public Procurement No 1) bearing File No. 6/18/2019-PPD dated 23.07.2020, Order (Public Procurement No 2) bearing File No. 6/18/2019-PPD dated 23.07.2020 and Order (Public Procurement No. 3) bearing File

No. 6/18/2019-PPD, dated 24.07.2020, Office Memorandum (OM) No. F.18/37/2020-PPD dated 08.02.2021, OM No. F.12/1/2021- P P D (Pt.) dated 02.03.2021, OM No. F.7/10/2021-PPD dated 08.06.2021 and Order (Public Procurement No 4) bearing File No. F.7/10/2021- PPD dated 23.02.2023 as amended from time to time, regarding public procurement from a bidder of a country, which shares land border with India;

- j. to submit to Nodal Agency information in the prescribed format [To be devised by Nodal Agency] for ensuring compliance to Article 4.1 i) above.
- k. to comply with all its obligations undertaken in this Agreement.

#### **4.2 Roles of the Nodal Agency in implementation of the Project:**

4.2.1 Subject to the terms and conditions of this Agreement, the Nodal Agency shall be the holder and administrator of this Agreement and shall inter alia:

- a. appoint an Independent Engineer within 90 days of the Effective Date
- b. provide letters of recommendation to the concerned Indian Governmental Instrumentality, as may be requested by the TSP from time to time, for obtaining the Consents, Clearances and Permits required for the Project;
- c. coordinate among TSP and upstream/downstream entities in respect of Interconnection Facilities; and
- d. monitor the implementation of the Agreement and take appropriate action for breach thereof including revocation of guarantees, cancellation of Agreement, blacklisting etc
- e. provide all assistance to the Arbitrators as required for the performance of their duties and responsibilities; and
- f. perform any other responsibility (ies) as specified in this Agreement.

#### **4.3 Time for Commencement and Completion:**

- a. The TSP shall take all necessary steps to commence work on the Project from the Effective Date of the Agreement and shall achieve Scheduled COD of the Project in accordance with the time schedule specified in Schedule 2 of this Agreement;

- b. The COD of each Element of the Project shall occur no later than the Scheduled COD or within such extended time to which the TSP shall be entitled under Article 4.4 hereto.

**4.4 Extension of time:**

- 4.4.1 In the event that the TSP is unable to perform its obligations for the reasons solely attributable to the Nodal Agency, the Scheduled COD shall be extended, by a 'day to day' basis, subject to the provisions of Article 13.
- 4.4.2 In the event that an Element or the Project cannot be commissioned by its Scheduled COD on account of any Force Majeure Event as per Article 11, the Scheduled COD shall be extended, by a 'day to day' basis for a period of such Force Majeure Event. Alternatively, if deemed necessary, the Nodal Agency may terminate the Agreement as per the provisions of Article 13.4 by giving a Termination Notice to the TSP, in writing, of at least seven (7) days, with a copy to CEA and the Lenders' Representative in order to enable the Lenders to exercise right of substitution in accordance with Article 15.3 of this Agreement.
- 4.4.3 If the Parties have not agreed, within thirty (30) days after the affected Party's performance has ceased to be affected by the relevant circumstance, on how long the Scheduled COD should be deferred by, any Party may raise the Dispute to be resolved in accordance with Article 16.

**4.5 Metering Arrangements:**

- 4.5.1 The TSP shall comply with all the provisions of the IEGC and the Central Electricity Authority (Installation and Operation of Meters) Regulations, 2006 as amended from time to time, with regard to the metering arrangements for the Project. The TSP shall fully cooperate with the CTU / STU / RLDC and extend all necessary assistance in taking meter readings.

**4.6 Interconnection Facilities:**

- 4.6.1 Subject to the terms and conditions of this Agreement, the TSP shall be responsible for connecting the Project with the interconnection point(s) specified in Schedule 1 of this Agreement. The Interconnection Facilities shall be developed as per the scope of work and responsibilities assigned in Schedule 1 of this Agreement. The Nodal Agency shall be responsible for coordinating to make available the Interconnection Facilities.

- 4.6.2 In order to remove any doubts, it is made clear that the obligation of the TSP within the scope of the project is to construct the Project as per Schedule-1 of this Agreement and in particular to connect it to the Interconnection Facilities as specified in this Agreement.

**ARTICLE: 5**

**5 CONSTRUCTION OF THE PROJECT**

**5.1 TSP's Construction Responsibilities:**

- 5.1.1 The TSP, at its own cost and expense, shall be responsible for designing, constructing, erecting, testing and commissioning each Element of the Project by the Scheduled COD in accordance with the Regulations and other applicable Laws specified in Article 4.1 of this Agreement.
- 5.1.2 The TSP acknowledges and agrees that it shall not be relieved from any of its obligations under this Agreement or be entitled to any extension of time or any compensation whatsoever by reason of the unsuitability of the Site or Transmission Line route(s).
- 5.1.3 The TSP shall be responsible for obtaining all Consents, Clearances and Permits related but not limited to road / rail / river / canal / power line / crossings, Power and Telecom Coordination Committee (PTCC), defence, civil aviation, right of way / way-leaves and environmental & forest clearances from relevant authorities required for developing, financing, constructing, maintaining/ renewing all such Consents, Clearances and Permits in order to carry out its obligations under this Agreement in general and shall furnish to the Nodal Agency such copy/ies of each Consents, Clearances and Permits, on demand. Nodal Agency shall provide letters of recommendation to the concerned Indian Governmental Instrumentality, as may be requested by the TSP from time to time, for obtaining the Consents, Clearances and Permits required for the Project.
- 5.1.4 The TSP shall be responsible for:
- (a) deleted.
  - (b) deleted;
  - (c) survey and geo-technical investigation of line route in order to determine the final route of the Transmission Lines;
  - (d) seeking access to the Site and other places where the Project is being executed, at its own risk and costs, including payment of any crop, tree compensation or any other compensation as may be required.
- 5.1.5 In case the Project involves any resettlement and rehabilitation, the resettlement and rehabilitation package will be implemented by the State

Government authorities, for which the costs is to be borne by the TSP and no changes would be allowed in the Transmission Charges on account of any variation in the resettlement and rehabilitation cost. The TSP shall provide assistance on best endeavour basis, in implementation of the resettlement and rehabilitation package, if execution of such package is in the interest of expeditious implementation of the Project and is beneficial to the Project affected persons

**5.2 Appointing Contractors:**

- 5.2.1 The TSP shall conform to the requirements as provided in this Agreement while appointing Contractor(s) for procurement of goods & services.
- 5.2.2 The appointment of such Contractor(s) shall neither relieve the TSP of any of its obligations under this Agreement nor make the Nodal Agency liable for the performance of such Contractor(s).

**5.3 Monthly Progress Reporting:**

The TSP shall provide to the CEA, Nodal Agency & Independent Engineer, on a monthly basis, progress reports along with likely completion date of each Element with regard to the Project and its execution (in accordance with prescribed form). The Nodal Agency/ CEA shall monitor the development of the Project for its timely completion for improving and augmenting the electricity system as a part of its statutory responsibility.

**5.4 Quality of Workmanship:**

The TSP shall ensure that the Project is designed, built and completed in a good workmanship using sound engineering and construction practices, and using only materials and equipment that are new and manufactured as per the MQP and following approved FQP for erection, testing & commissioning and complying with Indian /International Standards such that, the useful life of the Project will be at least thirty five (35) years from the COD of the Project.

The TSP shall ensure that all major substation equipment / component (e.g. transformers, reactors, Circuit Breakers, Instrument Transformers (IT), Surge Arresters (SA), Protection relays, clamps & connectors etc.), equipment in terminal stations of HVDC installations including Thyristor/ IGBT valves, Converter Transformers, smoothing reactors, Transformer bushings and wall bushings, GIS bus ducts, towers and gantry structures and transmission towers or poles and line materials (conductors, earthwire, OPGW, insulator, accessories for conductors, OPGW & earthwires, hardware fittings for insulators, aviation lights etc), facilities and system shall be designed, constructed and tested (Type test, Routine tests, Factory Acceptance Test (FAT)) in accordance with relevant CEA Regulations and Indian Standards. In case Indian Standards for any particular equipment/ system/ process is not available, IEC/ IEEE or equivalent International Standards and Codes shall be followed.

**5.5 Progress Monitoring & Quality Assurance:**

- 5.5.1 The Project Execution Plan submitted by the TSP in accordance with Article 3.1.3 c) shall comprise of detailed schedule of all the equipments/items /materials required for the Project, right from procurement of raw material till the dispatch from works and receipt at the site. Further, it should also include various stages of the construction schedule up to the commissioning of the Project.
- 5.5.2 Nodal Agency, CEA & Independent Engineer shall have access at all reasonable times to the Site and to the Manufacturer's works and to all such places where the Project is being executed.
- 5.5.3 Independent Engineer shall ensure conformity of the conductor specifications with the functional specifications specified in RFP.
- 5.5.4 The Independent Engineer shall monitor the following during construction of the Project:
- a) Quality of equipments, material, foundation, structures and workmanship etc. as laid down in Articles 5.4 and 6.1.4 of the TSA. Specifically, quality of Sub-station equipments, transmission line material and workmanship etc. would be checked in accordance with the Article 5.4.
  - b) Progress in the activities specified in Condition Subsequent
  - c) Verification of readiness of the elements including the statutory clearances & completion of civil works, fixing of all components and finalisation of punch points (if any) prior to charging of the elements
  - d) Progress of construction of substation and Transmission Lines
- 5.5.5 The progress shall be reviewed by the Independent Engineer against the Project Execution Plan. The Independent Engineer shall prepare its report on monthly basis and submit the same to Nodal Agency highlighting the progress achieved till the end of respective month vis-à-vis milestone activities, areas of concern, if any, which may result in delay in the timely completion of the Project. Based on the progress, Nodal Agency and/ or CEA shall issue written instructions to the TSP to take corrective measures, as may be prudent for the timely completion of the Project. In case of any deficiency, the Nodal Agency would be at liberty to take action in accordance with the procedure of this Agreement.

5.5.6 For any delay in commissioning any critical Element(s), as identified in Schedule 1 & Schedule 2 of this Agreement, beyond a period of 45 days shall lead to a sequestration of 10% of the Contract Performance Guarantee.

**5.6 Site regulations and Construction Documents**

The TSP shall abide by the Safety Rules and Procedures as mentioned in Schedule 3 of this Agreement

The TSP shall retain at the Site and make available for inspection at all reasonable times, copies of the Consents, Clearances and Permits, construction drawings and other documents related to construction.

**5.7 Supervision of work:**

The TSP shall provide all necessary superintendence for execution of the Project and its supervisory personnel shall be available to provide full-time superintendence for execution of the Project. The TSP shall provide skilled personnel who are experienced in their respective fields.

**5.8 Remedial Measures:**

The TSP shall take all necessary actions for remedying the shortfall in achievement of timely progress in execution of the Project, if any, as intimated by the Independent Engineer and/ or CEA and/ or the Nodal Agency. However, such intimation by the Independent Engineer and/ or CEA and/ or the Nodal Agency and the subsequent effect of such remedial measures carried out by the TSP shall not relieve the TSP of its obligations in the Agreement. Independent Engineer and/ or CEA and/ or the Nodal Agency may carry out random inspections during the Project execution, as and when deemed necessary by it. If the shortfalls as intimated to the TSP are not remedied to the satisfaction of the CEA and/ or the Nodal Agency, this Agreement may be terminated by the Nodal Agency by giving a Termination Notice to the TSP, in writing, of at least seven (7) days, with a copy to CEA and the Lenders' Representative in order to enable the Lenders to exercise right of substitution in accordance with Article 15.3 of this Agreement.

**ARTICLE: 6**

**6 CONNECTION AND COMMISSIONING OF THE PROJECT**

**6.1 Connection with the Inter-Connection Facilities:**

- 6.1.1 The TSP shall give the RLDC(s), CTU, / STU, as the case may be, and any other agencies as required, at least sixty (60) days advance written notice of the date on which it intends to connect an Element of the Project, which date shall not be earlier than its Scheduled COD or Schedule COD extended as per Article 4.4.1 & 4.4.2 of this Agreement, unless mutually agreed to by Parties. Further, any preponing of COD of any element prior to Scheduled COD must be approved by the Nodal Agency.
- 6.1.2 The RLDC / SLDC (as the case may be) or the CTU / STU (as the case may be), for reasonable cause, including non-availability of Interconnection Facilities as per Article 4.2, can defer the connection for up to fifteen (15) days from the date notified by the TSP pursuant to Article 6.1.1, if it notifies to the TSP in writing, before the date of connection, of the reason for the deferral and when the connection is to be rescheduled. However, no such deferment on one or more occasions would be for more than an aggregate period of thirty (30) days. Further, the Scheduled COD would be extended as required, for all such deferments on “day to day” basis.
- 6.1.3 Subject to Articles 6.1.1 and 6.1.2, any Element of Project may be connected with the Interconnection Facilities when:
- a. it has been completed in accordance with this Agreement and the Connection Agreement;
  - b. it meets the Grid Code, Central Electricity Authority (Technical Standards for Connectivity to the Grid) Regulations, 2007 as amended from time to time and all other Indian legal requirements, and
  - c. The TSP has obtained the approval in writing of the Electrical Inspector certifying that the Element is ready from the point of view of safety of supply and can be connected with the Interconnection Facilities.
  - d. It has satisfactorily met all the testing requirements as per Articles 6.1.4

6.1.4 Site Acceptance Test (SAT)/ pre-commissioning tests of all major substation equipment, component, system, facilities shall be successfully carried out before commissioning. The Type tests, FAT and SAT reports should be available at the substation / terminal station of HVDC installations for ready reference of operation and maintenance staff and has to be made available to the Independent Engineer appointed for quality monitoring or their authorised representatives, as and when they wish to examine the same.

**6.2 Commercial Operation:**

6.2.1 An Element of the Project shall be declared to have achieved COD twenty four (24) hours following the connection of the Element with the Interconnection Facilities pursuant to Article 6.1 or seven (7) days after the date on which it is declared by the TSP to be ready for charging but is not able to be charged for reasons not attributable to the TSP subject to Article 6.1.2.

Provided that an Element shall be declared to have achieved COD only after all the Element(s), if any, which are pre-required to have achieved COD as defined in Schedule 2 of this Agreement, have been declared to have achieved their respective COD.

6.2.2 Once any Element of the Project has been declared to have achieved deemed COD as per Article 6.2.1 above, such Element of the Project shall be deemed to have Availability equal to the Target Availability till the actual charging of the Element and to this extent, TSP shall be eligible for the Monthly Transmission Charges applicable for such Element

**6.3 Compensation for Direct Non Natural Force Majeure Event or Indirect Non Natural Force Majeure Event or Natural Force Majeure Event (affecting the Nodal Agency)**

6.3.1 If the TSP is otherwise ready to connect the Element(s) of the Project and has given due notice, as per provisions of Article 6.1.1, to the concerned agencies of the date of intention to connect the Element(s) of the Project, where such date is not before the Scheduled COD, but is not able to connect the Element(s) of the Project by the said date specified in the notice, due to Direct Non Natural Force Majeure Event or Indirect Non Natural Force Majeure Event or Natural Force Majeure Event affecting the Nodal Agency, provided such Direct Non Natural Force Majeure Event or Indirect Non Natural Force Majeure Event or Natural

Force Majeure Event affecting the Nodal Agency has continued for a period of more than three (3) continuous or non-continuous Months, the TSP shall, until the effects of the Direct Non Natural Force Majeure Event or of Indirect Non Natural Force Majeure Event or Natural Force Majeure Event affecting the Nodal Agency no longer prevent the TSP from connecting the Element(s) of the Project, be deemed to have achieved COD relevant to that date and to this extent, be deemed to have been providing Transmission Service with effect from the date notified, and shall be treated as follows:

- a. In case of delay due to Direct Non Natural Force Majeure Event, TSP is entitled for Transmission Charges calculated on Target Availability for the period of such events in excess of three (3) continuous or non continuous Months in the manner provided in (c) below.
- b. In case of delay due to Indirect Non Natural Force Majeure Event or Natural Force Majeure Event affecting the Nodal Agency, TSP is entitled for payment for debt service which is due under the Financing Agreements, subject to a maximum of Transmission Charges calculated on Target Availability, for the period of such events in excess of three (3) continuous or non continuous Months in the manner provided in (c) below.
- c. In case of delay due to Direct Non Natural Force Majeure Event or Indirect Non Natural Force Majeure Event or Natural Force Majeure Event affecting the Nodal Agency, the TSP is entitled for payments mentioned in (a) and (b) above, after commencement of Transmission Service, in the form of an increase in Transmission Charges. These amounts shall be paid from the date, being the later of a) the date of cessation of such Indirect Non Natural Force Majeure Event or Natural Force Majeure Event affecting the Nodal Agency and b) the completion of sixty (60) days from the receipt of the Financing Agreements by the Nodal Agency from the TSP.

Provided such increase in Transmission Charges shall be so as to put the TSP in the same economic position as the TSP would have been in case the TSP had been paid amounts mentioned in (a) and (b) above in a situation where the Force Majeure Event had not occurred.

For the avoidance of doubt, it is clarified that the charges payable under this Article 6.3.1 shall be recovered as per Sharing Regulations.

**6.4 Liquidated Damages for Delay in achieving COD of Project:**

6.4.1 If the TSP fails to achieve COD of any Element of the Project or the Project, by the Element's / Project's Scheduled COD or such Scheduled COD as extended under Articles 4.4.1 and 4.4.3, then the TSP shall pay to the Nodal Agency, a sum equivalent to 3.33% of Monthly Transmission Charges applicable for the Element of the Project [in case where no Elements have been defined, to be on the Project as a whole] / Project, for each day of delay up to sixty (60) days of delay and beyond that time limit, at the rate of five percent (5%) of the Monthly Transmission Charges applicable to such Element / Project, as liquidated damages for such delay and not as penalty, without prejudice to any rights of the Nodal Agency under the Agreement.

6.4.2 The TSP's maximum liability under this Article 6.4 shall be limited to the amount of liquidated damages calculated in accordance with Article 6.4.1 for and up to six (6) months of delay for the Element or the Project.

Provided that, in case of failure of the TSP to achieve COD of the Element of the Project even after the expiry of six (6) months from its Scheduled COD, the provisions of Article 13 shall apply.

6.4.3 The TSP shall make payment to the Nodal Agency of the liquidated damages calculated pursuant to Article 6.4.1 within ten (10) days of the earlier of:

- a. the date on which the applicable Element achieves COD; or
- b. the date of termination of this Agreement.

The payment of such damages shall not relieve the TSP from its obligations to complete the Project or from any other obligation and liabilities under the Agreement.

6.4.4 If the TSP fails to pay the amount of liquidated damages to the Nodal Agency within the said period of ten (10) days, the Nodal Agency shall be entitled to recover the said amount of the liquidated damages by invoking the Contract Performance Guarantee. If the then existing Contract Performance Guarantee is for an amount which is less than the amount of the liquidated damages payable by the TSP to the Nodal Agency under this Article 6.3 and the TSP fails to make payment of the balance amount of the liquidated damages not covered by the Contract Performance Guarantee, then such balance amount shall be deducted from the Transmission Charges payable to the TSP. The right of the

Nodal Agency to encash the Contract Performance Guarantee is without prejudice to the other rights of the Nodal Agency under this Agreement.

- 6.4.5 For avoidance of doubt, it is clarified that amount payable by TSP under this Article is over and above the penalty payable by TSP under Article 5.5.6 of this Agreement.

## **6.5 Return of Contract Performance Guarantee**

- 6.5.1 The Contract Performance Guarantee as submitted by TSP in accordance with Article 3.1.1 shall be released by the Nodal Agency within three (3) months from the COD of the Project. In the event of delay in achieving Scheduled COD of any of the Elements by the TSP (otherwise than due to reasons as mentioned in Article 3.1.3 or Article 11) and consequent part invocation of the Contract Performance Guarantee by the Nodal Agency, Nodal Agency shall release the Contract Performance Guarantee, if any remaining unadjusted, after the satisfactory completion by the TSP of all the requirements regarding achieving the Scheduled COD of the remaining Elements of the Project. It is clarified that the Nodal Agency shall also return / release the Contract Performance Guarantee in the event of (i) applicability of Article 3.3.2 to the extent the Contract Performance Guarantee is valid for an amount in excess of **Rs. 43.50 Crore (Rupees Forty Three Crore and Fifty Lakhs Only)**, or (ii) termination of this Agreement by the Nodal Agency as mentioned under Article 3.3.4 of this Agreement.
- 6.5.2 The release of the Contract Performance Guarantee shall be without prejudice to other rights of the Nodal Agency under this Agreement.

**ARTICLE: 7**

**7 OPERATION AND MAINTENANCE OF THE PROJECT**

**7.1 Operation and Maintenance of the Project:**

The TSP shall be responsible for ensuring that the Project is operated and maintained in accordance with the regulations made by the Commission and CEA from time to time and provisions of the Act.

**ARTICLE: 8**

**8 AVAILABILITY OF THE PROJECT**

**8.1 Calculation of Availability of the Project:**

Calculation of Availability for the Elements and for the Project, as the case may be, shall be as per Appendix –IV to Central Electricity Regulatory Commission (Terms and Conditions of Tariff) Regulations, 2024, as applicable on the Bid Deadline and as appended in Schedule 6 of this Agreement.

**8.2 Target Availability:**

The Target Availability of each Element and the Project shall be 98%.

Payment of monthly Transmission charges based on actual availability will be calculated as per para 1.2 of Schedule 4 of this Agreement.

If the availability of any Element or the Project is below the Target Availability, for six consecutive months in a Contract Year, the DIC(s) or the Nodal Agency may issue a show cause notice to the TSP, asking them to show cause as to why the Transmission Service Agreement be not terminated, and if no satisfactory cause is shown it may terminate the Agreement. If the Nodal Agency is of the opinion that the transmission system is of critical importance, it may carry out or cause to carry the operation and maintenance of transmission system at the risk and cost of TSP.

**ARTICLE: 9**

**9 INSURANCES**

**9.1 Insurance:**

9.1.1 The TSP shall effect and maintain or cause to be effected and maintained during the Construction Period and the Operating Period, adequate Insurances against such risks, with such deductibles including but not limited to any third party liability and endorsements and co-beneficiary/insured, as may be necessary under

- a. any of the Financing Agreements,
- b. the Laws, and
- c. in accordance with Prudent Utility Practices.

The Insurances shall be taken effective from a date prior to the date of the Financial Closure till the Expiry Date.

**9.2 Evidence of Insurance cover:**

9.2.1 The TSP shall furnish to the Nodal Agency copies of certificates and policies of the Insurances, as and when the Nodal Agency may seek from the TSP as per the terms of Article 9.1

**9.3 Application of Insurance Proceeds:**

9.3.1 Save as expressly provided in this Agreement, the policies of Insurances and the Financing Agreements, the proceeds of any insurance claim made due to loss or damage to the Project or any part of the Project shall be first applied to reinstatement, replacement or renewal of such loss or damage.

9.3.2 If a Natural Force Majeure Event renders the Project no longer economically and technically viable and the insurers under the Insurances make payment on a “total loss” or equivalent basis, the portion of the proceeds of such Insurance available to the TSP (after making admissible payments to the Lenders as per the Financing Agreements) shall be allocated only to the TSP. Nodal Agency and / or concerned Designated ISTS Customers shall have no claim on such proceeds of the Insurance.

9.3.3 Subject to the requirements of the Lenders under the Financing

Agreements, any dispute or difference between the Parties as to whether the Project is no longer economically and technically viable due to a Force Majeure Event or whether that event was adequately covered in accordance with this Agreement by the Insurances shall be determined in accordance with Article 16.

**9.4 Effect on liability of the Nodal Agency / Designated ISTS Customers**

9.4.1 The Nodal Agency and / or the Designated ISTS Customers shall have no financial obligations or liability whatsoever towards the TSP in respect of this Article 9.

**ARTICLE: 10**

**10 BILLING AND PAYMENT OF TRANSMISSION CHARGES**

**10.1** Subject to provisions of this Article 10, the Monthly Transmission Charges shall be paid to the TSP, in Indian Rupees, on monthly basis as per the provisions of the Sharing Regulations, from the date on which an Element(s) has achieved COD until the Expiry Date of this Agreement, unless terminated earlier and in line with the provisions of Schedule 4 of this Agreement.

**10.2 Calculation of Monthly Transmission Charges:**

The Monthly Transmission Charges for each Contract Year including Incentive & Penalty payment shall be calculated in accordance with the provisions of Schedule 4 of this Agreement.

**10.3 Rebate & Late Payment Surcharge:**

The rebate and late payment surcharge shall be governed as per Sharing Regulations.

**10.4 Disputed Bills, Default in payment by the Designated ISTS Customers & Annual Reconciliation:**

Any Disputed Bill, Default in payment by the Designated ISTS Customers & Annual Reconciliation shall be governed as per Sharing Regulations.

## **ARTICLE: 11**

### **11 FORCE MAJEURE**

#### **11.1 Definitions**

11.1.1 The following terms shall have the meanings given hereunder.

#### **11.2 Affected Party**

11.2.1 An Affected Party means any Party whose performance has been affected by an event of Force Majeure.

11.2.2 Any event of Force Majeure shall be deemed to be an event of Force Majeure affecting the TSP only if the Force Majeure event affects and results in, late delivery of machinery and equipment for the Project or construction, completion, commissioning of the Project by Scheduled COD and/or operation thereafter;

#### **11.3 Force Majeure**

A 'Force Majeure' means any event or circumstance or combination of events and circumstances including those stated below that wholly or partly prevents or unavoidably delays an Affected Party in the performance of its obligations/ roles under this Agreement, but only if and to the extent that such events or circumstances are not within the reasonable control, directly or indirectly, of the Affected Party and could not have been avoided if the Affected Party had taken reasonable care or complied with Prudent Utility Practices:

##### **(a) Natural Force Majeure Events:**

- i. act of God, including, but not limited to drought, fire and explosion (to the extent originating from a source external to the Site), earthquake, volcanic eruption, landslide, flood, cyclone, typhoon, tornado, or exceptionally adverse weather conditions, which are in excess of the statistical measures for the last hundred (100) years; and
- ii. epidemic/ pandemic notified by Indian Governmental Instrumentality.

##### **(b) Non-Natural Force Majeure Events :**

- i. Direct Non-Natural Force Majeure Events

- Nationalization or compulsory acquisition by any Indian Governmental Instrumentality of any material assets or rights of the Affected Party; or
- the unlawful, unreasonable or discriminatory revocation of, or refusal to renew, any Consents, Clearances and Permits required by the Affected Party to perform their obligations/ roles under the RFP Project Documents or any unlawful, unreasonable or discriminatory refusal to grant any other Consents, Clearances and Permits required for the development/ operation of the Project, provided that a Competent Court of Law declares the revocation or refusal to be unlawful, unreasonable and discriminatory and strikes the same down; or
- any other unlawful, unreasonable or discriminatory action on the part of an Indian Governmental Instrumentality which is directed against the Project, provided that a Competent Court of Law declares the action to be unlawful, unreasonable and discriminatory and strikes the same down.

ii. Indirect Non - Natural Force Majeure Events

- act of war (whether declared or undeclared), invasion, armed conflict or act of foreign enemy, blockade, embargo, revolution, riot, insurrection, terrorist or military action; or
- radio active contamination or ionising radiation originating from a source in India or resulting from any other Indirect Non Natural Force Majeure Event mentioned above, excluding circumstances where the source or cause of contamination or radiation is brought or has been brought into or near the Site by the Affected Party or those employed or engaged by the Affected Party; or
- industry-wide strikes and labour disturbances, having a nationwide impact in India.

## **11.4 Force Majeure Exclusions**

- 11.4.1 Force Majeure shall not include (i) any event or circumstance which is within the reasonable control of the Parties and (ii) the following conditions, except to the extent that they are consequences of an event of Force Majeure:

- (a) Unavailability, late delivery, or changes in cost of the machinery, equipment, materials, spare parts etc. for the Project;
- (b) Delay in the performance of any Contractors or their agents;
- (c) Non-performance resulting from normal wear and tear typically experienced in transmission materials and equipment;
- (d) Strikes or labour disturbance at the facilities of the Affected Party;
- (e) Insufficiency of finances or funds or the Agreement becoming onerous to perform; and
- (f) Non-performance caused by, or connected with, the Affected Party's:
  - i. negligent or intentional acts, errors or omissions;
  - ii. failure to comply with an Indian Law; or
  - iii. breach of, or default under this Agreement or any Project Documents.
- (g) Any error or omission in the survey report provided by BPC during the bidding process.

## **11.5 Notification of Force Majeure Event**

- 11.5.1 The Affected Party shall give notice to the other Party of any event of Force Majeure as soon as reasonably practicable, but not later than seven (7) days after the date on which such Party knew or should reasonably have known of the commencement of the event of Force Majeure. If an event of Force Majeure results in a breakdown of communications rendering it unreasonable to give notice within the applicable time limit specified herein, then the Party claiming Force Majeure shall give such notice as soon as reasonably practicable after reinstatement of communications, but not later than one (1) day after such reinstatement.

Provided that, such notice shall be a pre-condition to the Affected Party's entitlement to claim relief under this Agreement. Such notice shall include full particulars of the event of Force Majeure, its effects on the Party claiming relief and the remedial measures proposed. The Affected Party shall give the other Party regular reports on the progress of those remedial measures and such other information as the other Party may reasonably request about the Force Majeure.

11.5.2 The Affected Party shall give notice to the other Party of (i) the cessation of the relevant event of Force Majeure; and (ii) the cessation of the effects of such event of Force Majeure on the performance of its rights or obligations/ roles under this Agreement, as soon as practicable after becoming aware of each of these cessations.

#### **11.6 Duty to perform and duty to mitigate**

To the extent not prevented by a Force Majeure Event, the Affected Party shall continue to perform its obligations/ roles as provided in this Agreement. The Affected Party shall use its reasonable efforts to mitigate the effect of any event of Force Majeure as soon as practicable.

#### **11.7 Available Relief for a Force Majeure Event**

Subject to this Article 11,

- (a) no Party shall be in breach of its obligations/ roles pursuant to this Agreement to the extent that the performance of its obligations/ roles was prevented, hindered or delayed due to a Force Majeure Event;
- (b) each Party shall be entitled to claim relief for a Force Majeure Event affecting its performance in relation to its obligations/ roles under Articles 3.3.4, 4.4.2 and 6.3.1 of this Agreement.
- (c) For the avoidance of doubt, it is clarified that the computation of Availability of the Element(s) under outage due to Force Majeure Event, as per Article 11.3 affecting the TSP shall be as per Appendix –IV to Central Electricity Regulatory Commission (Terms and Conditions of Tariff) Regulations, 2024 as on Bid Deadline. For the event(s) for which the Element(s) is/are deemed to be available as per Appendix –IV to Central Electricity Regulatory Commission (Terms and Conditions of Tariff) Regulations, 2024, then the Transmission Charges, as applicable to such Element(s), shall be payable as per Schedule 4, for the duration of such event(s).
- (d) For so long as the TSP is claiming relief due to any Force Majeure Event under this Agreement, the Nodal Agency may, if it so desires, from time to time on one (1) day notice, inspect the Project and the TSP shall provide the Nodal Agency's personnel with access to the Project to carry out such inspections.
- (e) For avoidance of doubt, the TSP acknowledges that for extension of Scheduled COD a period up to one hundred eighty (180) days due to

Force Majeure event, no compensation on the grounds such as interest cost, incident expenditure, opportunity cost will be made to the TSP. However, if Scheduled COD is extended beyond a period of one hundred eighty (180) days due to Force Majeure event, the TSP will be allowed to recover the interest cost during construction corresponding to the period exceeding one hundred eighty (180) days by adjustment in the Transmission Charges in accordance with Schedule 9.

**ARTICLE: 12**

**12 CHANGE IN LAW**

**12.1 Change in Law**

12.1.1 Change in Law means the occurrence of any of the following after the Bid Deadline resulting into any additional recurring / non-recurring expenditure by the TSP or any savings of the TSP:

- the enactment, coming into effect, adoption, promulgation, amendment, modification or repeal (without re-enactment or consolidation) in India, of any Law, including rules and regulations framed pursuant to such Law, subject to the provisions under Article 12.1.2;
- a change in the interpretation or application of any Law by any Indian Governmental Instrumentality having the legal power to interpret or apply such Law, or any Competent Court of Law;
- the imposition of a requirement for obtaining any Consents, Clearances and Permits which was not required earlier;
- a change in the terms and conditions prescribed for obtaining any Consents, Clearances and Permits or the inclusion of any new terms or conditions for obtaining such Consents, Clearances and Permits;
- any change in the licensing regulations of the Commission, under which the Transmission License for the Project was granted if made applicable by such Commission to the TSP;
- change in wind zone; or
- any change in tax or introduction of any tax made applicable for providing Transmission Service by the TSP as per the terms of this Agreement.

12.1.2 Notwithstanding anything contained in this Agreement, Change in Law shall not cover any change:

- a) Taxes on corporate income; and
- b) Withholding tax on income or dividends distributed to the shareholders of the TSP.

**12.2 Relief for Change in Law**

12.2.1 During Construction Period, the impact of increase/decrease in the cost of the Project on the Transmission Charges shall be governed by the formula given in Schedule 9 of this Agreement.

12.2.2 During the Operation Period:

During the operation period, if as a result of Change in Law, the TSP suffers or is benefited from a change in costs or revenue, the aggregate financial effect of which exceeds 0.30% (zero point three percent) of the Annual Transmission Charges in aggregate for a Contract Year, the TSP may notify so to the Nodal Agency and propose amendments to this Agreement so as to place the TSP in the same financial position as it would have enjoyed had there been no such Change in Law resulting in change in costs or revenue as aforesaid.

12.2.3 For any claims made under Articles 12.2.1 and 12.2.2 above, the TSP shall provide to the Nodal Agency documentary proof of such increase / decrease in cost of the Project / revenue for establishing the impact of such Change in Law.

In cases where Change in Law results in decrease of cost and it comes to the notice of Nodal Agency that TSP has not informed Nodal Agency about such decrease in cost, Nodal Agency may initiate appropriate claim.

**12.3 Notification of Change in Law:**

- 12.3.1 If the TSP is affected by a Change in Law in accordance with Article 12.1 and wishes to claim relief for such Change in Law under this Article 12, it shall give notice to Nodal Agency of such Change in Law as soon as reasonably practicable after becoming aware of the same.
- 12.3.2 The TSP shall also be obliged to serve a notice to the Nodal Agency even when it is beneficially affected by a Change in Law.
- 12.3.3 Any notice served pursuant to Articles 12.3.1 and 12.3.2 shall provide, amongst other things, precise details of the Change in Law and its estimated impact on the TSP.

**12.4 Payment on account of Change in Law**

- 12.4.1 The payment for Change in Law shall be through a separate Bill. However, in case of any change in Monthly Transmission Charges by reason of Change in Law, as determined in accordance with this Agreement, the Bills to be raised by the Nodal Agency after such change in Transmission Charges shall appropriately reflect the changed Monthly Transmission Charges.

**ARTICLE: 13**

**13 EVENTS OF DEFAULT AND TERMINATION**

**13.1 TSP's Event of Default**

The occurrence and continuation of any of the following events shall constitute a TSP Event of Default, unless any such TSP Event of Default occurs as a result of any non-fulfilment of its obligations as prescribed under this Agreement by the Nodal Agency or a Force Majeure Event:

- a. After having taken up the construction of the Project, the abandonment by the TSP or the TSP's Contractors of the construction of the Project for a continuous period of two (2) months and such default is not rectified within thirty (30) days from the receipt of notice from the Nodal Agency in this regard;
- b. The failure to commission any Element of the Project by the date falling six (6) months after its Scheduled COD unless extended by Nodal Agency as per provisions of this Agreement;
- c. If the TSP:
  - i. assigns, mortgages or charges or purports to assign, mortgage or charge any of its assets or rights related to the Project in contravention of the provisions of this Agreement; or
  - ii. transfers or novates any of its obligations pursuant to this Agreement, in a manner contrary to the provisions of this Agreement;

Except where such transfer is in pursuance of a Law and

- it does not affect the ability of the transferee to perform, and such transferee has the financial and technical capability to perform, its obligations under this Agreement;
- is to a transferee who assumes such obligations under the Project and this Agreement remains effective with respect to the transferee;

- d. If:

- i. The TSP becomes voluntarily or involuntarily the subject of any bankruptcy or insolvency or winding up proceedings and such proceedings remain uncontested for a period of thirty (30) days; or
- ii. any winding up or bankruptcy or insolvency order is passed against the TSP; or
- iii. the TSP goes into liquidation or dissolution or a receiver or any similar officer is appointed over all or substantially all of its assets or official liquidator is appointed to manage its affairs, pursuant to Law,

Provided that a dissolution or liquidation of the TSP will not be a TSP's Event of Default, where such dissolution or liquidation of the TSP is for the purpose of a merger, consolidation or reorganization with the prior approval of the Commission as per the provisions of Central Electricity Regulatory Commission (Procedure, terms and Conditions for grant of Transmission License and other related matters) Regulations, 2006 or as amended from time to time; or

- e. Failure on the part of the TSP to comply with the provisions of Article 19.1 of this Agreement; or
- f. the TSP repudiates this Agreement and does not rectify such breach even within a period of thirty (30) days from a notice from the Nodal Agency in this regard; or
- g. after Commercial Operation Date of the Project, the TSP fails to achieve monthly Target Availability of 98%, for a period of six (6) consecutive months or within a non-consecutive period of six (6) months within any continuous aggregate period of eighteen(18) months except where the Availability is affected by Force Majeure Events as per Article 11; or
- h. any of the representations and warranties made by the TSP in Article 17 of this Agreement being found to be untrue or inaccurate. Further, in addition to the above, any of the undertakings submitted by the Selected Bidder at the time of submission of the Bid being found to be breached or inaccurate, including but not limited to undertakings from its Parent Company / Affiliates related to the minimum equity obligation; or

- i. the TSP fails to complete / fulfil all the activities / conditions within the specified period as per Article 3; or
- j. except for the reasons solely attributable to Nodal Agency, the TSP is in material breach of any of its obligations under this Agreement and such material breach is not rectified by the TSP within thirty (30) days of receipt of notice in this regard from the Nodal Agency; or
- k. deleted.

### **13.2 Termination Procedure for TSP Event of Default**

- a. Upon the occurrence and continuance of any TSP's Event of Default under Article 13.1 the Nodal Agency may serve notice on the TSP, with a copy to the CEA and the Lenders' Representative, of their intention to terminate this Agreement (a "Nodal Agency's Preliminary Termination Notice"), which shall specify in reasonable detail, the circumstances giving rise to such Nodal Agency's Preliminary Termination Notice.
- b. Following the issue of a Nodal Agency's Preliminary Termination Notice, the Consultation Period shall apply and would be for the Parties to discuss as to what steps shall be taken with a view to mitigate the consequences of the relevant Event of Default having regard to all the circumstances.
- c. During the Consultation Period, the Parties shall, save as otherwise provided in this Agreement, continue to perform their respective obligations/ roles under this Agreement, and the TSP shall not remove any material, equipment or any part of the Project, without prior consent of the Nodal Agency.

Following the expiry of the Consultation Period, unless the Parties shall have otherwise agreed to the contrary or the circumstances giving rise to Nodal Agency's Preliminary Termination Notice shall have ceased to exist or shall have been remedied, this Agreement may be terminated by the Nodal Agency by giving a Termination Notice to the TSP, in writing, of at least seven (7) days, with a copy to CEA and the Lenders' Representative in order to enable the

Lenders to exercise right of substitution in accordance with Article 15.3 of this Agreement.

Further, the Nodal Agency may also initiate proceedings to blacklist the TSP & its Affiliates from participation in any RFP issued by BPCs for a period of 5 years.

### **13.3 Procedure for Nodal Agency's non-fulfilment of Role**

- a. Upon the Nodal Agency not being able to fulfil its role under Article 4.2, the TSP may serve notice on the Nodal Agency, with a copy to CEA and the Lenders' Representative (a "TSP's Preliminary Notice"), which notice shall specify in reasonable detail the circumstances giving rise to such non-fulfilment of role by the Nodal Agency.
- b. Following the issue of a TSP's Preliminary Notice, the Consultation Period shall apply.
- c. The Consultation Period would be for the Parties to discuss as to what steps shall be taken with a view to mitigate the consequences of the relevant non-fulfilment of role by the Nodal Agency including giving time extension to TSP, having regard to all the circumstances.
- d. During the Consultation Period, both Parties shall, save as otherwise provided in this Agreement, continue to perform their respective obligations/ roles under this Agreement.

### **13.4 Termination due to Force Majeure**

- 13.4.1 In case the Parties could not reach an agreement pursuant to Articles 3.3.4 and 4.4.2 of this Agreement and the Force Majeure Event or its effects continue to be present, the Nodal Agency shall have the right to cause termination of the Agreement. In case of such termination, the Contract Performance Guarantee shall be returned to the TSP as per the provisions of Article 6.5.1.

13.4.2 In case of termination of this Agreement, the TSP shall provide to the Nodal Agency the full names and addresses of its Contractors as well as complete designs, design drawings, manufacturing drawings, material specifications and technical information, as required by the Nodal Agency within thirty (30) days of Termination Notice.

**13.5 Termination or amendment due to non-requirement of any Element or Project during construction**

13.5.1 In case any Element or Project, which is under construction, is no longer required due to any reason whatsoever, the Nodal Agency may issue a notice to this effect to the TSP.

13.5.2 Nodal agency may also issue notice to the TSP seeking their response to the proposed termination/ amendment (as the case may be) of the Agreement. The Nodal Agency shall issue copy of such notice to Lenders. In the notice, Nodal Agency shall also include an assessment of the physical progress made by TSP in the Element/ Project (as the case may be) that is no longer required.

13.5.3 The TSP shall neither carry out further investment nor carry out any work on the Element/ Project (as the case may be) that is no longer required after delivery of the notice.

13.5.4 After taking into account the comments of the TSP, the Nodal Agency may terminate the Agreement or amend it if both Parties agree to the amendment.

**13.6 Revocation of the Transmission License**

13.6.1 The Commission may, as per the provisions of the Electricity Act, 2003, revoke the Transmission License of the ISTS Licensee. Further, in such a case, the Agreement shall be deemed to have been terminated.

**13.7 Termination Payment**

13.7.1 If Agreement is terminated on account of Force Majeure Events, non-requirement of any Element or Project during Construction, Nodal Agency's non-fulfilment of Role & TSP's Event of Default, the TSP shall be entitled for Termination Payment equivalent to valuation of Project Assets. Upon payment, the Nodal Agency shall take over the Project Assets.

**ARTICLE: 14**

**14 LIABILITY AND INDEMNIFICATION**

**14.1 Indemnity**

14.1.1 The TSP shall indemnify, defend and hold the Nodal Agency harmless against:

- (a) any and all third party claims, actions, suits or proceedings against the Nodal Agency for any loss of or damage to property of such third party, or death or injury to such third party, arising out of a breach by the TSP of any of its obligations under this Agreement, except to the extent that any such claim, action, suit or proceeding has arisen due to a negligent act or omission, breach of this Agreement or non-fulfilment of statutory duty on the part of Nodal Agency; and
- (b) any and all losses, damages, costs and expenses including legal costs, fines, penalties and interest actually suffered or incurred by the Nodal Agency from third party claims arising by reason of:
  - i. a breach by the TSP of any of its obligations under this Agreement, (provided that this Article 14 shall not apply to such breaches by the TSP, for which specific remedies have been provided for under this Agreement) except to the extent that any such losses, damages, costs and expenses including legal costs, fines, penalties and interest (together to constitute "Indemnifiable Losses") has arisen due to a negligent act or omission, breach of this Agreement or non-fulfilment of statutory duty on the part of the Nodal Agency, or
  - ii. any of the representations and warranties of the TSP under this Agreement being found to be inaccurate or untrue.

14.1.2 The Nodal Agency shall, in accordance with the Regulations framed by CERC in this regard, indemnify, defend and hold the TSP harmless against:

- (a) any and all third party claims, actions, suits or proceedings against the TSP, for any loss of or damage to property of such third party, or death or injury to such third party, arising out of any material breach by the Nodal Agency of any of their roles under this Agreement, except to the extent that any such claim, action, suit or

proceeding has arisen due to a negligent act or omission, breach of this Agreement or breach of statutory duty on the part of the TSP, its Contractors, servants or agents; and

- (b) any and all losses, damages, costs and expenses including legal costs, fines, penalties and interest ('Indemnifiable Losses') actually suffered or incurred by the TSP from third party claims arising by reason of:
  - i. any material breach by the Nodal Agency of any of its roles under this Agreement (provided that, this Article 14 shall not apply to such breaches by the Nodal Agency, for which specific remedies have been provided for under this Agreement), except to the extent that any such Indemnifiable Losses have arisen due to a negligent act or omission, breach of this Agreement or breach of statutory duty on the part of the TSP, its Contractors, servants or agents or
  - ii. any of the representations and warranties of the Nodal Agency under this Agreement being found to be inaccurate or untrue.

## **14.2 Patent Indemnity:**

### **14.2.1**

- (a) The TSP shall, subject to the Nodal Agency's compliance with Article 14.2.1 (b), indemnify and hold harmless the Nodal Agency and its employees and officers from and against any and all suits, actions or administrative proceedings, claims, demands, losses, damages, costs, and expenses of whatsoever nature, including attorney's fees and expenses, which the Nodal Agency may suffer as a result of any infringement or alleged infringement of any patent, utility model, registered design, trademark, copyright or other Intellectual property right registered or otherwise existing at the date of the Agreement by reason of the setting up of the project by the TSP.

Such indemnity shall not cover any use of the Project or any part thereof other than for the purpose indicated by or to be reasonably inferred from the Agreement, any infringement resulting from the misuse of the Project or any part thereof, or any products produced in association or combination with any other equipment, plant or materials not supplied by the TSP, pursuant to the Agreement.

- (b) If any proceedings are brought or any claim is made against the Nodal Agency arising out of the matters referred to in Article 14.2.1(a), the Nodal Agency shall promptly give the TSP a notice thereof, and the TSP shall at its own expense take necessary steps and attend such proceedings or claim and any negotiations for the settlement of any such proceedings or claim. The TSP shall promptly notify the Nodal Agency of all actions taken in such proceedings or claims.
- (c) If the TSP fails to notify the Nodal Agency within twenty-eight (28) days after receipt of such notice from the Nodal Agency under Article 14.2.1(b) above, that it intends to attend any such proceedings or claim, then the Nodal Agency shall be free to attend the same on their own behalf at the cost of the TSP. Unless the TSP has so failed to notify the Nodal Agency within the twenty eight (28) days period, the Nodal Agency shall make no admission that may be prejudicial to the defence of any such proceedings or claims.
- (d) The Nodal Agency shall, at the TSP's request, afford all available assistance to the TSP in attending to such proceedings or claim, and shall be reimbursed by the TSP for all reasonable expenses incurred in so doing.

#### 14.2.2

- (a) The Nodal Agency, in accordance with the Regulations framed by CERC in this regard, subject to the TSP's compliance with Article 14.2.2(b) shall indemnify and hold harmless the TSP and its employees, officers from and against any and all suits, actions or administrative proceedings, claims, demands, losses, damages, costs and expenses of whatsoever nature, including attorney's fees and expenses, which the TSP may suffer as a result of any infringement or alleged infringement of any patent, utility model, registered design, trademark, copyright or other intellectual property right registered or otherwise existing at the date of the Agreement by reason of the setting up of the Project by the TSP
- (b) If any proceedings are brought or any claim is made against the TSP arising out of the matters referred to in Article 14.2.2 (a) the TSP shall promptly give the Nodal Agency a notice thereof, and the Nodal Agency shall at its own expense take necessary steps and attend such proceedings or claim and any negotiations for the

settlement of any such proceedings or claim. The Nodal Agency shall promptly notify the TSP of all actions taken in such proceedings or claims.

- (c) If the Nodal Agency fails to notify the TSP within twenty-eight (28) days after receipt of such notice from the TSP under Article 14.2.2(b) above, that it intends to attend any such proceedings or claim, then the TSP shall be free to attend the same on its own behalf at the cost of the Nodal Agency. Unless the Nodal Agency has so failed to notify the TSP within the twenty (28) days period, the TSP shall make no admission that may be prejudicial to the defence of any such proceedings or claim.
- (d) The TSP shall, at the Nodal Agency request, afford all available assistance to the Nodal Agency in attending to such proceedings or claim, and shall be reimbursed by the Nodal Agency for all reasonable expenses incurred in so doing.

### **14.3 Monetary Limitation of liability**

- 14.3.1 A Party ("Indemnifying Party") shall be liable to indemnify the other Party ("Indemnified Party") under this Article 14 for any indemnity claims made in a Contract Year only up to an amount of **Rupees Two Crore and Ninety Lakhs only (Rs. 2.90 Crore)**.

### **14.4 Procedure for claiming indemnity**

- 14.4.1 Where the Indemnified Party is entitled to indemnification from the Indemnifying Party pursuant to Articles 14.1 or 14.2 the Indemnified Party shall promptly notify the Indemnifying Party of such claim, proceeding, action or suit referred to in Articles 14.1 or 14.2 in respect of which it is entitled to be indemnified. Such notice shall be given as soon as reasonably practicable after the Indemnified Party becomes aware of such claim, proceeding, action or suit. The Indemnifying Party shall be liable to settle the indemnification claim within thirty (30) days of receipt of the above notice.

Provided however that, if:

- i. the Parties choose to contest, defend or litigate such claim, action, suit or proceedings in accordance with Article 14.4.3 below; and
- ii. the claim amount is not required to be paid/deposited to such third party pending the resolution of the Dispute,

the Indemnifying Party shall become liable to pay the claim amount to the Indemnified Party or to the third party, as the case may be, promptly following the resolution of the Dispute, if such Dispute is not settled in favour of the Indemnified Party.

- 14.4.2 The Indemnified Party may contest, defend and litigate a claim, action, suit or proceeding for which it is entitled to be indemnified under Articles 14.1 or 14.2 and the Indemnifying Party shall reimburse to the Indemnified Party all reasonable costs and expenses incurred by the Indemnified Party. However, such Indemnified Party shall not settle or compromise such claim, action, suit or proceedings without first getting the consent of the Indemnifying Party, which consent shall not be unreasonably withheld or delayed.
- 14.4.3 An Indemnifying Party may, at its own expense, assume control of the defence of any proceedings brought against the Indemnified Party if it acknowledges its obligation to indemnify such Indemnified Party, gives such Indemnified Party prompt notice of its intention to assume control of the defence, and employs an independent legal counsel at its own cost that is reasonably satisfactory to the Indemnified Party.

#### **14.5 Limitation on Liability**

- 14.5.1 Except as expressly provided in this Agreement, neither the TSP nor the Nodal Agency nor their respective officers, directors, agents, employees or Affiliates (including, officers, directors, agents or employees of such Affiliates), shall be liable or responsible to the other Party or its Affiliates including its officers, directors, agents, employees, successors, insurers or permitted assigns for incidental, indirect or consequential, punitive or exemplary damages, connected with or resulting from performance or non-performance of this Agreement, or anything done in connection herewith, including claims in the nature of lost revenues, income or profits (other than payments expressly required and properly due under this Agreement), any increased expense of, reduction in or loss of transmission capacity or equipment used therefore, irrespective of whether such claims are based upon breach of warranty, tort (including negligence, whether of the Nodal Agency, the TSP or others), strict liability, contract, breach of statutory duty, operation of law or otherwise
- 14.5.2 The Nodal Agency shall have no recourse against any officer, director or shareholder of the TSP or any Affiliate of the TSP or any of its officers, directors or shareholders for such claims excluded under this Article. The TSP shall also have no recourse against any officer, director or

shareholder of the Nodal Agency, or any Affiliate of the Nodal Agency or any of its officers, directors or shareholders for such claims excluded under this Article.

**14.6 Duty to Mitigate**

The party entitled to the benefit of an indemnity under this Article 14 shall take all reasonable measures to mitigate any loss or damage which has occurred. If the Party fails to take such measures, the other Party's liabilities shall be correspondingly reduced.

**ARTICLE: 15**

**15 ASSIGNMENTS AND CHARGES**

**15.1 Assignments:**

15.1.1 This Agreement shall be binding upon, and inure to the benefit of the Parties and their respective successors and permitted assigns. This Agreement shall not be assigned by any Party, except as provided in Article 15.3.

**15.2 Permitted Charges:**

15.2.1 Neither Party shall create or permit to subsist any encumbrance over all or any of its rights and benefits under this Agreement.

15.2.2 However, the TSP may create any encumbrance over all or part of the receivables, or the Project Assets of the Project in favour of the Lenders or the Lenders' Representative on their behalf, as security for amounts payable under the Financing Agreements and any other amounts agreed by the Parties.

Provided that:

- i. the Lenders or the Lenders' Representative on their behalf shall have entered into the Financing Agreements and agreed in writing to the provisions of this Agreement; and
- ii. any encumbrance granted by the TSP in accordance with this Article 15.2.2 shall contain provisions pursuant to which the Lenders or the Lender's Representative on their behalf agrees unconditionally with the TSP to release from such encumbrances upon payment by the TSP to the Lenders of all amounts due under the Financing Agreements.

15.2.3 Article 15.2.1 does not apply to:

- a. liens arising by operation of law (or by an agreement evidencing the same) in the ordinary course of the TSP developing and operating the Project;
- b. pledges of goods, the related documents of title and / or other related documents, arising or created in the ordinary course of the TSP developing and operating the Project; or

- c. security arising out of retention of title provisions in relation to goods acquired in the ordinary course of the TSP developing and operating the Project.

**15.3 Substitution Rights of the Lenders**

- 15.3.1 The TSP would need to operate and maintain the Project under the provisions of this Agreement and cannot assign the Transmission License or transfer the Project or part thereof to any person by sale, lease, exchange or otherwise, without the prior approval of the Nodal Agency.
- 15.3.2 However, in the case of default by the TSP in debt repayments or in the case of default by the TSP as per Article 13 of this Agreement during the debt repayments, the Commission may, on an application from the Lenders, assign the Transmission License to the nominee of the Lenders subject to the fulfilment of the qualification requirements and provisions of the Central Electricity Regulatory Commission (Procedure, terms and Conditions for grant of Transmission License and other related matters) Regulations, 2006 and as amended from time to time.

## **ARTICLE: 16**

### **16 GOVERNING LAW AND DISPUTE RESOLUTION**

#### **16.1 Governing Law:**

This Agreement shall be governed by and construed in accordance with the Laws of India. Any legal proceedings in respect of any matters, claims or disputes under this Agreement shall be under the jurisdiction of appropriate courts in Delhi.

#### **16.2 Amicable Settlement:**

16.2.1 Either Party is entitled to raise any claim, dispute or difference of whatever nature arising under, out of or in connection with this Agreement, including its existence or validity or termination or whether during the execution of the Project or after its completion and whether prior to or after the abandonment of the Project or termination or breach of the Agreement by giving a written notice to the other Party, which shall contain:

- (i) a description of the Dispute;
- (ii) the grounds for such Dispute; and
- (iii) all written material in support of its claim.

16.2.2 The other Party shall, within thirty (30) days of issue of notice issued under Article 16.2.1, furnish:

- (i) counter-claim and defences, if any, regarding the Dispute; and
- (ii) all written material in support of its defences and counter-claim.

16.2.3 Within thirty (30) days of issue of notice by the Party pursuant to Article 16.2.1, if the other Party does not furnish any counter claim or defense under Article 16.2.2, or thirty (30) days from the date of furnishing counter claims or defence by the other Party, both the Parties to the Dispute shall meet to settle such Dispute amicably. If the Parties fail to resolve the Dispute amicably within thirty (30) days from the later of the dates mentioned in this Article 16.2.3, the Dispute shall be referred for dispute resolution in accordance with Article 16.3.

#### **16.3 Dispute Resolution:**

All Disputes shall be adjudicated by the Commission.

**16.4 Parties to Perform Obligations:**

Notwithstanding the existence of any Dispute and difference referred to the Commission as provided in Article 16.3 and save as the Commission may otherwise direct by a final or interim order, the Parties hereto shall continue to perform their respective obligations/ roles (which are not in dispute) under this Agreement.

**ARTICLE: 17**

**17 REPRESENTATION AND WARRANTIES**

**17.1 Representation and warranties of the Nodal Agency**

17.1.1 The Nodal Agency hereby represents and warrants to and agrees with the TSP as follows and acknowledges and confirms that the TSP is relying on such representations and warranties in connection with the transactions described in this Agreement:

- a. It has all requisite powers and authority to execute and consummate this Agreement;
- b. This Agreement is enforceable against the Nodal Agency in accordance with its terms;
- c. The consummation of the transactions contemplated by this Agreement on the part of Nodal Agency will not violate any provision of nor constitute a default under, nor give rise to a power to cancel any charter, mortgage, deed of trust or lien, lease, agreement, license, permit, evidence of indebtedness, restriction, or other contract to which the Nodal Agency is a Party or to which the Nodal Agency is bound, which violation, default or power has not been waived;

**17.2 Representation and Warranties of the TSP:**

17.2.1 The TSP hereby represents and warrants to and agrees with the Nodal Agency as follows and acknowledges and confirms that the Nodal Agency is relying on such representations and warranties in connection with the transactions described in this Agreement:

- a. It has all requisite powers and has been duly authorized to execute and consummate this Agreement;
- b. This Agreement is enforceable against it, in accordance with its terms;
- c. The consummation of the transactions contemplated by this Agreement on the part of the TSP will not violate any provision of nor constitute a default under, nor give rise to a power to cancel any charter, mortgage, deed of trust or lien, lease, agreement, license, permit, evidence of indebtedness, restriction, or other contract to which the TSP is a Party or to which the TSP is bound which violation, default or power has not been waived;

- d. The TSP is not insolvent and no insolvency proceedings have been instituted, nor threatened or pending by or against the TSP;
  - e. There are no actions, suits, claims, proceedings or investigations pending or, to the best of the TSP's knowledge, threatened in writing against the TSP at law, in equity, or otherwise, and whether civil or criminal in nature, before or by, any court, commission, arbitrator or governmental agency or authority, and there are no outstanding judgments, decrees or orders of any such courts, commission, arbitrator or governmental agencies or authorities, which materially adversely affect its ability to execute the project or to comply with its obligations under this Agreement.
- 17.2.2 The TSP makes all the representations and warranties above to be valid as on the Effective Date of this Agreement.

## **ARTICLE: 18**

### **18 INDEPENDENT ENGINEER**

#### **18.1 Appointment of Independent Engineer**

The Nodal Agency shall appoint an agency/ company as Independent Engineer as per framework provided in the Guidelines for Encouraging Competition in Development of Transmission Projects for selection of Independent Engineer.

#### **18.2 Roles and functions of Independent Engineer**

The role and functions of the Independent Engineer shall include the following:

- a. Progress Monitoring as required under this Agreement;
- b. Ensuring Quality as required under this Agreement;
- c. determining, as required under the Agreement, the costs of any works or services and/or their reasonableness during construction phase;
- d. determining, as required under the Agreement, the period or any extension thereof, for performing any duty or obligation during construction phase;
- e. determining, as required under the Agreement, the valuation of the Project Assets.
- f. Assisting the Parties in resolution of Disputes and
- g. Undertaking all other duties and functions in accordance with the Agreement.

#### **18.3 Remuneration of Independent Engineer**

The fee and charges of the Independent Engineer shall be paid by the Nodal Agency as per terms & conditions of appointment.

#### **18.4 Termination of appointment**

18.4.1 The Nodal Agency may, in its discretion, terminate the appointment of the Independent Engineer at any time, but only after appointment of another Independent Engineer.

18.4.2 If the TSP has reason to believe that the Independent Engineer is not discharging its duties and functions in a fair, efficient and diligent manner, it

may make a written representation to the Nodal Agency and seek termination of the appointment of the Independent Engineer. Upon receipt of such representation, the Nodal Agency shall hold a tripartite meeting with the TSP and Independent Engineer for an amicable resolution, and the decision of Nodal agency is final. In the event that the appointment of the Independent Engineer is terminated hereunder, the Nodal Agency shall appoint forthwith another Independent Engineer.

#### **18.5 Authorised signatories**

The Nodal Agency shall require the Independent Engineer to designate and notify to the Nodal Agency up to 2 (two) persons employed in its firm to sign for and on behalf of the Independent Engineer, and any communication or document required to be signed by the Independent Engineer shall be valid and effective only if signed by any of the designated persons; provided that the Independent Engineer may, by notice in writing, substitute any of the designated persons by any of its employees.

**ARTICLE: 19**

**19 MISCELLANEOUS PROVISIONS**

**19.1 Equity Lock-in Commitment:**

19.1.1 The aggregate equity share holding of the Selected Bidder in the issued and paid up equity share capital of .....(Insert Name of the SPV) shall not be less than Fifty one percent (51%) up to a period of one (1) year after COD of the Project.

Provided that, in case the Lead Member or Bidding Company is holding equity through Affiliate/s, Ultimate Parent Company or Parent Company, such restriction as specified above shall apply to such entities.

Provided further, that in case the Selected Bidder is a Bidding Consortium, the Lead Member shall continue to hold equity of at least twenty six percent (26%) upto a period of one (1) year after COD of the Project and any Member of such Bidding Consortium shall be allowed to divest its equity as long as the other remaining Members (which shall always include the Lead Member) hold the minimum equity specified above.

19.1.2 If equity is held by the Affiliates, Parent Company or Ultimate Parent Company of the Selected Bidder, then, subject to the second proviso to Article 19.1.1, such Affiliate, Parent Company or Ultimate Parent Company shall be eligible to transfer its shareholding in ..... (Insert Name of the SPV) to another Affiliate or to the Parent Company / Ultimate Parent Company of the Selected Bidder. If any such shareholding entity, qualifying as an Affiliate / Parent Company / Ultimate Parent Company, is likely to cease to meet the criteria to qualify as an Affiliate / Parent Company / Ultimate Parent Company, the shares held by such entity shall be transferred to another Affiliate / Parent Company / Ultimate Parent Company of the Selected Bidder.

19.1.3 Subject to Article 19.1.1, all transfer(s) of shareholding of .....(Insert Name of the SPV) by any of the entities referred to in Article 19.1.1 and 19.1.2 above, shall be after prior written intimation to the Nodal Agency.

19.1.4 For computation of effective Equity holding, the Equity holding of the Selected Bidder or its Ultimate Parent Company in such Affiliate(s) or Parent Company and the equity holding of such Affiliate(s) or Ultimate Parent Company in .....(Insert Name of the SPV) shall be computed in accordance with the example given below:

If the Parent Company or the Ultimate Parent Company of the Selected Bidder A directly holds thirty percent (30%) of the equity in .....(Insert Name of the SPV) then holding of Selected Bidder A in .....(Insert Name of the SPV) shall be thirty percent (30%);

If Selected Bidder A holds thirty percent (30%) equity of the Affiliate and the Affiliate holds fifty percent (50%) equity in .....(Insert Name of the SPV), then, for the purposes of ascertaining the minimum equity/equity lock-in requirements specified above, the effective holding of Bidder A in .....(Insert Name of the SPV) shall be fifteen percent (15%), (i.e., 30% x 50%)

19.1.5 The provisions as contained in this Article 19.1 shall override the terms of the consortium agreement submitted as part of the Bid.

19.1.6 The TSP shall be responsible to report to Nodal Agency, within thirty (30) days from the occurrence of any event that would result in any change in its equity holding structure from that which existed as on the date of signing of the Share Purchase Agreement. In such cases, the Nodal Agency would reserve the right to ascertain the equity holding structure and to call for all such required documents / information / clarifications as may be required.

**19.2 Commitment of maintaining Qualification Requirement**

19.2.1 The Selected Bidder will be required to continue to maintain compliance with the Qualification Requirements, as stipulated in RFP Document, till the COD of the Project. Where the Technically Evaluated Entity and/or the Financially Evaluated Entity is not the Bidding Company or a Member in a Bidding Consortium, as the case may be, the Bidding Company or Member shall continue to be an Affiliate of the Technically Evaluated Entity and/or Financially Evaluated Entity till the COD of the Project.

19.2.2 Failure to comply with the aforesaid provisions shall be dealt in the same manner as TSP's Event of Default as under Article 13 of this Agreement.

**19.3 Language:**

19.3.1 All agreements, correspondence and communications between the Parties relating to this Agreement and all other documentation to be prepared and supplied under the Agreement shall be written in English, and the Agreement shall be construed and interpreted in accordance with English language.

19.3.2 If any of the agreements, correspondence, communications or documents are prepared in any language other than English, the English

translation of such agreements, correspondence, communications or documents shall prevail in matters of interpretation.

**19.4 Affirmation**

The TSP and the Nodal Agency, each affirm that:

1. neither it nor its respective directors, employees, or agents has paid or undertaken to pay or shall in the future pay any unlawful commission, bribe, pay-off or kick-back; and
2. it has not in any other manner paid any sums, whether in Indian currency or foreign currency and whether in India or abroad to the other Party to procure this Agreement, and the TSP and the Nodal Agency hereby undertake not to engage in any similar acts during the Term of Agreement.

**19.5 Severability**

The invalidity or enforceability, for any reason, of any part of this Agreement shall not prejudice or affect the validity or enforceability of the remainder of this Agreement, unless the part held invalid or unenforceable is fundamental to this Agreement.

**19.6 Counterparts**

This Agreement may be executed in one or more counterparts, each of which shall be deemed an original and all of which collectively shall be deemed one and the same Agreement.

**19.7 Breach of Obligations/ Roles**

The Parties acknowledge that a breach of any of the obligations/ roles contained herein would result in injuries. The Parties further acknowledge that the amount of the liquidated damages or the method of calculating the liquidated damages specified in this Agreement is a genuine and reasonable pre-estimate of the damages that may be suffered by the non-defaulting Party in each case specified under this Agreement.

**19.8 Restriction of Shareholders / Owners Liability**

- 19.8.1 Parties expressly agree and acknowledge that none of the shareholders of the Parties hereto shall be liable to the other Parties for any of the contractual obligations of the concerned Party under this Agreement.

- 19.8.2 Further, the financial liabilities of the shareholder(s) of each Party to this Agreement shall be restricted to the extent provided in the Indian Companies Act, 1956 / Companies Act, 2013 (as the case may be).

**19.9 Taxes and Duties:**

- 19.9.1 The TSP shall bear and promptly pay all statutory taxes, duties, levies and cess, assessed/levied on the TSP, its Contractors or their employees that are required to be paid by the TSP as per the Law in relation to the execution of the Project and for providing Transmission Service as per the terms of this Agreement.
- 19.9.2 The Nodal Agency shall be indemnified and held harmless by the TSP against any claims that may be made against the Nodal Agency in relation to the matters set out in Article 19.9.1.
- 19.9.3 The Nodal Agency shall not be liable for any payment of, taxes, duties, levies, cess whatsoever for discharging any obligation of the TSP by the Nodal Agency on behalf of TSP or its personnel, provided the TSP has consented in writing to the Nodal Agency for such work, for which consent shall not be unreasonably withheld.

**19.10 No Consequential or Indirect Losses**

The liability of the TSP shall be limited to that explicitly provided in this Agreement.

Provided that, notwithstanding anything contained in this Agreement, under no event shall the Nodal Agency or the TSP claim from one another any indirect or consequential losses or damages.

**19.11 Discretion:**

Except where this Agreement expressly requires a Party to act fairly or reasonably, a Party may exercise any discretion given to it under this Agreement in any way it deems fit.

**19.12 Confidentiality**

- 19.12.1 The Parties undertake to hold in confidence this Agreement and RFP Project Documents and not to disclose the terms and conditions of the transaction contemplated hereby to third parties, except:
- (a) to their professional advisors;
  - (b) to their officers, contractors, employees, agents or representatives, financiers, who need to have access to such

information for the proper performance of their activities; or

(c) disclosures required under Law,

without the prior written consent of the other Parties.

Provided that, the TSP agrees and acknowledges that the Nodal Agency, may, at any time, disclose the terms and conditions of the Agreement and the RFP Project Documents to any person, to the extent stipulated under the Law and the Competitive Bidding Guidelines.

**19.13 Order of priority in application:**

Save as provided in Article 2.5, in case of inconsistencies between the terms and conditions stipulated in Transmission License issued by the Commission to the TSP, agreement(s) executed between the Parties, applicable Law including rules and regulations framed thereunder, the order of priority as between them shall be the order in which they are placed below:

- terms and conditions of Transmission License;
- applicable Law, rules and regulations framed thereunder;
- this Agreement;
- Agreement(s), if any, under Sharing Regulations.

**19.14 Independent Entity:**

19.14.1 The TSP shall be an independent entity performing its obligations pursuant to the Agreement.

19.14.2 Subject to the provisions of the Agreement, the TSP shall be solely responsible for the manner in which its obligations under this Agreement are to be performed. All employees and representatives of the TSP or Contractors engaged by the TSP in connection with the performance of the Agreement shall be under the complete control of the TSP and shall not be deemed to be employees, representatives, Contractors of the Nodal Agency and nothing contained in the Agreement or in any agreement or contract awarded by the TSP shall be construed to create any contractual relationship between any such employees, representatives or Contractors and the Nodal Agency.

**19.15 Amendments:**

19.15.1 This Agreement may only be amended or supplemented by a written

agreement between the Parties.

**19.16 Waiver:**

- 19.16.1 No waiver by either Party of any default or breach by the other Party in the performance of any of the provisions of this Agreement shall be effective unless in writing duly executed by an authorised representative of such Party.
- 19.16.2 Neither the failure by either Party to insist on any occasion upon the performance of the terms, conditions and provisions of this Agreement nor time or other indulgence granted by one Party to the other Parties shall act as a waiver of such breach or acceptance of any variation or the relinquishment of any such right or any other right under this Agreement, which shall remain in full force and effect.

**19.17 Relationship of the Parties:**

This Agreement shall not be interpreted or construed to create an association, joint venture, or partnership or agency or any such other relationship between the Parties or to impose any partnership obligation or liability upon either Party and neither Party shall have any right, power or authority to enter into any agreement or undertaking for, or act on behalf of, or to act as or be an agent or representative of, or to otherwise bind, the other Party.

**19.18 Entirety:**

- 19.18.1 This Agreement along with its sections, schedules and appendices is intended by the Parties as the final expression of their agreement and is intended also as a complete and exclusive statement of the terms of their agreement.
- 19.18.2 Except as provided in this Agreement, all prior written or oral understandings, offers or other communications of every kind pertaining to this Agreement or the provision of Transmission Service under this Agreement to the Nodal Agency by the TSP shall stand superseded and abrogated.

**19.19 Notices:**

- 19.19.1 All notices or other communications which are required to be given under this Agreement shall be in writing and in the English language
- 19.19.2 If to the TSP, all notices or communications must be delivered personally or by registered post or facsimile or any other mode duly acknowledged

to the addressee below:

Address :  
Attention :  
Email :  
Fax. No. :  
Telephone No. :

19.19.3 If to the Nodal Agency, all notices or communications must be delivered personally or by registered post or facsimile or any other mode duly acknowledged to the addresses below:

(i).....[Insert Name of the Nodal Agency]

Address :  
Attention :  
Email :  
Fax. No. :  
Telephone No. :

19.19.4 All notices or communications given by facsimile shall be confirmed by sending a copy of the same via post office in an envelope properly addressed to the appropriate Party for delivery by registered mail. All notices shall be deemed validly delivered upon receipt evidenced by an acknowledgement of the recipient, unless the Party delivering the notice can prove in case of delivery through the registered post that the recipient refused to acknowledge the receipt of the notice despite efforts of the postal authorities.

19.19.5 Any Party may by notice of at least fifteen (15) days to the other Party change the address and/or addresses to which such notices and communications to it are to be delivered or mailed.

**19.20 Fraudulent and Corrupt Practices**

19.20.1 The TSP and its respective officers, employees, agents and advisers shall observe the highest standard of ethics during the subsistence of this Agreement. Notwithstanding anything to the contrary contained in the Agreement, the Nodal Agency may terminate the Agreement without being liable in any manner whatsoever to the TSP, if it determines that the TSP has, directly or indirectly or through an agent, engaged in corrupt practice, fraudulent practice, coercive practice, undesirable practice or restrictive practice in the Bid process. In such an event, the

Nodal Agency shall forfeit the Contract Performance Guarantee of the TSP, without prejudice to any other right or remedy that may be available to the Nodal Agency hereunder or subsistence otherwise.

19.20.2 Without prejudice to the rights of the Nodal Agency under Clause 19.20.1 hereinabove and the rights and remedies which the Nodal Agency may have under this Agreement, if a TSP is found by the Nodal Agency to have directly or indirectly or through an agent, engaged or indulged in any corrupt practice, fraudulent practice, coercive practice, undesirable practice or restrictive practice during the Bid process, or after the issue of Letter of Intent (hereinafter referred to as Lol) or after the execution of the agreement(s) required under Sharing Regulations, the Nodal Agency may terminate the Agreement without being liable in any manner whatsoever to the TSP. Further, the TSP & its Affiliates shall not be eligible to participate in any tender or RFP issued by any BPC for an indefinite period from the date such TSP is found by the Nodal Agency to have directly or indirectly or through an agent, engaged or indulged in any corrupt practice, fraudulent practice, coercive practice, undesirable practice or restrictive practices, as the case may be.

19.20.3 For the purposes of this Clause 19.20, the following terms shall have the meaning hereinafter respectively assigned to them:

(a) **“corrupt practice”** means (i) the offering, giving, receiving, or soliciting, directly or indirectly, of anything of value to influence the actions of any person connected with the Bid process (for avoidance of doubt, offering of employment to or employing or engaging in any manner whatsoever, directly or indirectly, any official of the BPC who is or has been associated or dealt in any manner, directly or indirectly with the Bid process or the Lol or has dealt with matters concerning the RFP Project Documents or arising there from, before or after the execution thereof, at any time prior to the expiry of one year from the date such official resigns or retires from or otherwise ceases to be in the service of the BPC, shall be deemed to constitute influencing the actions of a person connected with the Bid Process); or (ii) engaging in any manner whatsoever, whether during the Bid Process or after the issue of the Lol or after the execution of the RFP Project Documents, as the case may be, any person in respect of any matter relating to the Project or the Lol or the RFP Project Documents, who at any time has been or is a legal, financial or technical adviser of the BPC in relation to any matter concerning the Project;

(b) **“fraudulent practice”** means a misrepresentation or omission of facts or suppression of facts or disclosure of incomplete facts, in order to influence the Bid process;

(c) “**coercive practice**” means impairing or harming, or threatening to impair or harm, directly or indirectly, any person or property to influence any person’s participation or action in the Bid process;

(d) “**undesirable practice**” means (i) establishing contact with any person connected with or employed or engaged by the BPC with the objective of canvassing, lobbying or in any manner influencing or attempting to influence the Bid process; or (ii) having a Conflict of Interest; and

(e) “**restrictive practice**” means forming a cartel or arriving at any understanding or arrangement among Bidders with the objective of restricting or manipulating a full and fair competition in the Bid process;

**19.21 Compliance with Law:**

Despite anything contained in this Agreement but without prejudice to Article 12, if any provision of this Agreement shall be in deviation or inconsistent with or repugnant to the provisions contained in the Electricity Act, 2003, or any rules and regulations made there under, such provision shall be deemed to be amended to the extent required to bring it into compliance with the aforesaid relevant provisions as amended from time to time.

**IN WITNESS WHEREOF, THE PARTIES HAVE CAUSED THIS AGREEMENT TO BE EXECUTED BY THEIR DULY AUTHORISED REPRESENTATIVES AS OF THE DATE AND PLACE SET FORTH ABOVE.**

1. For and on behalf of TSP

.....

[Signature, Name, Designation and Address]

2. For and on behalf of..... [Insert name of the Nodal Agency]

.....

[Signature, Name, Designation and Address]

**WITNESSES:**

1. For and on behalf of  
: BPC

.....  
[Signature]

.....  
[Insert, Name, Designation and Address of the Witness]

2. For and on behalf of  
: Nodal Agency

.....  
[Signature]

.....  
[Insert Name, Designation and Address of the Witness]

# SCHEDULES

**Schedule: 1****Project Description and Scope of Project****Scope of the Project:**

Sl. No.	Scope of the Transmission Scheme	Scheduled COD in months from Effective Date
1.	Augmentation of 400/220 kV, 5x500 MVA (6 <sup>th</sup> to 10 <sup>th</sup> ) ICTs at 765/400/220 kV Bhadla-III PS <ul style="list-style-type: none"> <li>• 500 MVA, 400/220 kV ICT - 5 Nos. (4 Nos. ICTs in 220 kV Sec-2 (6<sup>th</sup> to 9<sup>th</sup>) and 1 No. ICT in 220 kV Sec-1 (10<sup>th</sup>))</li> <li>• 400 kV ICT bay – 5 Nos.</li> <li>• 220 kV ICT bay – 4 Nos.</li> <li>• 220 kV ICT (GIS) bay – 1 No. (for 10<sup>th</sup> ICT)</li> <li>• 220 kV GIS bus duct/Cable for interconnection of 220 kV side of ICT (10<sup>th</sup>) to 220 kV GIS bay (Section-1)</li> </ul>	20.01.2029 (matching with timeframe of Transmission System for Evacuation of Power from REZ in Rajasthan (20 GW) under Phase III – Part I scheme (Pole 1))
2.	Implementation of 5 Nos. of 220 kV line bays at 765/400/220 kV Bhadla-III PS. <ul style="list-style-type: none"> <li>• 220 kV line bay – 5 Nos.</li> </ul>	
3.	Implementation of 1 No. of 400 kV line bay at 765/400/220 kV Bhadla-III PS. <ul style="list-style-type: none"> <li>• 400 kV line bay – 1 No.</li> </ul>	
4.	Implementation of 2 sets 400 kV sectionlizer bay at 765/400/220 kV Bhadla-III PS <ul style="list-style-type: none"> <li>• 400 kV sectionalizer bay – 2 sets</li> </ul>	
5.	Augmentation of 765/400 kV, 2x1500 MVA (3 <sup>rd</sup> & 4 <sup>th</sup> ) ICTs at 765/400/220 kV Ramgarh PS <ul style="list-style-type: none"> <li>• 1500 MVA, 765/400 kV ICT - 2 Nos.</li> <li>• 765 kV ICT bay – 2 Nos.</li> <li>• 400 kV ICT bay – 2 Nos.</li> </ul>	
6.	Augmentation of 400/220 kV, 2x500 MVA (3 <sup>rd</sup> & 4 <sup>th</sup> ) ICTs at 765/400/220 kV Ramgarh PS <ul style="list-style-type: none"> <li>• 500 MVA, 400/220 kV ICT - 2 Nos.</li> <li>• 400 kV ICT bays – 2 Nos.</li> <li>• 220 kV ICT bay – 2 Nos.</li> </ul>	

7.	Implementation of 2 Nos. of 220 kV line bays at 765/400/220 kV Ramgarh PS <ul style="list-style-type: none"> <li>• 220 kV line bay – 2 Nos.</li> </ul>	
8.	Implementation of 1 No. of 400 kV line bay at 765/400/220 kV Ramgarh PS <ul style="list-style-type: none"> <li>• 400 kV line bay – 1 No.</li> </ul>	
9.	Augmentation of 765/400 kV, 1x1500 MVA (3 <sup>rd</sup> ) ICT at 765/400 kV Kanpur (PG) substation <ul style="list-style-type: none"> <li>• 1500 MVA (3x500 MVA), 765/400 kV ICT - 1 No.</li> <li>• 765 kV ICT bay (GIS) including completion of diameter.</li> <li>• 400 kV ICT bay (GIS) in existing spare bay</li> <li>• All associated GIS duct with terminations.</li> </ul>	

### Project Description

Transmission System requirement for additional 20 GW REZ in Northern Region (Phase-III) was approved in 5<sup>th</sup> NCT meeting held on 25.08.21 & 02.09.21. As part of above scheme, establishment of 765/400/220 kV Bhadla- III PS, 765/400/220 kV Ramgarh PS along with associated EHVAC system was approved in Phase-III Part B1 package & Part C1 package of scheme respectively

Further in 5<sup>th</sup> NCT meeting, it was decided that augmentation of 1x1500 MVA ICT at 765/400 kV Kanpur (GIS) substation as part of Phase-III, Part J scheme is linked with HVDC system (LILO of Varanasi-Kanpur at Fatehpur) and since the timeframe of HVDC has now been delayed, therefore, this item could also be taken up later.

Subsequently, Augmentation of 400/220 kV 2x500 MVA (4<sup>th</sup> & 5<sup>th</sup>) ICTs, Augmentation of 765/400 kV 2x1500 MVA (3<sup>rd</sup> & 4<sup>th</sup>) ICTs along with 220 kV BC & TBC bay at Bhadla-III PS was approved as part of Transmission system of “Additional Transmission system for evacuation of power from Bhadla-III PS as part of Rajasthan REZ Phase-III scheme (20 GW)”. The scheme is also under implementation.

As Connectivity application has already been granted at Ramgarh and Bhadla-III PS. with fulfilment of connectivity grant process, additional no. of ICTs along with line bays (400 kV and 220 kV) are required for RE interconnection in matching timeframe of Transmission System for Evacuation of Power from REZ in Rajasthan (20 GW) under Phase III scheme (Bhadla-Fatehpur HVDC scheme (Pole 1).

The scheme comprises augmentation of 400/220 kV, 5x500 MVA (6<sup>th</sup>-10<sup>th</sup>) ICTs, Implementation of 5 Nos. of 220 kV line bays & 1 No. of 400 kV line bay at 765/400/220 kV Bhadla-III PS as well as augmentation with 765/400 kV, 2x1500 MVA (3<sup>rd</sup> & 4<sup>th</sup>) ICTs, 400/220 kV, 2x500 MVA (3<sup>rd</sup> & 4<sup>th</sup>) ICTs, Implementation of 2 Nos. of 220 kV line bays & 1 No. of 400 kV line bay at 765/400/220 kV Ramgarh PS. The scope also covers augmentation with 765/400 kV, 1x1500 MVA (3<sup>rd</sup>) ICT at 765/400 kV Kanpur (PG) substation.

Augmentation at Kanpur (GIS) S/s as part of Transmission system for evacuation of power from REZ in Rajasthan (20 GW) under Phase III was agreed in the 3<sup>rd</sup> NRPC-TP meeting held on 19.02.21, 49<sup>th</sup> NRPC meeting held on 27.09.21 & 5<sup>th</sup> National Committee on Transmission (NCT) held on 25.08.21 and 02.09.21. Further, augmentation at Bhadla-III PS & Ramgarh PS is agreed in 41<sup>st</sup> CMETS-NR meeting held on 10.10.25. The composite scheme was approved in 37<sup>th</sup> NCT held on 19.01.2026. Subsequently, Ministry of Power, Government of India, vide its Gazette Notification no. CG-DL-E-19022026-270309 dated 12.02.2026 declared establishment of “Augmentation at Bhadla-III, Ramgarh PS and Kanpur (PG)” through tariff based competitive bidding process route.

### **SPECIFIC TECHNICAL REQUIREMENTS FOR SUBSTATION**

Extension of 765/400/220 kV Bhadla-III PS shall be conventional Air Insulated Substation (AIS) type (Bay of 10<sup>th</sup> ICT on 220 kV side shall be GIS) generally conforming to the requirements of CEA (Technical Standards for Construction of Electrical Plants and Electric Lines) Regulations 2022, as amended from time to time.

Extension of 765/400/220 kV Ramgarh PS shall be conventional Air Insulated Substation (AIS) type generally conforming to the requirements of CEA (Technical Standards for Construction of Electrical Plants and Electric Lines) Regulations 2022, as amended from time to time.

Extension of 765/400 kV Kanpur (PG) S/s shall be Gas Insulated Substation (GIS) type generally conforming to the requirements of CEA (Technical Standards for Construction of Electrical Plants and Electric Lines) Regulations 2022, as amended from time to time.

Other CEA Regulations/guidelines as amended up to date and MoP guidelines, as applicable, shall also be followed.

#### **B.1.0 Salient features of Substation Equipment and Facilities**

The design and specification of substation equipment are to be governed by the following factors:

#### **B.1.1 Insulation Coordination**

The system design parameters for substations/switchyards shall be as given below:

Sl. No	Description of parameters	Extn. of 765/400/220 kV Ramgarh PS		
		765 kV System	400 kV System	220 kV System
1.	System Operating Voltage	765 kV	400 kV	220 kV
2.	Maximum voltage of the system (rms)	800 kV	420 kV	245 kV
3.	Rated Frequency	50 Hz	50 Hz	50 Hz
4.	No. of Phases	3	3	3
5.	Rated Insulation Levels			
i)	Lightening Impulse withstand voltage for (1.2/50 micro sec.)			
	- for Equipment other than Transformer and Reactor	2100 kVp	1425 kVp	1050 kVp
	- for Insulator String	2100 kVp	1550 kVp	1050 kVp

SI. No	Description of parameters	Extn. of 765/400/220 kV Ramgarh PS		
		765 kV System	400 kV System	220 kV System
ii)	Switching Impulse withstand voltage (250/2500 micro sec.) dry and wet	1550 kVp	1050 kVp	-
iii)	One minute power frequency dry withstand voltage (rms)	830 kV	630 kV	-
iv)	One minute power frequency dry and wet withstand voltage (rms)		-	460 kV
6.	Corona Extinction Voltage	508 kV	320 kV	-
7.	Max. radio interference voltage for frequency between 0.5 MHz and 2 MHz	2500 micro-volts at 508 kV rms	1000 micro-volts at 266 kVrms	1000 micro-volts at 156 kVrms
8.	Minimum creepage distance for insulator string/ longrod insulators/ outdoor bushings	24800 mm (31mm/kV)	13020 mm (31 mm/kV)	7595 mm (31 mm/kV)
9.	Minimum creepage distance for switchyard equipment	20000 mm (25 mm/kV)	10500 mm (25 mm/kV)	6125 mm (25 mm/kV)
10.	Max. fault current	50 kA	63 kA	50 kA
11.	Duration of Fault	1 sec	1 sec	1 sec

SI. No	Description of parameters	Extn. of 765/400/220 kV Bhadla-III PS		Extn. of 765/400 kV Kanpur (PG) S/s	
		400 kV System	220 kV System	765 kV System	400 kV System
1.	System Operating Voltage	400 kV	220 kV	765 kV	400 kV
2.	Maximum voltage of the system (rms)	420 kV	245 kV	800 kV	420 kV
3.	Rated Frequency	50 Hz	50 Hz	50 Hz	50 Hz
4.	No. of Phases	3	3	3	3
5.	Rated Insulation Levels				
i)	Lightening Impulse withstand voltage for (1.2/50 micro sec.) - for Equipment other than Transformer and Reactor - for Insulator String	1425 kVp 1550 kVp	1050 kVp 1050 kVp	2100 kVp 2100 kVp	1425kVp 1550 kVp
ii)	Switching Impulse withstand voltage (250/2500 micro sec.) dry and wet	1050 kVp	-	1550 kVp/ 1425 kVp for GIS	1050 kVp

Sl. No	Description of parameters	Extn. of 765/400/220 kV Bhadla-III PS		Extn. of 765/400 kV Kanpur (PG) S/s	
		400 kV System	220 kV System	765 kV System	400 kV System
iii)	One minute power frequency dry withstand voltage (rms)	630 kV	-	830 kV (AIS)/ 960 kV (GIS)	630 kV (AIS)/ 650 kV (GIS)
iv)	One minute power frequency dry and wet withstand voltage (rms)	-	460 kV		-
6.	Corona Extinction Voltage	320 kV	-	508 kV	320 kV
7.	Max. radio interference voltage for frequency between 0.5 MHz and 2 MHz	1000 micro- volts at 266kV rms	1000 micro- volts at 156 kV rms	2500 micro- volts at 508 kV rms	1000 micro- volts at 266 kV rms
8.	Minimum creepage distance for insulator string/ longrod insulators/ outdoor bushings	13020 mm (31 mm/kV)	7595 mm (31 mm/kV)	24800 mm (31 mm/kV)	13020 mm (31 mm/kV)
9.	Minimum creepage distance for switchyard equipment	10500 mm (25 mm/kV)	6125 mm (25 mm/kV)	20000 mm (25 mm/kV)	10500 mm (25 mm/kV)
10.	Max. Fault Current	63 kA	50 kA	50 kA	63 kA
11.	Duration of Fault	1 sec	1 Sec	1 sec	1 sec

### B.1.2 Switching Scheme

The switching schemes, as mentioned below, shall be adopted at various voltage levels of substation/switchyard:

Substation	765 kV side	400 kV side	220 kV side
Extn. of 765/400/220 kV Bhadla-III PS	One and Half breaker	One and Half breaker	Double Main and Transfer (AIS)/ Double Main (GIS extn.)
Extn. of 765/400/220 kV Ramgarh PS	One and Half breaker	One and Half breaker	Double Main and Transfer
Extn. of 765/400 kV Kanpur (PG) S/s	One and Half breaker	One and Half breaker	-NA-

Notes: -

- i) *Two transformers of same HV rating shall not be connected in the same diameter and similarly two bus reactors of same HV rating shall also not be connected in the same diameter.*
- ii) *A diameter in one and half breaker scheme is a set of 3 circuit breakers with associated isolators, earth switches, current transformers etc. for controlling 2(two) numbers of feeders.*
- iii) *In case of GIS substation where the bus scheme is One & Half breaker scheme, the diameters shall be complete with feeder/line side isolator to be used for any future line bay and GIS duct of the future bay shall be brought outside the GIS hall/building with extension/interface module suitably.*
- iv) *TSP shall plan distribution of line and transformer feeders to bus bar in such a way that all power can be evacuated successfully without crossing thermal limit at any point of bus bar.*
- v) **Extension of Bhadla-III PS:**

*(a) 5 Nos. of 220 kV line bays (Bay No. – 218, 220, 226, 227 & 231) shall be constructed under present scope at Bhadla-III PS at 220 kV level.*

*(b) 1 No. of 400 kV line bay shall be terminated in the new diameter at Bhadla-III PS. Accordingly, one no. Main Bay and associated Tie Bay (430- Main Bay & 431- Tie Bay) shall be constructed under present scope at Bhadla-III PS.*

*(c) TSP shall also construct 02 sets of bus sectionalizer at 400 kV level (set-1: Bay No. 419 & 420, set-2: Bay No. 442 & 443)*

**400/220 kV for ICT Termination:**

*(d) Four Nos. (out of 5 Nos.) 500 MVA ICTs shall be terminated at the 220 kV bus Section-2 in AIS arrangement. In addition, one number of 500 MVA ICTs shall be connected at the 220 kV bus Section-1 through GIS/cable arrangement alongwith associated indoor/outdoor GIS bay under the present scope of work.*

*(e) Single Line Diagram (Drg. No. C/ENGG/SS/BHADLA-3/SLD, Rev. No.-00) of Bhadla-III substation attached with the RfP shall be referred in this regard.*

*(f) Further, all associated interconnection work shall also be in the present scope of TSP.*

vi) **Extension of Ramgarh PS:**

*(a) For Augmentation of 765/400 kV, 2x1500 MVA (3rd & 4th) ICTs, both ICT shall be installed in two number new diameters at Ramgarh PS. Accordingly, 2 Nos. Main Bay and associated Tie Bay (712- Main Bay & 711- Tie Bay and 715- Main Bay & 714- Tie*

- Bay) shall be constructed under present scope at Ramgarh PS at 765 kV level and 02 Nos. Main Bay and associated Tie Bay (421- Main Bay & 422- Tie Bay and 424- Main Bay & 425- Tie Bay) shall be constructed under present scope at Ramgarh PS at 400 kV level.*
- (b) *For Augmentation of 400/220 kV, 2x500 MVA (3rd & 4th) ICTs, 2 numbers Main Bays (Main Bay 423 & Main Bay 426) shall be constructed under present scope at Ramgarh PS at 400 kV level.*
- (c) *2 numbers of 220 kV line bays (Bay No. – 207 & 208) shall be constructed under present scope at Ramgarh PS.*
- (d) *1 number of 400 kV line bay (Main Bay No. – 406) shall be constructed in the existing diameter at Ramgarh PS.*
- (e) *Single Line Diagram (Drg. No. C/ENGG/SS/RAMGARH PS/SLD ) of Ramgarh PS substation attached with the RfP shall be referred in this regard.*
- (f) *Further, all associated interconnection work shall also be in the present scope of TSP.*
- vii) **Extension of Kanpur (PG) S/s:**
- (a) *For Augmentation of 765/400 kV, 1x1500 MVA (3rd) ICT shall be terminated in new diameter at 765 kV voltage level and in the existing bay at 400 kV voltage level. Accordingly, 2 numbers main bays (1 for ICT termination & 1 for diameter completion) and associated Tie bay shall be constructed at 765 kV level under present scope at Kanpur (PG) S/s.*
- (b) *Single Line Diagram (Drg. No.- PG/PGCIL/KNP/SLd-drg/001,Rev. No.-R4) of Kanpur substation attached with the RfP shall be referred in this regard.*
- (c) *Further, all associated interconnection work including surge arrester for 400kV side of ICT shall also be in the present scope of TSP.*

**B.2.0 Substation Equipment and facilities (Voltage level as applicable):**

The switchgear shall be designed and specified to withstand operating conditions and duty requirements. All equipment shall be designed considering the following capacity.

S I . N O	Description of bay	Extn. of 765/400/220 kV Ramgarh PS		
		765 kV	400 kV	220 kV
1.	Bus Bar	As per existing	As per existing	As per existing
2.	Line bay	--	3150 A	1600 A
3.	ICT bay	3150 A	3150 A	1600 A

S I . N O	Description of bay	Extn. of 765/400/220 kV Bhadla-III PS		Extn. of 765/400 kV Kanpur (PG) S/s	
		400 kV	220 kV	765 kV	400 kV
1.	Bus Bar	As per existing	As per existing	As per existing	As per existing
2.	Line bay	3150 A	1600 A	--	--
3.	ICT bay	3150 A	1600 A	3150 A	As per existing
4.	Bus Sectionalizer Bay	4000 A	--	--	--

### B.2.1 (765/√3)/ (400/√3)/ 33 kV, Single Phase Autotransformer

500 MVA, (765/√3)/ (400/√3)/ 33 kV, 1-phase Autotransformer (including arrangement for 3-phase bank formation of 1500 MVA) shall conform to CEA's "Standard Specifications and Technical Parameters for Transformers and Reactors (66 kV and above Voltage Class)" as amended up to date available on CEA's website.

Connection arrangement for utilization of existing Spare Single Phase Transformer unit: TSP shall make the arrangement of present Transformer bank in such a way that the existing spare unit can be utilized for Transformer bank under present scope without its physical movement.

### B.2.2 400/220 kV, 3-phase Autotransformer

500 MVA, 400/220 kV, 3-phase Autotransformer shall conform to CEA's "Standard Specifications and Technical Parameters for Transformers and Reactors (66 kV and above Voltage Class)" as amended up to date available on CEA's website.

### B.2.3 765 kV & 220 kV GIS equipment (as applicable)

GIS (Gas Insulated Substation) shall be Indoor type in accordance to IEC: 62271-203.

The switchgear shall be designed and specified to withstand operating conditions and duty requirements. All the switchgear such as Circuit Breaker, isolator, earth switch including CT, PT etc. shall be GIS type. The Surge Arrestor and Voltage Transformer shall be either GIS or outdoor AIS type.

The GIS assembly shall consist of separate modular compartments e.g. Circuit Breaker compartment, Bus bar compartment filled with SF6 Gas and separated by gas tight partitions so as to minimize risk to human life, allow ease of maintenance and limit the effects of gas leaks failures & internal arcs etc. These compartments shall be designed to minimize the risk of damage to adjacent sections and protection of personnel in the event of a failure occurring within the compartments. Rupture diaphragms with suitable deflectors shall be provided to prevent uncontrolled bursting pressures developing within the enclosures under worst operating conditions, thus providing controlled pressure relief in the affected compartment. The arrangement of gas sections or compartments shall be such as to facilitate future extension of any make without any drilling, cutting or welding on the existing equipment. To add equipment, it shall not be necessary to move or dislocate the existing switchgear bays. The layout of Gas Insulated Bus Ducts shall be properly planned to optimize the length of bus ducts and for easy accessibility for maintenance. The length of busbars, bus ducts, isolator sections shall be optimized considering effects of fast transient voltage due to isolator operations.

The bus bar modules including auxiliary bus modules (wherever applicable) shall be provided with suitable End Piece (Interface) module **on both sides** with the test link facility for future extension as per provisions of future requirements. The end piece module shall be designed in such a way so that future GIS modules may be tested without extending test voltage to existing bus and vice-versa by removing the test link.

TSP shall make available the complete details for the design of interface module such as cross section, enclosure material, enclosure dimensions (inner and outer), Flange diameter (inner and outer), conductor cross-section and connection arrangement, bolt spacing & dimension, rated gas pressure, Gasket detail etc. Further, adequate space for GIS busbar interface module shall be taken into account for future scope.

Each section shall have plug-in or easily removable connection pieces to allow for easy replacement of any component with the minimum disturbance to the remainder of the equipment. Inspection windows (View Ports) shall be provided for Disconnect Switches and both type of earth switches i.e. Maintenance and fast operating.

Local Control Cabinets (LCC) shall be provided as per requirement. The alarm & annunciation of GIS equipment shall be wired to the SCADA System.

The material and thickness of the enclosures shall be such as to withstand an internal flashover without burns through for a period of 300 ms at rated short time withstand current. The material shall be such that it has no effect of environment as well as from

the by-products of SF6 breakdown under arcing conditions. This shall be validated with Type Test.

**Service continuity requirement for GIS:**

The GIS equipment with the given bus switching arrangement shall be divided into different gas compartments. During the work such as a fault repair or major maintenance, requiring the dismantling of a gas compartment for which more than one compartments may need to be de-gassed.

TSP shall meet following Service continuity conditions (to the extent possible) with ensuring equipment and operating personnel's safety:

- For One & half breaker bus switching scheme, during a fault in Circuit Breaker compartment, no bus bar and feeder is permitted out of service during maintenance and repair/replacement.
- For Double Main bus switching scheme, during a fault in Circuit Breaker compartment, no bus bar is permitted out of service during maintenance and repair/replacement.
- During a fault in a GIS compartment other than the Circuit Breaker compartment, maximum of one bus bar and/or one feeder is permitted out of service during maintenance and repair/replacement.

**UHF sensors in GIS for PD (Partial Discharge) detection:**

The adequate number of Ultra High Frequency (UHF) sensors shall be provided in the offered GIS along with suitable portable type Partial Discharge (PD) measuring instrument for detection of Partial discharge (of 5 pC and above as per IEC 60270). The number and location of these sensors shall be based on laboratory tests on the typical design of GIS as per recommendations of CIGRE Document No. 654 (Application Guide for sensitivity verification for UHF Partial discharge detection system for GIS).

**B.2.3.1 Circuit Breakers (GIS)**

GIS Circuit breakers shall in general be of C2-M2 class and comply with IEC-62271-100. The rated break time shall not exceed 40 ms for 765 kV and 60 ms for 220 kV. Circuit breakers shall be provided with single phase and three phase auto reclosing. Each breaker would have two sets of trip circuits which would be connected to separate DC supplies for greater reliability. The Circuit breakers controlling 765 kV lines wherever required shall be provided with pre-insertion closing resistor of about 400 ohms with 8 ms insertion time or Controlled Switching Device (CSD) for lines longer than 200 km. The short line fault capacity shall be the same as the rated capacity and this is proposed to be achieved without use of opening resistors. Control Switching Device shall be provided in the Circuit Breaker of switchable line reactor bay and in Main & Tie bay circuit

breakers of line with non-switchable line reactors, Bus reactors & Transformer of 400 kV and above voltage class.

#### **B.2.3.2 Isolators (GIS)**

The isolators shall comply with IEC 62271-102 in general. Earth switches shall be provided at various locations to facilitate maintenance. Main blades and earth blades shall be interlocked, and interlock shall be fail safe type. All isolators and earth switches shall be motor operated type.

The isolator shall be of extended mechanical endurance class-M2 and suitable for Bus Transfer Current Switching duty as per IEC standards. High speed earthing switches shall be provided for grounding purposes at overhead line terminations & cable terminations and shall have fault making capability as specified. Earth switch for line isolator shall be of earthing switch class E1 and shall be suitable for induced current switching duty as defined for Class-B as per relevant standard.

#### **B.2.3.3 Current Transformers (GIS)**

Current Transformers shall comply with IEC 61869 in general. All ratios shall be obtained by secondary taps only. For 400 kV and above voltage class, generally Current Transformers (CT) shall have five cores (four for protection and one for metering) whereas CT in Tie bays shall have six cores (four for protections & two for metering) suitably distributed on both sides of CB. 220 kV Current Transformers (CT) shall have five cores (four for protection and one for metering). The burden and knee point voltage shall be in accordance with the requirements of the system including possible feeds for telemetry. The accuracy class for protection core shall be PX and for metering core it shall be 0.2S. The rated burden of cores shall be closer to the maximum burden requirement of metering and protection system (not more than 20 VA for metering core) for better sensitivity and accuracy.

The instrument security factor shall be less than 5 for CTs up to 400 kV voltage class and less than 10 for CTs of 765 kV voltage class.

#### **B.2.3.4 Voltage Transformers (GIS)**

The voltage transformers shall conform to IEC-61869. Voltage transformers shall be of electromagnetic type with SF6 gas insulation. The earth end of the high voltage winding and the ends of the secondary winding shall be brought out in the terminal box. The voltage transformers shall be located as a separate bay module and will be connected phase to ground and shall be used for protection, metering and synchronization. The voltage transformers shall be of inductive type, nonresistant and shall be contained in their own-SF6 compartment, separated from other parts of installation. The voltage transformer shall be effectively shielded against high frequency electromagnetic transients. The voltage transformer shall have three secondary windings out of which two shall be used for protection and one for metering. The voltage transformer should

be thermally and dielectrically safe when the secondary terminals are loaded with the guaranteed thermal burdens. The accuracy class for protection cores shall be 3P. The accuracy of 0.2 on metering core should be maintained throughout the entire burden range on all the three windings without any adjustments during operation. The rated burden of cores shall be closer to the maximum burden requirement of metering and protection system (not more than 50 VA for metering core) for better sensitivity and accuracy.

#### **B.2.3.5 Surge Arresters (GIS)**

624 kV, 336kV Station High (SH) duty & 216kV Station Medium (SM) duty gapless type Surge arresters with thermal energy ( $W_{th}$ ) of minimum 13 kJ/kV, 12 kJ/kV & 7 kJ/kV conforming to IEC 60099-4 in general shall be provided for 800 kV, 420 kV & 245 kV systems respectively. Other characteristics of Surge arrester shall be chosen in accordance with system requirements. Surge arresters shall be provided at line entrance near Transformers & Reactor so as to achieve proper insulation coordination. Surge Arresters shall be provided with porcelain/ polymer housing fitted with pressure relief devices. A leakage current monitor with surge counter shall be provided with each surge arrester.

#### **B.2.3.6 SF<sub>6</sub> to Air Bushing**

Outdoor bushings, for the connection of conventional external conductors to the SF<sub>6</sub> metal enclosed switchgear, shall be provided. Bushings shall generally be in accordance with the requirements of IEC-60137. The creepage distance over the external surface of outdoor bushings shall not be less than 31 mm/kV. SF<sub>6</sub> to air Bushing shall be of Polymer / composite type and shall be robust and designed for adequate cantilever strength to meet the requirement of seismic conditions. The electrical and mechanical characteristics of bushings shall be in accordance with IEC 60137. Polymer/composite insulator shall be seamless sheath of silicon rubber compound. The housing and weather sheds should have silicon content of minimum 30% by weight. It should protect the bushing against environmental influences, external pollution and humidity. The hollow silicon composite insulators shall comply with the requirements of IEC 61462 and the relevant parts of IEC 62217.

### **B.2.4 765 kV, 400 kV & 200 kV AIS equipment (as applicable)**

#### **B.2.4.1 Circuit Breakers (AIS)**

The circuit breakers and accessories shall conform to IEC: 62271-100, IEC: 62271-1 and shall be of SF<sub>6</sub> Type. The circuit breakers shall be of class C2-M2 (as per IEC) with regard to restrike probability during capacitive current breaking and mechanical endurance. The rated break time shall not exceed 40 ms for 765 kV and 400 kV circuit breakers and 60 ms for 220 kV circuit breakers. The 765 kV, 400 kV and 220 kV Circuit breakers shall be provided with single phase and three phase auto reclosing. Each breaker would have two sets of trip circuits which would be connected to separate DC supplies for greater reliability. The circuit breakers controlling 765 kV lines shall be provided with either pre-

insertion closing resistor of about 450 ohm maximum with 9 ms insertion time or with Controlled Switching Device (CSD). The Circuit breakers controlling 400 kV lines shall be provided with either pre insertion closing resistor of about 400 ohm with 8 ms insertion time or with Controlled Switching Device (CSD) for lines longer than 200 km length. The short line fault capacity shall be same as the rated capacity and this is proposed to be achieved without use of opening resistors. The Controlled Switching Device shall be provided in circuit breakers of switchable line reactor bay and in Main and Tie bay circuit breakers of line with non-switchable line reactors, Bus Reactors and Transformers of 400 kV and above voltage class.

#### **B.2.4.2 Isolators (AIS)**

The Isolators shall comply with IEC 62271-102 in general. 765 kV Isolator design shall be double break or vertical break or knee-type. 400 kV and 220 kV Isolators shall be double break type. All Isolators and earth switches shall be motor operated. Earth switches shall be provided at various locations to facilitate maintenance. Isolator rated for 400 kV and 220 kV shall be of extended mechanical endurance class - M2 as per IEC-62271-102. Isolator rated for 220 kV shall be suitable for bus transfer current switching duty as per IEC-62271-102. Main blades and earth blades shall be interlocked, and interlock shall be fail safe type. The 765 kV, 400 kV and 220 kV earth switch for line isolator shall be suitable for induced current switching duty as defined for Class-B.

#### **B.2.4.3 Current Transformers (AIS)**

Current Transformers shall comply with IEC 61869 in general. All ratios shall be obtained by secondary taps only. Generally, Current Transformers (CT) for 765 kV and 400 kV shall have six cores (four for protection and two for metering) and 220 kV Current Transformers shall have five cores (four for protection and one for metering). The burden and knee point voltage shall be in accordance with the requirements of the system including possible feeds for telemetry. The accuracy class for the protection core shall be PX and for the metering core it shall be 0.2S. The rated burden of cores shall be closer to the maximum burden requirement of the metering and protection system (not more than 20 VA for metering core) for better sensitivity and accuracy. The instrument security factor shall be less than five (5) for CTs up to 400 kV and less than ten (10) for CTs of 765 kV voltage class.

#### **B.2.4.4 Capacitive Voltage Transformers (AIS)**

Capacitive Voltage Transformers shall comply with IEC 61869 in general. These shall have three secondaries out of which two shall be used for protection and one for metering. The accuracy class for protection cores shall be 3P and for metering core shall be 0.2. The Capacitive Voltage Transformers on lines shall be suitable for Carrier Coupling. The Capacitance of CVT for 400 kV and 220 kV shall be of 4400/8800 pF depending on PLCC requirements whereas the Capacitance of CVT for 765 kV shall be 8800 pF. The rated burden of cores shall be closer to the maximum burden requirement of metering and

protection system (not more than 50 VA for metering core) for better sensitivity and accuracy.

#### **B.2.4.5 Surge Arresters (AIS)**

624 kV, 336 kV Station High (SH) duty and 216 kV Station Medium (SM) duty gapless type Surge Arresters with thermal energy (Wth) of minimum 13 kJ/kV, 12 kJ/kV and 7 kJ/kV conforming to IEC 60099-4 in general shall be provided for 800 kV, 420 kV and 245 kV systems respectively. Other characteristics of Surge Arrester shall be chosen in accordance with system requirements. Surge Arresters shall be provided at line entrances, near Transformers and Reactor so as to achieve proper insulation coordination. Surge Arresters shall be provided with porcelain/ polymer housing fitted with pressure relief devices. A leakage current monitor with surge counter shall be provided with each surge arrester.

#### **B.2.5 Protection Relaying and Control System**

The protective relaying system proposed to be provided for transmission lines, auto-transformers, reactors and bus bars to minimize the damage to the equipment in the events of faults and abnormal conditions, is dealt in this section. All main protective relays shall be numerical type with IEC 61850 communication interface and should have interoperability during integration of numerical relays to communicate over IEC 61850 protocol with RTU/SAS/IEDs of different OEMs. All numerical relays shall have built in disturbance recording feature.

The protection circuits and relays of the transformer and reactor shall be electrically and physically segregated into two groups each being independent and capable of providing uninterrupted protection even in the event of one of the protection groups failing, to obtain redundancy, and to take protection systems out for maintenance while the equipment remains in service.

##### **a) Transmission Lines Protection**

765 kV, 400 kV and 220 kV lines shall have Main-I numerical three zone distance protection scheme with carrier aided inter-tripping feature. 765 kV, 400 kV and 220 kV lines shall also have Main-II numerical distance protection scheme like Main-I but from different make that of Main-I. The Main-I and Main-II protection relays of same make may be provided only if they are of different hardware and manufacturing platform or different principle of operation.

However, Line Current Differential Relay (with back up distance protection feature) as Main-I and Main-II shall be considered at both ends for short lines (line length below 30 km) having Fiber Optic Communication Link. Differential relay at remote end shall be provided by the TSP. The associated power and control cabling and integration with SAS at remote end shall be provided by respective bay owners.

In case of 220 kV line bays for RE Generators, Line Current differential relay (with back up distance protection feature) as Main-I and Main-II shall be provided. Further, in such

cases, the matching line current differential relay for remote end shall be provided by the TSP as loose supply. Further, all 765 kV, 400 kV and 220 kV lines shall be provided with single and three phase auto-reclosing facility to allow reclosing of circuit breakers in case of transient faults. These lines shall also be provided with distance to fault locators to identify the location of fault on transmission lines.

All 765 kV and 400 kV lines shall also be provided with two stage over voltage protection. The over voltage protection and distance to fault locator may be provided as in-built feature of Main-I and Main-II protection relays.

Auto reclose as built-in function of Bay Control Unit (BCU) is also acceptable.

The Main-I and Main-II protection relays shall be fed from separate DC sources and shall be mounted in separate panels.

For 765 kV, 400 kV and 220 kV transmission lines, directional IDMT earth fault relay should be provided as standalone unit or in-built feature of Main-I and Main-II feature.

#### **b) Auto Transformer Protection**

These shall have the following protections:

- i) Numerical Differential Protection
- ii) Numerical Restricted Earth Fault Protection
- iii) Numerical Back-up Over-Current and Earth Fault Protection on High Voltage (HV) and Intermediate Voltage (IV) side
- iv) Numerical Over Fluxing Protection on HV and IV side
- v) Numerical Overload Alarm

Further, Numerical Back-up Over-current and earth fault protection on HV and IV side of Autotransformer shall not be combined with other protective functions in the main relays and shall be independent relays. Besides these, power transformers shall also be provided with Buchholz relay, Magnetic Oil Gauge (MOG) with low oil level alarm, protection against high oil and winding temperature and pressure relief device etc.

Suitable monitoring, control (operation of associated circuit breaker and isolator) and protection for LT auxiliary transformer connected to tertiary winding of auto-transformer for the purpose of auxiliary supply shall be provided. The over current and other necessary protection shall be provided for the auxiliary transformer. These protection and control may be provided as built in feature either in the bay controller to be provided for the auxiliary system or in the control and protection IEDs to be provided for autotransformer.

#### **c) Bus Bar Protection**

The high speed low impedance type bus bar differential protection, which is essential to

minimize the damage and maintain system stability at the time of bus bar faults, shall be provided for 765 kV, 400 kV and 220 kV buses. Duplicated bus bar protection is envisaged for 765 kV and 400 kV bus-bar protection. Bus bar protection scheme shall be such that it operates selectively for each bus and incorporate necessary features required for ensuring security.

The scheme shall have complete bus bar protection for present as well as envisaged future bays i.e. input / output modules for future bays for the bus section under present scope shall also be provided.

Bus Bar protection system for new substation shall be de-centralized (distributed) type.

In case, the bus section is provided, then each side of bus section shall have separate set of bus bar protection schemes.

Peripheral Units (PUs) shall be provided by the respective bay owners

For existing substations, the existing bus bar protection shall be augmented as per requirement.

**d) Local Breaker Back up Protection**

This shall be provided for each 765 kV, 400 kV and 220 kV circuit breakers and will be connected to de-energize the affected stuck breaker from both sides.

*Notes:*

- 1) *LBB and REF relays shall be provided separately from transformer differential relay.*
- 2) *LBB relay may also be provided as built-in protection function of distributed bus bar protection scheme; however, in such case separate LBB relay shall be provided for tie bays (in case of One and Half breaker scheme).*
- 3) *Over fluxing and overload protection can be provided as built-in feature of differential relay.*
- 4) *In 765 kV and 400 kV switchyard, if spare bay of half diameter is identified as future, Tie CB relay panel shall be with Auto-reclosure feature.*

**B.2.6 Substation Automation System**

- a) For all the new substations, state of art Substation Automation System (SAS) conforming to IEC-61850 shall be provided. The distributed architecture shall be used for Substation Automation System, where the controls shall be provided through Bay Control Units. The Bay Control Unit is to be provided bay wise for voltage level 220 kV and above. All Bay Control Units as well as protection units are normally connected through an Optical fibre high speed network. The control and monitoring of circuit breaker, disconnector, re-setting of relays etc. can be done from Human Machine Interface (HMI) from the Control Room.

The functions of control, annunciation, disturbance recording, event logging and

measurement of electrical parameters shall be integrated in the Substation Automation System.

At the new substations, the Substation Automation System (SAS) shall be suitable for the operation and monitoring of the complete substation including proposed future bays/elements.

In the existing substations with a Substation Automation System (SAS), augmentation of existing SAS shall be done for bays under the present scope.

In the existing Substations where Substation automation is not provided, control functions shall be done through control panels.

Necessary gateway and modems (as required) shall be provided to send data to RLDC/SLDC as per their requirement and shall be provisioned with 2+2 redundancy i.e. 2 channels for Main Control Centre and 2 channels for Backup Control Centre. In order to meet this requirement, suitable redundancy at port and card level need to be ensured by the TSP to avoid any single point of failure which may lead to interruption in real-time grid operation. Accordingly, all the hardware for communication services of station as stated above shall support dual redundancy for data transmission of station to respective main and backup RLDCs. Any augmentation work at RLDC/SLDC is excluded from TSP's scope. However, all the configuration work at substation end required to send data to RLDC/SLDC shall be in the scope of TSP.

**b) Time Synchronization Equipment**

Time Synchronization Equipment complete in all respect including antenna, cable and processing equipment required to receive time signal through GPS/NavIC or from National Physical Laboratory (NPL) through INSAT shall be provided at new substations. This equipment shall be used to synchronize SAS and IEDs etc.

**B.3.0 Substation Support Facilities**

Certain facilities required for the operation and maintenance of substations as described below shall be provided at the new substation. In existing substation, these facilities have already been provided and will be extended/ augmented as per requirement.

**B.3.1 AC and DC power supplies**

For substation extensions, existing facilities shall be augmented as required.

**B.3.2 Fire Fighting System**

Fire-fighting system for substation including Transformer and Reactor shall conform to

CEA (Measures Relating to Safety and Electric Supply) Regulations, 2023 as amended from time to time.

At existing substations, the fire-fighting systems as available shall be extended to meet the additional requirements.

### **B.3.3 Oil evacuating, Filtering, Testing and Filling apparatus**

To monitor the quality of oil for satisfactory performance of Transformers, Shunt Reactors and for periodical maintenance necessary oil evacuating, filtering, testing and filling apparatus would be provided at new substations. Oil storage tanks of adequate capacities for storage of transformer oil would be provided.

Online Transformer Oil Drying Out System shall be provided in line with the provisions of Standard Specification and Technical Parameters for Transformers and Reactors (66 kV and above Voltage Class) as amended up to date available on CEA website

### **B.3.4 Illumination**

Normal and emergency AC and DC illumination shall be provided adequately in the control room and other buildings of the substation. The switchyard shall also be provided with adequate illumination.

The lighting of the entire control room building, fire-fighting pump house, other building (if any) and switchyard shall be done by LED based low power consumption luminaries.

### **B.3.5 Control Room**

At existing substations, the adequacy of size of control room shall be ascertained and the same shall be augmented as per requirement.

### **B.3.6 GIS hall**

The Gas Insulated Switchgear (GIS) of each voltage level along with other associated equipment shall be housed inside the GIS building. The panels i.e. Bay level units, bay mimic, relay and protection panels, RTCC panels, PLCC panels, panels for telecommunication system etc. are to be placed in a separate room in the GIS building. The size of the room shall be such that all the panels for the bays under present scope shall be accommodated. The panel room shall be air-conditioned. Further, the temperature of the room shall be monitored through substation automation system by providing necessary temperature transducers. Ventilation system of suitable capacity shall be provided for each GIS hall.

One EOT Crane of suitable capacity for erection & maintenance of largest GIS component/assembly and all plant installed in the GIS switchgear room shall be provided in each GIS hall. The crane shall be capable of fulfilling all special requirements for

erection & maintenance of GIS equipment. The capacity of the crane shall be sized to lift the heaviest GIS switchgear component.

For extension of existing GIS, existing facilities shall be suitably augmented/ extended for GIS equipment under present scope.

**B.3.7 Control Concept**

All the EHV circuit breakers in substation/switching stations shall be controlled and synchronized from the switchyard control room/remote control center. All the isolators shall have control from remote/local whereas the earth switches shall have local control only.

**B.3.8 Visual Monitoring System (VMS) for watch and ward of substation premises:**

At existing substations, the Visual Monitoring System if available shall be augmented as per existing or better specification as required.

**B.4.0 General Facilities**

- a) Line Gantry/Towers are envisaged for bays under present scope only. However, for adjacent future line bay, gantry/tower shall be designed for extension (considering Hexa conductors for 765 kV and Quad conductors for 400 kV and Twin conductor for 220 kV future lines) wherever applicable.
- b) Bay extension works at existing substation shall be executed by TSP in accordance with the requirements/provisions mentioned above. However, interface points shall be considered keeping in view the existing design/arrangement at the substation.
- c) TSP has to arrange for construction power and water on its own.
- d) All outdoor steel structures including anchor/foundation bolts shall be fully galvanized. The weight of the zinc coating shall be at least 610 g/m<sup>2</sup> however, for coastal/creek regions it shall be at least 900 g/m<sup>2</sup> (if applicable).
- e) In 765 kV & 400 kV switchyard, if spare bay of half diameter is identified as future, all the equipment for Tie & Future bay shall be designed considering the current rating of line bay i.e. 3150 A.
- f) All electrical equipment shall be installed above the Highest Flood Level (HFL) and where such equipment is not possible to be installed above Highest Flood Level, it shall be ensured that there is no seepage or leakage or logging of water.

**B.5.0 EXTENSION OF EXISTING SUBSTATION**

The following drawings/details of existing substation are attached with the RfP documents for further engineering by the bidder.

Sl. No.	Drawing Title	Drawing No./Details	Rev. No.
<b>A. Bhadla-III PS</b>			
1.0	Single Line Diagram	C/ENGG/SS/BHADLA-3/SLD	00
2.0	General Arrangement	C/ENGG/SS/NR-I/BHADLA - 3/GA	00
3.0	Earthmat Layout	JAK-PGCIL-BAD-400-SYD-EMT-004	00
4.0	Visual Monitoring System	Make : Videonatics Model: NA	--
5.0	Bus Bar Protection	Make : GE Model: P741	--
6.0	Substation Automation System (SAS)	Make : GE	--
<b>B. Ramgarh PS</b>			
1.0	Single Line Diagram	C/ENGG/SS/RAMGARH PS/SLD	--
2.0	General Arrangement	C/ENGG/SS/RAMGARH-II PS/GA DRG	R0
3.0	Earthmat Layout	KEC-SA-409-RMGH-C1-ESE-306-DRG-002	R2
4.0	Visual Monitoring System	Make: Videonetics Model: Videonetics	--
5.0	Bus Bar Protection	Make: GE Model: P741	--
6.0	Substation Automation System (SAS)	Make: GE	--
<b>C. Kanpur (PG) S/s</b>			
1.0	Single Line Diagram	PG/PGCIL/KNP/Slid-drg/001	R4
2.0	General Arrangement	TCE-7320A-740-GA-3011	R7
3.0	Earthmat Layout	TCE-7320A-816-GL-3029	R2
4.0	Visual Monitoring System	Make : Videonatics Model: IVMS 3.0	--
5.0	Bus Bar Protection	Make : Hitachi Model: REB670	--
6.0	Substation Automation System (SAS)	Make : Hitachi Model: MicroSCADA SYS600 Version 10.5	--

**Location details of existing / proposed substation:**

**Bhadla-III PS:** 27° 40' 50.91" N, 72° 11' 52.88" E

**Ramgarh PS:** 27°28'17.89" N, 70°29'38.26" E

**Kanpur (PG) S/s:** 26° 23' 10.309" N, 80° 2' 54.642" E

***Note:** It is to clarify that coordinates/location of S/s indicated is approximate within substation boundary. Exact coordinates for the corresponding bays/gantry for termination of the respective line shall be finalized by the bidder in coordination with site.*

**B.5.1**

The existing drawings provided above and in subsequent amendments to the RfP are as received from the developer of existing substation and provided only for reference. Bidders shall follow the RfP for scope of work. Actual site conditions may be different due to other schemes being executed or subsequent revisions by the developer. Thus, Bidders are advised to visit the substation sites and acquaint themselves for details such as:

- i. Actual site conditions, Layout, Topography
- ii. Infrastructure such as roads, cable trench, drainage
- iii. Space availability in existing control room and LT panel room
- iv. Soil Investigation
- v. Fire Hydrant Layout
- vi. SAS architecture and IO list
- vii. Boundary
- viii. Design philosophy etc.

## **SPECIFIC TECHNICAL REQUIREMENTS FOR COMMUNICATION**

The communication requirement shall be in accordance to CEA (Technical Standards for Communication System in Power System Operations) Regulations, 2020, CEA (Technical Standards for Construction of Electrical Plants and Electric Lines) Regulations, 2022, CERC (Communication System for inter-State transmission of electricity) Regulations, 2017, CEA (Cyber Security in Power Sector) Guidelines, 2021, CEA Guidelines on Unified Philosophy for placement of PMUs in Indian Grid, March 2025 and all above documents as amended from time to time.

The communication services viz. SCADA, AGC (wherever applicable), VoIP, AMR and PMU have been identified as critical services and therefore shall be provisioned with 2+2 redundancy i.e. 2 channels for Main Control Centre and 2 channels for Backup Control Centre. In order to meet this requirement, suitable redundancy at port and card level need to be ensured by the TSP to avoid any single point of failure which may lead to interruption in real-time grid operation.

PMU to PDC communication (wherever required) shall be through 2 channels to the PDC (main) as there is no backup PDC at present.

Accordingly, all the hardware for communication services of station as stated above shall support dual redundancy for data transmission of station to respective main and backup RLDCs

The complete ISTS communication system commissioned by TSP under the RFP shall be the asset of ISTS and shall be available for usage of ISTS requirements as suggested by CTU from time to time.

TSP shall deploy Cyber Security System in compliance with CEA (Cyber Security in Power Sector) Guidelines, 2021 and CEA (Cyber Security in Power Sector) Regulation, from its date of publication/ notification and their amendments thereof.

In order to meet the requirement for grid management and operation of substations, Transmission Service Provider (TSP) shall provide the following:

### **C.1.0 FOTE Requirement for Line bays at Bhadla-III PS**

- (I) TSP shall supply, install & commission FODP with minimum 384 Fiber capacity along with panel and approach Cable (48F each) with all associated hardware fittings from gantry tower to Control Room for all the incoming lines envisaged under the present scope.
- (II) TSP shall supply, install & commission One or more STM-16 (FOTE) equipment along with panel/s supporting minimum eight (8) directions with MSP (Multiplex Section Protection – 1+1). These directions shall exclude protected (1+1) local patching among equipment (if any). Necessary direction shall be provided in FOTE for 5 no. Of 220kV line bays, 1 no. 400kV line bay, however required optical interfaces shall be provided by upcoming entities on this line at the time of connectivity with Bhadla-III PS. The suitable DC Power Supply and backup to be provided for communication equipment.

- (III) FOTE/FODP panel shall be installed in the new Bay Kiosk (Switchyard Panel Room (SPR)). The FOTE under present scope shall be integrated by TSP with the existing FOTE at control room of Bhadla-III PS which shall be communicating with respective control center. TSP to provide necessary FODP sub rack / Splice trays/ Patch cords etc. and optical interfaces/equipment in the existing FOTE/FODP panels in control room for integration with the existing FOTE for onwards data transmission.
- (IV) In case spare optical direction is not available in the existing FOTE at the control room, the TSP shall coordinate with station owner to reconfigure the directions in existing FOTE at control room. Alternatively, The TSP may integrate the FOTE under the present scope with existing FOTE in the nearby Kiosk connected to the control room FOTE (if available with spare direction). For this purpose, TSP shall provide necessary FODP sub rack / Splice trays/ Patch cords etc. and suitable optical interfaces/ equipment in the existing FOTE/FODP panels in another Kiosk (SPR).
- (V) FOTE & FODP Eq can be accommodated in same panel to optimize space.
- (VI) The maintenance of all the communication equipment and software thereof including FOTE, FODP, PMU, approach cable, DCPS along with Battery Bank and cyber security system shall be the responsibility of TSP.

### **C.2.0 FOTE Requirement for line bays at Ramgarh PS**

- (I) TSP shall supply, install & commission FODP with minimum 240 Fiber capacity along with panel and approach Cable (48F each) with all associated hardware fittings from gantry tower to Control Room for all the incoming lines envisaged under the present scope.
- (II) TSP shall supply, install & commission One or more STM-16 (FOTE) equipment along with panel/s supporting minimum Three (5) directions with MSP (Multiplex Section Protection – 1+1). These directions shall exclude protected (1+1) local patching among equipment (if any). Necessary directions shall be provided in FOTE for 2 no. of 220 kV line bay, 1 no. of 400kV line bay, however required optical interfaces shall be provided by upcoming entities on this line at the time of connectivity with Ramgarh PS. A suitable DC Power Supply and backup to be provided for communication equipment.
- (III) FOTE/FODP panel shall be installed in the new Bay Kiosk (Switchyard Panel Room (SPR)). The FOTE under present scope shall be integrated by TSP with the existing FOTE at control room of Ramgarh PS which shall be communicating with respective control center. TSP to provide necessary FODP sub rack / Splice trays/ Patch cords etc. and optical interfaces/equipment in the existing FOTE/FODP panels in control room for integration with the existing FOTE for onwards data transmission.

In case spare optical direction is not available in the existing FOTE at the control room, the TSP shall coordinate with station owner to reconfigure the directions in existing FOTE at control room. Alternatively, The TSP may integrate the FOTE under the present scope with existing FOTE in the nearby Kiosk connected to the control room FOTE (if available with spare direction). For this purpose, TSP shall provide necessary FODP sub

rack / Splice trays/ Patch cords etc. and suitable optical interfaces/ equipment in the existing FOTE/FODP panels in another Kiosk (SPR).

- (IV) FOTE & FODP Eq can be accommodated in same panel to optimize space.
- (V) The maintenance of all the communication equipment and software thereof including FOTE, FODP, PMU, approach cable, DCPS along with Battery Bank and cyber security system shall be the responsibility of TSP.

### **C.3.0 Specific Requirement for Phasor Measurement Units (PMUs)**

TSP shall supply, install and commission required No. of Phasor Measurement Units (PMUs) as per the “Guidelines on Unified Philosophy for placement of PMUs in Indian Grid” issued vide CEA letter No. CEA-PS-14-12/9/2024-PSETD Division dated 19.03.2025 for the scope of this RFP. The PMUs shall be provided with LAN switch and shall connect with LAN switch of control room of respective substations/ generating stations with Fibre Optic cable. The PMUs shall be connected with the FOTE at Substation/ generating stations for onwards data transmission to the PDC (Phasor Data Concentrator) located at respective RLDC. Configuration work in existing PDC at RLDC for new PMU integration shall be done by respective RLDC, however all the necessary support in this regard shall be ensured by TSP. The maintenance of all the PMUs and associated equipment shall be the responsibility of TSP.

Note: Existing Station owner/s to provide necessary support to integrate different equipment and applications of new extended bays with the existing substation e.g. Communication (through FOTE), Voice etc. for smooth operation and monitoring of new added grid elements.

### **C.4.0 Specific Requirement for UNMS Integration of FOTE**

#### **Communication system integration in UNMS/CSMS**

TSP is to ensure integration of communication system into UNMS/CSMS as per following:

“The new communication equipment/ system under the present scope shall be compatible for integration with existing regional level NMS system/ Centralized Supervision & Monitoring System (CSMS) i.e. Regional UNMS. The local configuration of the new communication equipment/ system at the station end shall be the responsibility of TSP as per followings. The configuration work in the existing centralized NMS/ UNMS at Control center end, for integration of new Communication equipment/ system shall be done by Regional ULDC Team/ NMT, however all the necessary support in this regard shall be ensured by TSP.

#### **Requirement for integration of Communication Equipment/ system with Regional UNMS:**

1. TSP shall ensure that NMS/EMS/NE supplied by them is NBI compliant and all FCAPS functionality is supported in the NBI such as NE Inventory, Hardware Inventory– Shelf/Slot/Card/SFP/Port, Topology, Protections, Alarms, Performance-real time and periodic, Performance KPI parameters (E-1, STM, Ethernet), Remote Configuration, Cross Connects, Trails and Circuits, Services Provisioning (NE), E-1, STM, Ethernet, TX and RX Trace, loop back and details are published in the NBI guide for the configuration parameters.

2. TSP shall be obliged to provide/share all necessary documentations such as NBI Guide/MIB/IDL/WSDL/API files etc. for onward integration of their NMS/EMS/NE with regional UNMS.
3. The following support shall be provided by TSP for integration of their supplied equipment with regional UNMS:
  - Enabling and activating NBI license in their EMS/NMS and providing NBI login access along with User credentials
  - Assist in verifying NBI Connectivity with UNMS vendor for the successful communication and retrieval of data.
  - Assist in troubleshooting (if required) for NBI connectivity along with UNMS vendor for the communication and retrieval of data.
4. For standalone NE which is not integrated with any EMS/NMS, TSP shall provide modality of complete FCAPS data acquisition as above through industry standard programmatic methods and provide the CLI command manual.”

**Proposed scheme for "Augmentation with 400/220 kV 5x500 MVA (6th to 10th) ICTs at Bhadla-III PS, 765/400 kV, 2x1500 MVA (3rd & 4th) ICTs & 400/220 kV, 2x500 MVA (3rd & 4th) ICTs at Ramgarh PS and 765/400 kV, 1x1500 MVA (3rd) ICT at Kanpur (PG) S/s"**

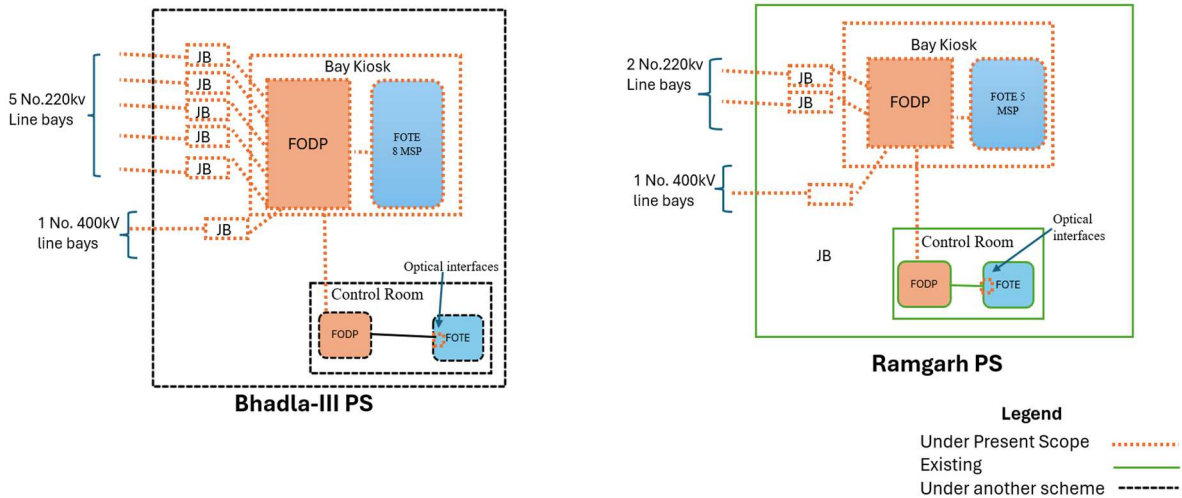

**Figure F.1**

**Frequently Asked Queries:**

**Substation**

- 1.1 We understand that space for storage of O&M spare shall be provided by the existing owner within the station boundary without any cost. Kindly confirm.

**Reply:** Space for storage of O&M spares shall be arranged by TSP on its own.

- 1.2 We presume that the O&M for the end Termination bays will be in the scope of the TSP and TSP shall not be liable for any payment towards O&M to the existing owner of the substation. Kindly confirm.

**Reply:** Operation and maintenance of the bays is solely the responsibility of the TSP. Further, TSP shall follow CEA's "Operation and Maintenance (O&M) guidelines and Standard Format for Memorandum of Understanding between New TSP and Existing TSP" issued by CEA vide its letter No. I/28514/2023 dated 22.06.2023.

- 1.3 With reference to subject scheme of existing sub-station, we assumed following scope of work:

- (a) We assumed internal road is available and need not to be consider in the present scope of work.
- (b) Drainage is available and need not to consider in the present scope of work.
- (c) Cable trench extension adjacent to Main cable trench only under present scope of work.
- (d) Levelled area being provided by developer for bay extension.

**Reply:** Regarding requirement of internal road, drainage, cable trench, leveling of the bay extension area, bidder is advised to visit site and acquaint themselves with the provisions/facilities available at substation.

- 1.4 Kindly provide the soil investigation report of soil parameters of existing substation.

**Reply:** Bidder is advised to visit the substation site and ascertain the requisite parameters.

- 1.5 Kindly confirm, energy accounting of aux. power consumption. Whether it will be on chargeable basis or part of transmission loss.

**Reply:** It will be on a chargeable basis.

- 1.6 We understand that VMS requirement is for unmanned stations only. For Manned stations VMS is not compulsory.

**Reply:** VMS shall be provided in line with requirements of RfP document.

- 1.7 It is understood that Construction water and power shall be provided free of cost to TSP by the respective substation owner for construction of new bays.

**Reply:** Arrangement of construction power and water is in the scope of TSP.

- 1.8 It is understood that the existing fire hydrant system shall be extended by the TSP for bay extension.

**Reply:** Existing fire hydrant system shall be extended from existing system (if required)

- 1.9 Please clarify the Status of land acquisition for new Substations. Whether the lands have been acquired by BPC and will be transferred to TSP.

**Reply:** The acquisition of land for new substation is in the scope of TSP.

- 1.10 We understood that no any dedicated metering CT and CVT required for Line/feeders. Further, we understood that requisite Energy meters for various 765 kV, 400 kV and 220 kV Feeders shall be provided and installed by CTU free of cost to TSP.

**Reply:** Dedicated metering CT and CVT are not required for line/feeders. Metering core of existing CT/CVT can be used provided accuracy class matches with metering requirement. Requisite Special Energy Meters shall be provided and installed by CTU at the cost of TSP in C&P panel subject to space availability, else, in separate metering panel (to be provided by TSP at its cost).

- 1.11 A draft copy of the Connection Agreement may be furnished. A draft copy of the Connection Agreement may be furnished.

**Reply:** Web page link [https://www.ctuil.in/formats\\_gna\\_transition](https://www.ctuil.in/formats_gna_transition)

- 1.12 Please clarify whether the spare 765 kV single phase Reactor unit for Bus reactor shall be provided with 1ph 765 kV CB.

**Reply:** As per RfP, the spare 1-Ph reactor unit shall be utilized for all the bus and switchable line reactor banks (including for future reactor banks). Hence, 1ph 765 kV CB shall also be provided with spare 1-Ph reactor for utilizing with bus reactor as well as switchable line reactor.

- 1.13 It is understood that existing busbar protection has provision for future bays and also PUs are available for future bays. BPC to confirm availability of CU and PU for bays under present scope of work at existing substations. BPC may kindly confirm availability of communication ports for integrating new PUs with the existing CUs at existing substations.

**Reply:** Bus Bar Protection with Central Unit (CU) is required for the new bus section as specified in RfP. Peripheral Units (PUs) shall be provided by the respective bay owner.

Further, augmentation/replacement of existing CU, if required, to meet the system requirement shall also be provided for proper functioning of bus bar protection.

- 1.14 For SCADA, it is understood that necessary process I/O shall be available for future bays and accordingly license for same. BPC to confirm.

**Reply:** Necessary process I/O along with license shall be in the scope of the successful bidder.

- 1.15 No separate FF system is envisaged under the present scope of work for existing substation. BPC to confirm.

**Reply:** Existing fire-fighting systems shall be extended to meet the additional requirements under present scope.

- 1.16 PLCC for 220 kV Lines are not under the scope of TSP. BPC to Confirm. It is requested to provide Type of Coupling for 220 kV Transmission Lines under present scope.

**Reply:** PLCC for 220 kV line is in the scope of developer of the line.

Inter circuit coupling for 220 kV D/C and phase to phase coupling for 220 kV S/C shall be applicable for PLCC.

- 1.17 BPC is requested to confirm the availability of space in the existing control rooms at existing substation for execution of extension work under current project.

**Reply:** Switchyard Panel Rooms are generally required for AIS type substation and relay room are required for GIS type substation. Further, if needed, the control room shall be augmented as per requirement.

## Communication

- 2.1 What are the usage of OPGW, FOTE, PMU etc. under communication requirement Of RFP?

**Reply:** User shall be responsible for providing compatible equipment along with appropriate interface for uninterrupted communication with the concerned control center and shall be responsible for successful integration with the communication system provided by CTU.

Communication systems e.g. OPGW, FOTE etc. and PMU are required for grid operation through RLDC/SLDC, speech communication, tele-protection and tele-metering.

- 2.2 Is space for installation of communication panels are provided to TSP in existing Substations incase new bays are in the scope of TSP?

**Reply:** The space related issues are deliberated in the RfP itself. TSP to install FOTE/FODP panels in the new Bay Kiosk (Switchyard Panel Room (SPR)) / Bay Kiosk/ Relay Panel Room (in case of GIS S/s). Further, TSP to connect and integrate the proposed FOTE with

the existing FOTE in the control room to complete the communication path upto RLDC.

In Case 132 kV Substation TSP shall accommodate the said panels either by extension of existing control room or other arrangements.

2.3 How is the OPGW laying done in case of LILO lines?

**Reply:**

In case LILO lines are on same towers (e.g. both Line in and Line Out portion are on same towers, generally done LILO of S/C lines). Then one No. OPGW having fibers equal to no of fibers in main line OPGW shall be required to be install by TSP on both earthwire peak on 400 kV and 765 kV lines where two E/W peaks are available. On 220 kV and 132 kV lines where only one E/W peak is available TSP to install one No. OPGW having fibers double the No. of fibers in main line OPGW.

In case LILO lines are on different towers (e.g. both Line In and Line Out portion are on different towers, generally done LILO of D/C lines). Then one No. OPGW having fibers equal to no of fibers in main line OPGW shall be required to be install by TSP on one earthwire peak and conventional earthwire on second earthwire peak, on both Line In and Line Out portion towers of 400 kV and 765 kV lines. On 220 kV and 132 kV lines where only one E/W peak is available TSP to install one No. OPGW having fibers equal to no of fibers in main line OPGW in place of conventional earthwire.

2.4 How is the OPGW laying done in the case of Multi circuit Towers?

**Reply:**

In case two different lines are using common multi circuit portion for some distance (originating from different stations, may be terminating on same or on different stations), Then OPGW having fibers equal to fibers laid on different lines to be installed on both E/W peaks for common M/C portion of 765 kV & 400 kV lines by the TSP. In case 220/132 kV lines using multi circuit portion where single E/W peak is available, required OPGW to accommodate all the OPGW fibers of different transmission lines may be installed for common multi circuit portion.

2.5 How PMUs are integrated for new bays at existing Substations?

**Reply:** PMU data of new bays to be provided in the ethernet port of switch at control room and thereafter to be connected with existing FOTE of existing substation to send data to PDC of RLDC by TSP. These PMUs shall be provided with GPS clock and LAN switch and shall connect with LAN switch of control room of respective substations with Fiber Optic cable. In this regard, the "Guidelines on Unified Philosophy for placement of PMUs in Indian Grid" issued vide letter No. CEA-PS-14-12/9/2024-PSETD Division dated 19.03.2025 shall be followed.

2.6 Is Spare direction available in existing FOTE for integration with new bay kiosk FOTE

**Reply:** The FOTE under present scope shall be integrated by TSP with the existing FOTE at control room of substation for onwards data transmission. In case spare optical direction is not available in the existing FOTE at the control room, the TSP shall coordinate with station owner to reconfigure the directions in existing FOTE at control room.

2.7 What is the distance from LILO point to proposed substation for feasibility of repeater station?

**Reply:** Tentative Location of LILO point shall be as per survey report of BPC however exact location to be ascertained after detailed survey by TSP.

2.8 What is the make and model of existing OPGW in case LILO of main line at new substation?

**Reply:** All OPGW (alongwith optical fibers) meet Central Electricity Authority (Technical Standards for Communication System in Power System Operations) Regulations, 2020 and bidder shall install OPGW accordingly.

2.9 In case of LILO of existing line at new substation who shall provide PMUs at existing substation bays?

**Reply:** TSP shall provide the PMUs for the scope under RfP in compliance of "Guidelines on Unified Philosophy for placement of PMUs in Indian Grid" issued vide letter No. CEA-PS-14-12/9/2024-PSETD Division dated 19.03.2025.

### **Planning:**

3.1 Whether the Project/ Elements are eligible for early commissioning incentive as per MoP, Gol order dated 15.07.2015.?

**Reply:** Commissioning is to be done as per the timeline mentioned in RfP. However, early commissioning shall be treated as per applicable CERC Regulations/orders.

**Schedule: 2**  
**Scheduled COD**

**[Note: As referred to in the definition of “Element”, “Scheduled COD”, and in Article 3.1.3 (c), 4 (b) and 4.3 (a) of this Agreement]**

Sl. No.	Name of the Transmission Element	Scheduled COD*	Percentage of Quoted Transmission Charges recoverable on Scheduled COD of the Element of the Project**	Element(s) which are pre-required for declaring the commercial operation (COD) of the respective element
1.	Augmentation of 400/220 kV, 5x500 MVA (6 <sup>th</sup> to 10 <sup>th</sup> ) ICTs at 765/400/220 kV Bhadla-III PS	20.01.2029 (matching with timeframe of Transmission System for Evacuation of Power from REZ in Rajasthan (20 GW) under Phase III – Part I scheme (Pole 1))	36.4%	These elements of the scheme are required to be commissioned simultaneously as their utilization is dependent on each other.
2.	Implementation of 5 Nos. of 220 kV line bays at 765/400/220 kV Bhadla-III PS.			
3.	Implementation of 1 No. of 400 kV line bay at 765/400/220 kV Bhadla-III PS.			
4.	Implementation of 2 sets 400 kV sectionlizer bay at 765/400/220 kV Bhadla-III PS			
5.	Augmentation of 765/400 kV, 2x1500 MVA (3 <sup>rd</sup> & 4 <sup>th</sup> ) ICTs at 765/400/220 kV Ramgarh PS		39.6%	These elements of the scheme are required to be commissioned simultaneously
6.	Augmentation of 400/220 kV, 2x500 MVA (3 <sup>rd</sup> & 4 <sup>th</sup> )			

Sl. No.	Name of the Transmission Element	Scheduled COD*	Percentage of Quoted Transmission Charges recoverable on Scheduled COD of the Element of the Project**	Element(s) which are pre-required for declaring the commercial operation (COD) of the respective element
	ICTs at 765/400/220 kV Ramgarh PS			as their utilization is dependent on each other.
7.	Implementation of 2 Nos. of 220 kV line bays at 765/400/220 kV Ramgarh PS			
8.	Implementation of 1 No. of 400 kV line bay at 765/400/220 kV Ramgarh PS			
9.	Augmentation of 765/400 kV, 1x1500 MVA (3 <sup>rd</sup> ) ICT at 765/400 kV Kanpur (PG) substation		24%	Utilization of this Element is independent

The payment of Transmission Charges for any Element, irrespective of its successful commissioning on or before its Scheduled COD, shall only be considered after successful commissioning of the Element(s), which are pre- required for declaring the commercial operation of such Element as mentioned in the above table.

**Scheduled COD for the Project is:** 20.01.2029 (matching with timeframe of Transmission System for Evacuation of Power from REZ in Rajasthan (20 GW) under Phase III – Part I scheme (Pole 1)).

**Schedule: 3**

**Safety Rules and Procedures**

**[Note: As referred to in Articles 5.6 of this Agreement]**

**1: Site Regulations and Safety:**

The TSP shall establish Site regulations within sixty (60) days from fulfilment of conditions subsequent, as per Prudent Utility Practices setting out the rules to be observed till expiry of the Agreement at the Site and shall comply therewith.

Such Site regulations shall include, but shall not be limited to, rules in respect of security, safety of the Project, gate control, sanitation, medical care, and fire prevention, public health, environment protection, security of public life, etc.

Copies of such Site regulations shall be provided to the Nodal Agency and the CEA for the purpose of monitoring of the Project.

**2: Emergency Work:**

In cases of any emergency, the TSP shall carry out all necessary remedial work as may be necessary.

If the work done or caused to be done by any entity , other than the TSP, the TSP shall, reimburse the actual costs incurred, to the other Party carrying out such remedial works.

**3: Site Clearance:**

In the course of execution of the Agreement, the TSP shall keep the Site reasonably free from all unnecessary obstruction, storage, remove any surplus materials, clear away any wreckage, rubbish and temporary works from the Site, and remove any equipment no longer required for execution of the Agreement. After completion of all Elements of the Project, the TSP shall clear away and remove all wreckage, rubbish and debris of any kind from the Site, and shall leave the Site clean and safe.

**4: Watching and Lighting:**

Transmission Service Agreement

The TSP shall provide and maintain at its own expense all lighting, fencing, and watching when and where necessary for the proper construction, operation, maintenance / repair of any of the Elements of the Project, or for the safety of the owners and occupiers of adjacent property and for the safety of the public, during such maintenance / repair.

**Schedule: 4****Computation of Transmission Charges****1.1 General**

The Monthly Transmission Charges to be paid to the TSP for providing Transmission Service for any Contract Year during the term of the Agreement shall be computed in accordance with this Schedule and paid as per Sharing Regulations.

Illustration regarding payment of Transmission Charges under various scenarios (considering definitions of Contract Year, Expiry Date & Monthly Transmission Charges above) is as below: -

**Illustration-1: In case the Project Elements achieve COD as per Schedule**

Quoted Transmission Charges: **Rs. 140 Million**

Completion Schedule:

Element No.	Completion Schedule in Months	Scheduled CoD of the Element	Actual CoD of the Element	% Charges recoverable on Scheduled CoD of the Element
Element 1	28	1-Feb-2018	1-Feb-2018	25%
Element 2	38	1-Dec-2018	1-Dec-2018	75%

Tariff Payable as follows:

Transmission Charges for Element 1			Transmission Charges for Element 2		
1-Feb-18 to 31-Mar-18	$140 \times 25\% \times ((28+31)/365)$	5.65		--	0.00
1-Apr-18 to 30-Nov-18	$140 \times 25\% \times (244/365)$	23.39		--	0.00
1-Dec-18 to 31-Mar-19	$140 \times 100\% \times (121/365)$				46.41
2	$140 \times 100\% \times 1$				140
3	$140 \times 100\% \times 1$				140
4	$140 \times 100\% \times 1$				140
5	$140 \times 100\% \times 1$				140
.....					
.....					
36 (1-Apr to 30-Nov)	$140 \times 100\% \times (244/365)$				93.59

**Illustration-2: In case of extension of Scheduled COD as per Article 4.4.1 & 4.4.2 of this Agreement**Quoted Transmission Charges: **Rs. 140 Million**

Completion Schedule:

Element No.	Completion Schedule in Months	Scheduled CoD of the Element	Actual CoD of the Element	% Charges recoverable on Scheduled CoD of the Element
Element 1	20	1-Feb-2018	1-Jul-2018	25%
Element 2	28	1-Oct-2018	1-Dec-2018	75%

Tariff Payable as follows:

Transmission Charges for Element 1			Transmission Charges for Element 2		
1-Feb-18 to 31-Mar-18	--	0.00		--	0.00
1-Apr-18 to 30-Jun-18	--	0.00		--	0.00
1-Jul-18 to 30-Nov-18	140 X 25% X (153/365)	14.67		--	0.00
1-Dec-18 to 31-Mar-19	140 X 100% X (121/365)				46.41
2	140 X 100% X 1				140
3	140 X 100% X 1				140
4	140 X 100% X 1				140
5	140 X 100% X 1				140
.....					
.....					
36 (1-Apr to 30-Nov)	140 X 100% X (244/365)				93.59

**Illustration-3: In case of delay in achieving COD of Project & all individual Elements (COD of the Project achieved in Contract Year 1)**Quoted Transmission Charges: **Rs. 140 Million**

Completion Schedule:

Element No.	Completion Schedule in Months	Scheduled CoD of the Element	Actual CoD of the Element	% Charges recoverable on Scheduled CoD of the Element
Element 1	20	1-Feb-2018	1-Dec-2018	25%
Element 2	28	1-Oct-2018	1-Dec-2018	75%

Tariff Payable as follows:

Transmission Charges for Element 1			Transmission Charges for Element 2		
1-Feb-18 to 31-Mar-18	--	0.00		--	0.00
1-Apr-18 to 30-Sept-18	--	0.00		--	0.00
1-Oct-18 to 30-Nov-18	--	0.00	1-Oct-18 to 30-Nov-18	--	0.00
1-Dec-18 to 31-Mar-19	140 X 100% X (121/365)				46.41
2	140 X 100% X 1				140
3	140 X 100% X 1				140
4	140 X 100% X 1				140
5	140 X 100% X 1				140
.....					
.....					
36 (1-Apr to 30-Nov)	140 X 100% X (244/365)				93.59

**Illustration-4: In case of delay in achieving COD of Project & all individual Elements (COD of the Project achieved in Contract Year other than Contract Year 1)**

Quoted Transmission Charges: **Rs. 140 Million**

Completion Schedule:

Element No.	Completion Schedule in Months	Scheduled CoD of the Element	Actual CoD of the Element	% Charges recoverable on Scheduled CoD of the Element
Element 1	38	1-Oct-2019	1-May-2020	25%
Element 2	38	1-Oct-2019	1-May-2020	75%

Tariff Payment to be paid as:

Transmission Charges for Element 1			Transmission Charges for Element 2		
1-Oct-19 to 31-Mar-20	--	0.00	1-Oct-19 to 31-Mar-20	--	0.00
1-Apr-20 to 30-Apr-20	-	0.00	1-Apr-20 to 30-Apr-20	-	0.00
1-May-20 to 31-Mar-21	140 X 100% X (335/365)				128.49
2	140 X 100% X 1				140
3	140 X 100% X 1				140
4	140 X 100% X 1				140
5	140 X 100% X 1				140
.....					
.....					
36 (1-Apr to 30-Apr)	140 X 100% X (30/ 365)				11.51

**Illustration5: In case of delay in achieving COD of Element but Project COD achieved on time**Quoted Transmission Charges: **Rs. 140 Million**

Completion Schedule:

Element No.	Completion Schedule in Months	Scheduled CoD of the Element	Actual CoD of the Element	% Charges recoverable on Scheduled CoD of the Element
Element 1	20	1-Feb-2018	1-Jul-2018	25%
Element 2	30	1-Dec-2018	1-Dec-2018	75%

Tariff Payable as follows:

Transmission Charges for Element 1			Transmission Charges for Element 2		
1-Feb-18 to 31-Mar-18	--	0.00		--	0.00
1-Apr-18 to 30-Jun-18	--	0.00		--	0.00
1-Jul-18 to 30-Nov-18	140 X 25% X (153/365)	14.67		--	0.00
1-Dec-18 to 31-Mar-19	140 X 100% X (121/365)				46.41
2	140 X 100% X 1				140
3	140 X 100% X 1				140
4	140 X 100% X 1				140
5	140 X 100% X 1				140
.....					
.....					
36 (1-Apr to 30-Nov)	140 X 100% X (244/365)				93.59

**Illustration-6: In case of early commissioning of Project**

Quoted Transmission Charges: **Rs. 140 Million**

Completion Schedule:

Element No.	Completion Schedule in Months	Scheduled CoD of the Element	Actual CoD of the Element	% Charges recoverable on Scheduled CoD of the Element
Element 1	38	1-Oct-2019	1-Jul-2019	25%
Element 2	38	1-Oct-2019	1-Jul-2019	75%

Tariff Payment to be paid as:

Transmission Charges for Element 1		Transmission Charges for Element 2	
1-July-19 to 31-Mar-20	140 X 100% X (274/365)		105.09
2	140 X 100% X 1		140
3	140 X 100% X 1		140
4	140 X 100% X 1		140
5	140 X 100% X 1		140
.....			
.....			
36 (1-Apr to 30-Jun)	140 X 100% X (91/365)		34.91

**Illustration-7: In case of early commissioning of an element**

Quoted Transmission Charges: **Rs. 140 Million**

Completion Schedule:

Element No.	Completion Schedule in Months	Scheduled CoD of the Element	Actual CoD of the Element	% Charges recoverable on Scheduled CoD of the Element
Element 1	38	1-Oct-2019	1-Apr-2019	25%
Element 2	38	1-Jul-2019	1-Jul-2019	75%

Tariff Payment to be paid as:

Transmission Charges for Element 1			Transmission Charges for Element 2		
1-Apr-2019 to 30-Jun-19	140 X 25% X (91/365)	8.72	1-Apr-2019 to 30-Jun-19	--	0.00
1-July-19 to 31-Mar-20	140 X 100% X (274/ 365)				105.09
2	140 X 100% X 1				140
3	140 X 100% X 1				140
4	140 X 100% X 1				140
5	140 X 100% X 1				140
.....					
.....					
36 (1-Apr-30-Jun)	140 X 100% X (91/365)				34.91

The Transmission Charges shall be payable on monthly basis as computed above.

**1.2 Computation of Monthly Transmission Charges**

The Monthly Transmission Charges for any month m in a Contract Year n shall be calculated as below:

For AC System:

- a. If Actual Transmission System Availability for the month m of contract year n is greater than or equal to 98% and less than or equal to 98.5%;

$$\text{Monthly Transmission Charges MTC}(m) = T_{mn} * 1$$

- b. If Actual Transmission System Availability for the month m of contract year n exceeds 98.5% and less than or equal to 99.75%;

$$\text{Monthly Transmission Charges MTC}(m) = T_{mn} * (AA / 98.5\%)$$

- c. If Actual Transmission System Availability for the month m of contract year n is greater than 99.75%;

$$\text{Monthly Transmission Charges MTC}(m) = T_{mn} * (99.75\% / 98.5\%)$$

- d. If Actual Transmission System Availability for the month m of contract year n is less than 98% and greater than or equal to 95.00%;

$$\text{Monthly Transmission Charges MTC}(m) = T_{mn} * (AA / 98\%)$$

- e. If Actual Transmission System Availability for the month m of contract year falls below 95%;

$$\text{Monthly Transmission Charges MTC}(m) = T_{mn} * (AA/ 98\%) - 0.02 * (T_{mn} * (AA/ 95\%))$$

For DC System:

- a. If Actual Transmission System Availability for the month m of contract year n is greater than or equal to 95% and less than or equal to 96%;

$$\text{Monthly Transmission Charges MTC}(m) = T_{mn} * 1$$

- b. If Actual Transmission System Availability for the month m of contract year n exceeds 96% and less than or equal to 99.75%;

$$\text{Monthly Transmission Charges MTC}(m) = T_{mn} * (AA/ 96\%)$$

- c. If Actual Transmission System Availability for the month m of contract year n is greater than 99.75%;

$$\text{Monthly Transmission Charges MTC}(m) = T_{mn} * (99.75\% / 96\%)$$

- d. If Actual Transmission System Availability for the month m of contract year n is less than 95% and greater than or equal to 92.00%;

$$\text{Monthly Transmission Charges MTC}(m) = T_{mn} * (AA/ 95\%)$$

- e. If Actual Transmission System Availability for the month m of contract year falls below 92%;

$$\text{Monthly Transmission Charges MTC}(m) = T_{mn} * (AA/ 95\%) - 0.02 * (T_{mn} * (AA/ 92\%))$$

where:

- AA is the actual Availability, as certified by RPC, as per procedure provided in Schedule 6.
- m is the month in Contract Year 'n'
- $T_{mn} = \text{Transmission Charges for the month 'm' in Contract Year 'n' } = (\text{Transmission Charge/ no. of days in the Year n}) * \text{no. of days in month m}$

Provided, no Transmission Charges shall be paid during the period for which the RLDC has not allowed the operation of the Element/Project due to the failure of the TSP to operate it as per the provisions of the Grid Code.

**1.3 RLDC Fee & Charges**

The payment of RLDC fee & charges, in accordance with relevant regulations of CERC, shall be the responsibility of the TSP.

**Schedule: 5****Quoted Transmission Charges**

**[Quoted Transmission Charges from Annexure - 21 of the RFP of the Selected Bidder to be inserted here]**

**[To be incorporated from the Bid of the Selected Bidder submitted during the e-reverse auction after its selection]**

**Quoted Transmission Charges: Rs..... Million**

**Proportionate Transmission Charges payable for each Element of the Project:**

<b>Sl. No.</b>	<b>Name of the Transmission Element</b>	<b>Percentage of Quoted Transmission Charges recoverable on Scheduled COD of the Element of the Project**</b>	<b>Element(s) which are pre-required for declaring the commercial operation (COD) of the respective element</b>
1.	Augmentation of 400/220 kV, 5x500 MVA (6 <sup>th</sup> to 10 <sup>th</sup> ) ICTs at 765/400/220 kV Bhadla-III PS	36.4%	These elements of the scheme are required to be commissioned simultaneously as their utilization is dependent on each other.
2.	Implementation of 5 Nos. of 220 kV line bays at 765/400/220 kV Bhadla-III PS.		
3.	Implementation of 1 No. of 400 kV line bay at 765/400/220 kV Bhadla-III PS.		
4.	Implementation of 2 sets 400 kV sectionlizer bay at 765/400/220 kV Bhadla-III PS		
5.	Augmentation of 765/400 kV, 2x1500 MVA (3 <sup>rd</sup> & 4 <sup>th</sup> ) ICTs at 765/400/220 kV	39.6%	

Sl. No.	Name of the Transmission Element	Percentage of Quoted Transmission Charges recoverable on Scheduled COD of the Element of the Project**	Element(s) which are pre-required for declaring the commercial operation (COD) of the respective element
	Ramgarh PS		simultaneously as their utilization is dependent on each other.
6.	Augmentation of 400/220 kV, 2x500 MVA (3 <sup>rd</sup> & 4 <sup>th</sup> ) ICTs at 765/400/220 kV Ramgarh PS		
7.	Implementation of 2 Nos. of 220 kV line bays at 765/400/220 kV Ramgarh PS		
8.	Implementation of 1 No. of 400 kV line bay at 765/400/220 kV Ramgarh PS		
9.	Augmentation of 765/400 kV, 1x1500 MVA (3 <sup>rd</sup> ) ICT at 765/400 kV Kanpur (PG) substation	24%	Utilization of this Element is independent

**Schedule: 6**

**Appendix -IV to the Central Electricity Regulatory Commission (Terms and Conditions of Tariff) Regulations 2024**

**Procedure for Calculation of Transmission System Availability Factor for a Month**

1. Transmission system availability factor for nth calendar month (“TAFPn”) shall be calculated by the respective transmission licensee, verified by the concerned Regional Load Dispatch Centre (RLDC) and certified by the Member-Secretary, Regional Power Committee of the region concerned, separately for each AC and HVDC transmission system and grouped according to sharing of transmission charges. In the case of the AC system, transmission System Availability shall be calculated separately for each Regional Transmission System and inter-regional transmission system. In the case of the HVDC system, transmission System Availability shall be calculated on a consolidated basis for all inter-state HVDC systems.
2. Transmission system availability factor for nth calendar month (“TAFPn”) shall be calculated by considering the following:
  - i) **AC transmission lines:** Each circuit of AC transmission line shall be considered as one element;
  - ii) **Inter-Connecting Transformers (ICTs):** Each ICT bank (three single-phase transformers together) shall form one element;
  - iii) **Static VAR Compensator (SVC):** SVC, along with SVC transformer, shall form one element;
  - iv) **Bus Reactors or Switchable line reactors:** Each Bus Reactors or Switchable line reactors shall be considered as one element;
  - v) **HVDC Bi-pole links:** Each pole of the HVDC link, along with associated equipment at both ends, shall be considered as one element;
  - vi) **HVDC back-to-back station:** Each block of the HVDC back-to-back station shall be considered as one element. If the associated AC line (necessary for the transfer of inter-regional power through the HVDC back-to-back station) is not available, the HVDC back-to-back station block shall also be considered unavailable;
  - vii) **Static Synchronous Compensation (“STATCOM”):** Each STATCOM shall be considered as a separate element.

3. The Availability of the AC and HVDC portion of the Transmission system shall be calculated by considering each category of transmission elements as under:

**TAFPn (in %) for AC system:**

$$= \frac{(o \times AV_o) + (p \times AV_p) + (q \times AV_q) + (r \times AV_r) + (u \times AV_u)}{(o + p + q + r + u)} \times 100$$

Where,

- o = Total number of AC lines.
- AV<sub>o</sub> = Availability of o number of AC lines
- p = Total number of bus reactors/switchable line reactors
- AV<sub>p</sub> = Availability of p number of bus reactors/switchable line reactors
- q = Total number of ICTs
- AV<sub>q</sub> = Availability of q number of ICTs
- r = Total number of SVCs
- AV<sub>r</sub> = Availability of r number of SVCs
- u = Total number of STATCOM
- AV<sub>u</sub> = Availability of u number of STATCOM

**TAFMn (in %) for HVDC System:**

$$= \frac{\sum_{x=1}^s C_{xpb}(\text{act}) \times AV_{xpb} + \sum_{y=1}^t C_{ybtb}(\text{act}) \times AV_{ybtb}}{\sum_{x=1}^s C_{xpb} + \sum_{y=1}^t C_{ybtb}} \times 100$$

Where

- C<sub>xpb</sub>(act) = Total actual operated capacity of x<sup>th</sup> HVDC pole
- C<sub>xpb</sub> = Total rated capacity of x<sup>th</sup> HVDC pole
- AV<sub>xpb</sub> = Availability of x<sup>th</sup> HVDC pole
- C<sub>ybtb</sub>(act) = Total actual operated capacity of y<sup>th</sup> HVDC back-to-back station block
- C<sub>ybtb</sub> = Total rated capacity of y<sup>th</sup> HVDC back-to-back station block
- AV<sub>ybtb</sub> = Availability of y<sup>th</sup> HVDC back-to-back station block
- s = Total no of HVDC poles
- t = Total no of HVDC Back to Back blocks

4. The availability for each category of transmission elements shall be calculated based on the weightage factor, total hours under consideration and non-available hours for each element of that category. The formulae for calculation of the Availability of each category of the transmission elements are as per **Appendix-V**. The weightage factor for each category of transmission elements shall be considered as under:
  - (a) For each circuit of the AC line – The number of sub-conductors in the line multiplied by ckt-km;
  - (b) For each HVDC pole- The rated MW capacity x ckt-km;
  - (c) For each ICT bank – The rated MVA capacity;
  - (d) For SVC- The rated MVAR capacity (inductive and capacitive);
  - (e) For Bus Reactor/switchable line reactors – The rated MVAR capacity;
  - (f) For HVDC back-to-back stations connecting two Regional grids- Rated MW capacity of each block; and
  - (g) For STATCOM – Total rated MVAR Capacity.
  
5. The transmission elements under outage due to the following reasons shall be deemed to be available:
  - i. Shut down availed for maintenance of another transmission scheme or construction of new element or renovation/upgradation/additional capitalization in an existing system approved by the Commission. If the other transmission scheme belongs to the transmission licensee, the Member Secretary, RPC may restrict the deemed availability period to that considered reasonable by him for the work involved. In case of a dispute regarding deemed availability, the matter may be referred to the Chairperson, CEA, within 30 days.
  - ii. Switching off of a transmission line to restrict over-voltage and manual tripping of switched reactors as per the directions of the concerned RLDC.
  - iii. Shut down of a transmission line due to the Project(s) of NHAI, Railways and Border Road Organization, including for shifting or modification of such transmission line or any other infrastructure project approved by Ministry of Power. Member Secretary, RPC may restrict the deemed availability period to that considered reasonable by him for the work involved; Provided that apart from the deemed availability, any other costs involved in the process of such shutdown of transmission line shall not be borne by the DICs.

Provided that such deemed availability shall be considered only for the period for which DICs are not affected by the shutdown of such transmission line.

6. For the following contingencies, the outage period of transmission elements, as certified by the Member Secretary, RPC, shall be excluded from the total time of the element under the period of consideration for the following contingencies:
  - i) Outage of elements due to force majeure events beyond the control of the transmission licensee. However, whether the same outage is due to force majeure (not design failure) will be verified by the Member Secretary, RPC. A reasonable restoration time for the element shall be considered by the Member Secretary, RPC, and any additional time taken by the transmission licensee for restoration of the element beyond the reasonable time shall be treated as outage time attributable to the transmission licensee. Member Secretary, RPC may consult the transmission licensee or any expert for estimation of reasonable restoration time. Circuits restored through ERS (Emergency Restoration System) shall be considered as available;
  - ii) Outage caused by grid incident/disturbance not attributable to the transmission licensee, e.g. faults in a substation or bays owned by another agency causing an outage of the transmission licensee's elements, and tripping of lines, ICTs, HVDC, etc., due to grid disturbance. However, if the element is not restored on receipt of direction from RLDC while normalizing the system following grid incident/disturbance within reasonable time, the element will be considered not available for the period of outage after issuance of RLDC's direction for restoration;
  - iii) The outage period which can be excluded for the purpose of sub-clause (i) and (ii) of this clause shall be declared as under:
    - a. Maximum up to one month by the Member Secretary, RPC;
    - b. Beyond one month and up to three months after the decision at RPC;
    - c. Beyond three months by the Commission for which the transmission license shall approach the Commission along with reasons and steps taken to mitigate the outage and restoration timeline.
7. Time frame for certification of transmission system availability: (1) The following schedule shall be followed for certification of availability by the Member Secretary of the concerned RPC:

Transmission Service Agreement

- Submission of outage data along with documentary proof (if any) and TAFPn calculation by Transmission Licensees to RLDC/ constituents
  - By the 5<sup>th</sup> of the following month;
- Review of the outage data by RLDC / constituents and forward the same to respective RPC – by 20<sup>th</sup> of the month;
- Issue of availability certificate by respective RPC – by the 3<sup>rd</sup> of the next month.

## Appendix-V

## FORMULAE FOR CALCULATION OF AVAILABILITY OF EACH CATEGORY OF TRANSMISSION ELEMENTS

For AC transmission system

$$AV_o(\text{Availability of } o \text{ no. of AC lines}) = \frac{\sum_{i=1}^o W_i(T_i - TNA_i)/T_i}{\sum_{i=1}^o W_i}$$

$$AV_q(\text{Availability of } q \text{ no. of ICTs}) = \frac{\sum_{k=1}^q W_k(T_k - TNA_k)/T_k}{\sum_{k=1}^q W_k}$$

$$AV_r(\text{Availability of } r \text{ no. of SVCs}) = \frac{\sum_{l=1}^r W_l(T_l - TNA_l)/T_l}{\sum_{l=1}^r W_l}$$

$$AV_p(\text{Availability of } p \text{ no. of Switched Bus reactors}) = \frac{\sum_{m=1}^p W_m(T_m - TNA_m)/T_m}{\sum_{m=1}^p W_m}$$

$$AV_u(\text{Availability of } u \text{ no. of STATCOMs}) = \frac{\sum_{n=1}^u W_n(T_n - TNA_n)/T_n}{\sum_{n=1}^u W_n}$$

$$AV_{xpb}(\text{Availability of an individual HVDC pole}) = \frac{(T_x - TN)}{T_x}$$

$AV_{ybb}$  (Availability of an individual HVDC

$$\text{Back-to-back Blocks}) = \frac{(T_y - TNA_y)}{T_y}$$

## Transmission Service Agreement

**For the HVDC transmission system**

For the new HVDC commissioned but not completed twelve months;

For first 12 months:  $[(AV_{xbsp} \text{ or } AV_{ybtb}) \times 95\% / 85\%]$ , subject to a ceiling of 95%.

Where,

o	=	Total number of AC lines;
AVo	=	Availability of o number of AC lines;
p	=	Total number of bus reactors/switchable line reactors;
AVp	=	Availability of p number of bus reactors/switchable line reactors;
q	=	Total number of ICTs;
AVq	=	Availability of q number of ICTs;
r	=	Total number of SVCs;
AVr	=	Availability of r number of SVCs;
U	=	Total number of STATCOM;
AVu	=	Availability of u number of STATCOMs;
Wi	=	Weightage factor for <i>i</i> th transmission line;
Wk	=	Weightage factor for <i>k</i> th ICT;
Wl	=	Weightage factors for inductive & capacitive operation of <i>l</i> th SVC;
Wm	=	Weightage factor for <i>m</i> th bus reactor;
Wn	=	Weightage factor for <i>n</i> th STATCOM.
$T_i, T_k, T_l,$ ,		The total hours of <i>i</i> <sup>th</sup> AC line, <i>k</i> <sup>th</sup> ICT, <i>l</i> <sup>th</sup> SVC, <i>m</i> <sup>th</sup> Switched Bus Reactor
$T_m, T_n, T_x,$ $T_y$		& <i>n</i> <sup>th</sup> STATCOM, <i>x</i> <sup>th</sup> HVDC pole, <i>y</i> <sup>th</sup> HVDC back-to-back blocks during the period under consideration (excluding time period for outages not attributed to transmission licensee for the reasons given in Para 5 of the procedure)
$T_{NAi}, T_{NAk}$		The non-availability hours (excluding the time period for outages not $T_{NAi}, T_{NAm}$ , attributable to transmission licensee taken as deemed availability as $T_{NAi}, T_{NAk}, T_{NAx}, T_{NAy}$ per Para 5 of the procedure) for <i>i</i> <sup>th</sup> AC line, <i>k</i> <sup>th</sup> ICT, <i>l</i> <sup>th</sup> SVC, <i>m</i> <sup>th</sup> Switched Bus Reactor, <i>n</i> <sup>th</sup> STATCOM, <i>x</i> <sup>th</sup> HVDC pole and <i>y</i> <sup>th</sup> HVDC back-to-back block.

**Schedule: 7**

**Entire Bid (both financial bid and technical bid) of the Selected Bidder to be attached here**

**Schedule: 8**

**Contract Performance Guarantee**

**(To be on non-judicial stamp paper of appropriate value as per Stamp Act relevant to place of execution. Foreign entities submitting Bids are required to follow the applicable law in their country.)**

In consideration of the.....[Insert name of the SPV or Selected Bidder on behalf of the TSP, or Lead Member in case of the Consortium, with address] agreeing to undertake the obligations under the Transmission Service Agreement dated .....and the other RFP Project Documents and the Nodal Agency and the .....[Insert the name of the BPC], agreeing to execute the *RFP Project Documents* with the Selected Bidder, regarding setting up the Project, the.....[Insert name and address of the bank issuing the guarantee and address of the head office] (hereinafter referred to as "Guarantor Bank") hereby agrees unequivocally, irrevocably and unconditionally to pay to.....(being the Nodal Agency) \_at .....[Insert the Place from the address of the Nodal Agency indicated in the TSA] forthwith on demand in writing from the Nodal Agency or any Officer authorized by it in this behalf, any amount up to and not exceeding Rupees..... Crores (Rs. ....) only [Insert the amount of the bank guarantee] on behalf of M/s. .... [Insert name of the Selected Bidder or SPV].

This guarantee shall be valid and binding on the Guarantor Bank up to and including .....and shall not be terminable by notice or any change in the constitution of the Bank or the term of the Transmission Service Agreement or by any other reasons whatsoever and our liability hereunder shall not be impaired or discharged by any extension of time or variations or alternations made, given, or agreed with or without our knowledge or consent, by or between parties to the respective agreement.

Our liability under this Guarantee is restricted to Rs. .... Crores (Rs. ....) only. Our Guarantee shall remain in force until ..... [Insert the date of validity of the Guarantee as per Article 3.1.2 of this Agreement]. The Nodal Agency, shall be entitled to invoke this Guarantee up to three hundred sixty five (365) days of the last date of the validity of this Guarantee.

The Guarantor Bank hereby expressly agrees that it shall not require any proof in addition to the written demand from ..... (in its roles as the Nodal Agency), made in any format, raised at the above mentioned address of the Guarantor Bank, in order to make the said payment to Nodal Agency.

The Guarantor Bank shall make payment hereunder on first demand without restriction or conditions and notwithstanding any objection by ..... [Insert name of the Selected Bidder], ..... [Insert name of the TSP] and / or any other person. The Guarantor Bank shall not require Nodal Agency to justify the invocation of this BANK GUARANTEE, nor shall the Guarantor Bank have any recourse against Nodal Agency in respect of any payment made hereunder.

**THIS BANK GUARANTEE** shall be interpreted in accordance with the laws of India.

The Guarantor Bank represents that this BANK GUARANTEE has been established in such form and with such content that it is fully enforceable in accordance with its terms as against the Guarantor Bank in the manner provided herein.

**THIS BANK GUARANTEE** shall not be affected in any manner by reason of merger, amalgamation, restructuring, liquidation, winding up, dissolution or any other change in the constitution of the Guarantor Bank.

**THIS BANK GUARANTEE** shall be a primary obligation of the Guarantor Bank and accordingly Nodal Agency shall not be obliged before enforcing this BANK GUARANTEE to take any action in any court or arbitral proceedings against .....[Insert name of the SPV] or the Selected Bidder, as the case may be, to make any claim against or any demand on .....[Insert name of the SPV] or the Selected Bidder, as the case may be, or to give any notice to ..... [Insert name of the SPV] or the Selected Bidder, as the case may be, or to enforce any security held by the Nodal Agency or to exercise, levy or enforce any distress, diligence or other process against .....[Insert name of the SPV] or the Selected Bidder, as the case may be.

The Guarantor Bank acknowledges that this BANK GUARANTEE is not personal to Nodal Agency and may be assigned, in whole or in part, (whether absolutely or by way of security) by Nodal Agency to any entity to whom the Nodal Agency is entitled to assign its rights and obligations under the Transmission Service Agreement.

Transmission Service Agreement

The Guarantor Bank hereby agrees and acknowledges that Nodal Agency shall have a right to invoke this Bank Guarantee either in part or in full, as it may deem fit.

Notwithstanding anything contained hereinabove, our liability under this Guarantee is restricted to Rs. .... Crores (Rs. ....) only and it shall remain in force until .....[Date to be inserted on the basis of Article 3.1.2 of the Transmission Service Agreement], with an additional claim period of three hundred sixty five (365) days thereafter. This BANK GUARANTEE shall be extended from time to time for such period, as may be desired by ..... [Insert name of the Selected Bidder or Lead Member in case of the Consortium or SPV]. We are liable to pay the guaranteed amount or any part thereof under this Bank Guarantee only if Nodal Agency serves upon us a written claim or demand.

**In witness where of:**

Signature .....

Name: .....

Power of attorney No.: .....

**For:**

..... [Insert Name of the Bank]

**Banker's Seal and Full Address, including mailing address of the Head Office**

**SCHEDULE: 8A**

**(ISB for CPG)**

**FORMAT FOR SURETY INSURANCE CONTRACT**

**(To be on non-judicial stamp paper of appropriate value as per Stamp Act relevant to place of execution.**

**Foreign entities submitting Bids are required to follow the applicable law of India)**

In consideration of the ..... [Insert name of the SPV or Selected Bidder on behalf of SPV or Lead Member in case of the Consortium, with address] (hereinafter referred to as the '**Principal Debtor**' for the purposes of this Surety Insurance Contract as provided in Section 126 of the Indian Contract Act, 1872) having been selected to undertake the Transmission Project on the terms and conditions contained in the Transmission Service Agreement dated ...../ to be executed as per the Model Transmission Service Agreement provided along with the Request for Proposal ('**RFP**') and other RFP Project Documents, subject to the condition of providing a Performance Bank Guarantee or a Surety Insurance Contract guaranteeing/insuring the due performance of the obligations under the Transmission Service Agreement, to the Central Transmission Utility of India Limited ('**CTUIL**') [herein after referred to as the Nodal Agency], the [Insert name and address of the Insurance Company issuing the Surety Insurance Contract and address of the head office] (hereinafter referred to as "**Surety**") hereby agrees unequivocally, irrevocably, absolutely and unconditionally, without demur, to pay to the Nodal Agency at \_\_\_\_\_ [Insert Place and Address of the Nodal Agency indicated in Transmission Service Agreement, or to the designated Bank Account of the Nodal Agency, namely ] forthwith on demand in writing from the Nodal Agency, or any Officer authorized by it in this behalf, intimated to the Surety at the address mentioned above, any amount as may be decided by the Nodal Agency not exceeding Rupees..... Crores (Rs..... ) only [Insert the amount of the Surety Insurance Contract]

The Surety hereby acknowledges, accepts and confirms that the Surety has received from the Principal Debtor, by way of premium the entire consideration for the Surety to execute, in favour of the Nodal Agency, this Surety Insurance Contract, as extended by the Surety from time to time and assuming the obligation to pay to the Nodal Agency the amount in terms hereof, without any requirement for payment of any other consideration to the Surety by the Principal Debtor, or otherwise.

This Surety Insurance Contract shall be valid and binding on the Surety, as the principal obligation of the Surety to pay on demand by the Nodal Agency, and shall not be terminable by notice or any change in the constitution of the Surety or the term of the Transmission Service Agreement or by any other reasons whatsoever and the liability hereunder of the Surety shall not be impaired or discharged by any

extension of time or variations or alternations made, given, or agreed (with or without the knowledge or consent of the Surety) by or between the Principal Debtor and the Nodal Agency.

The liability of the Surety under this Surety Insurance Contract is restricted to Rupees ..... Crores (Rs ) only. The Surety Insurance Contract shall remain in force until [Insert the date of validity of the Surety Insurance Contract]. The Nodal Agency shall be entitled to invoke this Surety Insurance Contract up to three hundred sixty five (365) days after the last date of the validity of this Surety Insurance Contract.

The Surety hereby expressly agrees that it shall not require any proof except for the written demand from the Nodal Agency, containing the statement that the contractor has failed to meet its contractual obligations raised at the above mentioned address of the Surety (address of Surety office should be a place in NCR only) and the Surety shall pay the amount without reference to the Principal Debtor.

Any such demand made by the Nodal Agency on the Surety shall be conclusive and binding notwithstanding any difference between the Nodal Agency and the Principal Debtor or any dispute pending before any Court, Tribunal, Arbitrator or any other authority. The Surety undertakes not to revoke this guarantee during its currency without previous consent of the Nodal Agency and further agrees that the Surety Insurance Contract herein contained shall continue to be enforceable till the Nodal Agency discharges this contract or till the expiry of tenor (including Claim period) whichever is earlier.

The Surety shall make payment hereunder within two (02) working days on first demand without restriction or conditions and notwithstanding any objection by the Principal Debtor, namely, ..... [Insert name of SPV], or ..... [Insert name of the Selected Bidder], or ..... [Insert name of the TSP] and/or any other person. The Surety shall not require the Nodal Agency to justify the invocation of this Surety Insurance Contract, nor shall the Surety have any recourse against the Nodal Agency in respect of any payment made hereunder.

This **SURETY INSURANCE CONTRACT** shall be interpreted in accordance with the laws of India.

**This SURETY INSURANCE CONTRACT** is being executed by the Surety in terms of the IRDAI (Surety Insurance Contract) Guidelines, 2022 and the Surety hereby acknowledges, accepts and confirms that this Surety Insurance Contract shall be a Contract of Guarantee as provided under Section 126 of the Indian Contract Act, 1872 and further shall be covered by Section 14(3)(b) of the Insolvency and Bankruptcy Code, 2016 (as amended) shall be enforceable as such.

The Surety represents that this Surety Insurance Contract has been established in such form and with such content that it is fully enforceable in accordance with its terms as against the Surety in the manner provided herein.

**This SURETY INSURANCE CONTRACT** shall not be affected in any manner by reason of merger, amalgamation, restructuring, liquidation, winding up, dissolution or any other change in the constitution of the Surety.

In order to give effect to this surety Bond, the Nodal Agency shall be entitled to act as if the surety insurer were the principal debtor and any change in the constitution of the contractor and/or the surety insurer, whether by their absorption with any other body or corporation or otherwise, shall not in any way or manner affect the liability or obligation of the surety insurer under this surety Bond.

**This SURETY INSURANCE CONTRACT** shall be a primary obligation of the Surety as a Principal to pay on demand by the Nodal Agency and the Nodal Agency shall not be obliged before enforcing this Surety Insurance Contract to take any action in any court or arbitral proceedings against the Principal Debtor, namely, .....[Insert name of SPV], or ... ..[Insert name of the Selected Bidder], or ..... ..[Insert name of the TSP] and/or any other person, as the case may be, to make any claim against or any demand on the Principal Debtor, namely, ..... [Insert name of SPV], or ..... [Insert name of the Selected Bidder], or.....[Insert name of the TSP] and/or any other person, as the case may be, or to give any notice to Principal Debtor, namely..... [Insert name of SPV], or.....[Insert name of the Selected Bidder], or ..... [Insert name of the TSP] and/or any other person, as the case may be, or to enforce any security held by the Nodal Agency or to exercise, levy or enforce any distress, diligence or other process against the Principal Debtor, namely, ..... [Insert name of SPV], or ..... [Insert name of the Selected Bidder], or ..... [Insert name of the TSP] and/or any other person, as the case may be.

The Surety acknowledges that this Surety Insurance Contract is not personal to the Nodal Agency and may be assigned, in whole or in part, (whether absolutely or by way of security) by Nodal Agency to any entity to whom the Nodal Agency is entitled to assign its rights and obligations under the Transmission Service Agreement Provided that any such assignment shall be in compliance with the relevant provisions of the Insurance Act 1938

The Surety hereby agrees and acknowledges that the Nodal Agency shall have a right to invoke this Surety Insurance Contract either in part or in full, as it may deem fit. In case of invocation of this Surety Insurance Contract in part, besides making payment for the part of Surety Insurance Contract invoked, surety at the request of nodal agency shall amend the value of Surety Insurance Contract to the extent of balance amount.

Transmission Service Agreement

The Surety undertakes not to revoke this Surety Contract during its currency, except with the previous express consent of the Nodal Agency in writing and declares and warrants that it has the power to issue this Surety Contract and the undersigned has full powers to do so on behalf of the Surety

**In witness where of:**

Signature.....

Name: .....

Power of attorney No/ Employee No. as applicable.: .....

**For:**

.....[Insert Name of the Surety-Insurance Company]

Banker's Seal and Full Address, including mailing address of the Head Office

**Notes:**

1. The Stamp Paper should be in the name of the Executing Insurance Company

**SCHEDULE: 8B**

**(POI for CPG)**

**Format for Issuance of Payment on Order Instrument**

Dear Sir,

1. Indian Renewable Energy Development Agency Limited ("IREDA")/PFC/REC has sanctioned a non-fund based limit loan of Rs. (Rupees..... Only) to M/s. .... [Insert name of SPV or selected Bidder] under the Loan Agreement executed on..... to execute Transmission System Projects.

2. In consideration of the.....[Insert name of the SPV or Selected Bidder on behalf of SPV or Lead Member in case of the Consortium, with address] for the purposes of this Payment on Order Instrument ("POI") having been selected to undertake the Transmission Project on the terms and conditions contained in the Transmission Service Agreement dated ...../ to be executed as per the draft of the Model Transmission Service Agreement provided along with the Request for Proposal („RFP") and other RFP Project Documents, subject to the condition of providing a POI guaranteeing the due performance of the obligations under the Transmission Service Agreement to the Nodal Agency/Central Transmission Utility of India Limited („CTUIL"), the..... [Insert name and address of the non-banking financial institutions(IREDA/PFC/REC) issuing the POI and address of the head office] (hereinafter referred to as "Guarantor") hereby agrees unequivocally, irrevocably, absolutely and unconditionally, without demur, to pay to the Nodal Agency at ..... [Insert Place and Address of the Nodal Agency indicated in Transmission Service Agreement, or to the designated Bank Account of the Nodal Agency, namely .....] forthwith on demand in writing from the Nodal Agency, or any Officer authorized by it in this behalf, intimated to the Guarantor at the address mentioned above, any amount as may be decided by the Nodal Agency not exceeding Rupees ..... Crores (Rs ) only [Insert the amount of Payment on Order Instrument]

3. At the request of .....and on behalf of M/s. ...., [Insert name of SPV or selected Bidder] this Payment on Order Instrument (POI) for an amount of Rs.....(Rupees .....) is being issued with IREDA/PFC/REC assuming the obligations to remit such amount to CTUIL from the sanctioned loan.

4. This Payment on Order Instrument comes into force immediately and IREDA/PFC/REC confirms that it has sufficient amount out of the sanctioned loan and shall maintain the required amount to pay under this Payment on Order Instrument, during the validity and claim period of this Payment on Order Instrument.

5. This POI has been issued by IREDA/PFC/REC utilizing the credit limit of M/s.....[Insert name of SPV or selected Bidder]  
[Insert Name of the SPV]

IREDA/PFC/REC confirms that its liability to pay under this Payment on Order Instrument shall be primary and independent of whether at the time of invocation of Payment on Order Instrument, the sanctioned funds are available or not and notwithstanding, the status of M/s [Insert name of SPV or selected Bidder] at the relevant time and to whether IREDA/PFC/REC is able to recover the amount advanced by it to the said developer.

6. IREDA/PFC/REC and M/s.....[Insert name of SPV or selected Bidder] hereby acknowledges, accepts and confirms that this Payment on Order Instrument shall be a Contract of Guarantee as provided under Section 126 of the Indian Contract Act, 1872 and further shall be covered by Section 14(3)(b) of the Insolvency and Bankruptcy Code, 2016 (as amended) shall be enforceable as such.

7. IREDA/PFC/REC liability under this POI is restricted to Rupees Crores (Rs.....) only. This POI shall remain in force until..... [Insert the date of validity of the POI]. The Nodal Agency shall be entitled to invoke this POI up to three hundred sixty-five (365) days after the last date of the validity of this POI. This POI shall be extended from time to time for such period, as may be desired by the TSP.

8. The Guarantor hereby expressly agrees that it shall not require any proof except for the written demand from the Nodal Agency, raised at the above- mentioned address of the Guarantor (address of Guarantor office should be in NCR only) and the Guarantor shall pay the amount to the Nodal Agency without reference to the TSP.

9. Any such demand made by the Nodal Agency on the Guarantor shall be conclusive and binding notwithstanding any difference between the Nodal Agency and the TSP or any dispute pending before any Court, Tribunal, Arbitrator or any other authority. The Guarantor undertakes not to revoke this guarantee during its currency without previous consent of the Nodal Agency and further agrees that the POI herein contained shall continue to be enforceable till the Nodal Agency discharges this contract or till the expiry of tenure or (including Claim period) whichever is earlier.

10. The Guarantor shall make payment hereunder within two (02) working days on first demand without restriction or conditions and notwithstanding any objection or disputes raised by the TSP, namely, ..... [Insert name of SPV], or [Insert name of the Selected Bidder], or ..... [Insert name of the TSP] and/or any other person. The Guarantor shall not require the Nodal Agency to justify the invocation of this POI, nor shall the Guarantor have any recourse against the Nodal Agency in respect of any payment made hereunder.

11. This POI shall be interpreted in accordance with the laws of India.

12. The Guarantor represents that this POI Contract has been established in such form and with such content that it is fully enforceable in accordance with its terms as against the Guarantor in the manner provided herein.

13. This POI shall not be affected in any manner by reason of merger, amalgamation, restructuring, liquidation, winding up, dissolution or any other change in the constitution of the Guarantor.

14. This POI Contract shall be a primary obligation of the Guarantor as a Principal to pay on demand by the Nodal Agency and the Nodal Agency shall not be obliged before enforcing this POI Contract to take any action in any court or arbitral proceedings against the TSP, namely, ... .. [Insert name of SPV], or..... [Insert name of the Selected Bidder], or ..... [Insert name of the TSP] and/or any other person, as the case may be to make any claim against or any demand on the TSP, namely, ..... [Insert name of SPV], or ..... [Insert name of the Selected Bidder], or ..... [Insert name of the TSP] and/or any other person, as the case may be, or to give any notice to TSP, namely..... [Insert name of SPV], or ..... [Insert name of the Selected Bidder], or..... [Insert name of the TSP] and/or any other person, as the case may be, or to enforce any security held by the Nodal Agency or to exercise, levy or enforce any distress, diligence or other process against the TSP, namely, ..... [Insert name of SPV], or ..... [Insert name of the Selected Bidder], or ..... [Insert name of the TSP] and/or any other person, as the case may be.

15. The Guarantor acknowledges that this POI Contract is not personal to the Nodal Agency and may be assigned, in whole or in part, (whether absolutely or by way of security) by Nodal Agency to any entity to whom the Nodal Agency is entitled to assign its rights and obligations under the Transmission Service Agreement.

16. The Guarantor hereby agrees and acknowledges that the Nodal Agency shall have a right to invoke this POI Contract either in part or in full, as it may deem fit. In case of invocation of this POI Contract in part, besides making payment for the part of POI Contract invoked, Guarantor at the request of Nodal Agency shall amend the value of POI Contract to the extent of balance amount.

IN WITNESS WHERE OF the non- banking financial institutions through its authorized officer, has set its hand and stamp on this..... day of.....at.....

Signature .....

Name:

Power of attorney No.:

..... For:

Transmission Service Agreement

..... [Insert Name of the non- banking financial institutions  
Company]

Seal and Full Address, including mailing address of the Head Office

**Schedule: 9**

**Methodology for determining the Relief Under Force Majeure Event & Change in Law during Construction Period**

The relief in the form of revision in tariff due to Force Majeure Event leading to extension of Scheduled COD for a period beyond one hundred eighty (180) days and/or Change in Law during the construction period shall be as under:

$$\Delta T = [(P \times d)] \div [1 - (1 + d)^{-n}]$$

Where,

$\Delta T$  = Change in Transmission Charges for each year

P = Sum of cumulative increase or decrease in the cost of the Project due to Change in Law and interest cost during construction corresponding to the period exceeding one hundred eighty (180) due to Force Majeure Event leading to extension of Scheduled COD for a period beyond one hundred eighty (180) days

n = number of years over which the Transmission Charges has to be paid

d = Discount rate as notified by the CERC, applicable on the Bid Deadline

The increase in Transmission Charges as stated above shall be applicable only if the value of increase in Transmission Charges as calculated above exceeds 0.30% (zero point three percent) of the quoted Transmission Charges of the TSP.

---

**SHARE PURCHASE AGREEMENT**

**BETWEEN**

**REC POWER DEVELOPMENT AND CONSULTANCY LIMITED**

**AND**

**[Insert Name of the SPV]**

**AND**

**[Insert Name of the Selected Bidder]**

---

**Dated : [insert date]**

---

## SHARE PURCHASE AGREEMENT

This **SHARE PURCHASE AGREEMENT** ('Agreement') made this \_\_\_\_\_ day of \_\_\_\_\_ [Insert Date of the Agreement] 2026 at New Delhi by and between:

**REC POWER DEVELOPMENT AND CONSULTANCY LIMITED**, a company incorporated under the Companies Act, 1956, having its registered office at Core 4, SCOPE Complex, 7, Lodhi Road, New Delhi 110 003, India (hereinafter referred to as "**REC PDCL**", which expression shall, unless it be repugnant to the context or meaning thereof, be deemed to mean and include its successors and permitted assigns) of the **FIRST PART**;

**AND**

.....[Insert Name of the SPV], a company incorporated under the Companies Act, 2013, having its registered office at Core 4, SCOPE Complex, 7, Lodhi Road, New Delhi 110 003, India (hereinafter referred to as "**Company**" which expression shall, unless repugnant to the context, mean and include its successors in interest) of the **SECOND PART**; and

**AND**

\_\_\_\_\_ [Insert Name of the Selected Bidder] a company incorporated under the Companies Act, 1956 having its registered office at \_\_\_\_\_ [Insert the registered office address of the Selected Bidder] (hereinafter referred to as "**Selected Bidder**" which expression shall, unless repugnant to the context or meaning thereof, be deemed to mean and include its successors and permitted assigns) of the **THIRD PART**.

**Note: [In case the Selected Bidder is a Bidding Consortium, the above immediate paragraph shall be replaced by the following:**

..... [Insert Name of the Lead Member], a company incorporated under the Companies Act, 1956 and having its registered office at ..... [Insert the registered office address of Lead Member]

**AND**

..... [Insert Name of the Member], a company incorporated under the Companies Act, 1956 and having its registered office at ..... [Insert the registered office address of Member] (hereinafter individually referred to as "**Partner 1**" and "**Partner 2**" respectively and collectively referred to as "**Selected Bidder**" which expression shall, unless repugnant to the context or meaning thereof, be deemed to mean and include its successors and permitted assigns) of the **THIRD PART**

**WHEREAS:**

- A. The Ministry of Power, Government of India, vide its notification no. 687 [F. No. 34- 15/3/2026-Trans] dated 12.02.2026 has appointed REC Power Development and Consultancy Limited to be the Bid Process Coordinator (BPC) for the purpose of selection of Bidder as Transmission Service Provider (TSP) to establish transmission system for “**Augmentation at Bhadla-III, Ramgarh PS and Kanpur (PG)**” through tariff based competitive bidding process.
- B. In accordance with the Bidding Guidelines, the BPC had initiated a competitive bidding process through issue of RFP for selecting a Successful Bidder to build, own, operate and transfer the Project comprising of the Elements mentioned in **Schedule 2** of the TSA. BPC had initiated this process in accordance with and on the terms and conditions mentioned in the RFP Project Documents (as defined hereinafter).
- C. BPC has incorporated the Company and has undertaken the preliminary studies, obtained certain approvals, etc. regarding the Project on behalf of the Company
- D. REC PDCL along with the Nominees hold one hundred per cent (100%) of the total issued and paid up equity share capital of the Company.
- E. Pursuant to the said Bid Process, \_\_\_\_\_ **[Insert Name of the Selected Bidder]** has been identified as the Selected Bidder vide Letter of Intent dated \_\_\_\_\_ **[Insert Date of the Letter of Intent]** issued by the BPC in favour of the Selected Bidder.
- F. As envisaged in the RFP, the Shares Seller (as defined hereinafter) has agreed to sell the Sale Shares (as defined hereinafter) to the Selected Bidder and the Selected Bidder has agreed to purchase the Sale Shares from the Shares Seller, subject to and on the terms and conditions set forth in this Agreement.

**NOW THEREFORE, IN CONSIDERATION OF THE MUTUAL COVENANTS AND AGREEMENTS SET FORTH IN THIS AGREEMENT AND FOR OTHER GOOD AND VALUABLE CONSIDERATION, THE PARTIES HEREBY AGREE AS FOLLOWS:**

**1. DEFINITIONS**

- 1.1 Capitalised terms in this Agreement, unless defined in this Agreement shall, in so far as the context admits, have the same meaning in this Agreement as has been ascribed to them in the TSA.
- 1.2 Additionally, the following terms shall have the meaning hereinafter respectively assigned to them herein below:

- (i) **“Acquisition Price”** shall mean INR \_\_\_\_\_ (Rupees \_\_\_\_\_ only) [*Insert the value of the Acquisition Price, both in figures and in words respectively*], which is the aggregate consideration payable by the Selected Bidder towards purchase of the Sale Shares at par and for taking over of all assets and liabilities of the Company as on the Closing Date subject to adjustment as per the audited accounts of the Company as on the Closing Date;
- (ii) **“Agreement”** or **“the Agreement”** or **“this Agreement”** shall mean this Share Purchase Agreement and shall include the recitals and/or annexures attached hereto, and the contracts, certificates, disclosures and other documents to be executed and delivered pursuant hereto, if any, and any amendments made to this Agreement by the Parties in writing;
- (iii) **“Bid Process”** shall mean the competitive bidding process initiated by the BPC, by issuance of RFP for selecting a Successful Bidder to build, own, operate and transfer the Project in accordance with and on the terms and conditions mentioned in the RFP Project Documents;
- (iv) **“Board”** shall mean the board of directors of the Company;
- (v) **“Closing Date”** shall mean a mutually agreed date between the Parties falling within the period as mentioned in clause 2.15.2 of RFP or on failure of such mutual agreement between the Parties shall be the date falling on the last date of such period;
- (vi) **“Encumbrance”** shall mean any mortgage, pledge, lien, charge, security assignment, hypothecation, trust, encumbrance or any other agreement having the effect of creating security interest;
- (vii) **“Letter of Intent”** shall have the meaning ascribed thereto under the Bid Documents;
- (viii) **“Nominees”** shall mean the Persons, who are named in **Annexure A** of this Agreement, holding the Sale Shares as nominees of REC PDCL;
- (ix) **“Party”** shall mean REC PDCL, Company and the Selected Bidder, referred to individually, and **“Parties”** shall mean REC PDCL, Company and the Selected Bidder collectively referred to, as relevant;
- (x) **“Person”** shall include an individual, an association, a corporation, a partnership, a joint venture, a trust, an unincorporated organisation, a joint stock company or other entity or organisation, including a government or political subdivision, or an agency or instrumentality thereof, and/or any other legal entity;

- (xi) **“RFP Project Documents”** shall mean the following documents, referred to collectively:
  - a) Transmission Service Agreement; and
  - b) this Agreement.
- (xii) **“Representations and Warranties”** shall mean the representations and warranties mentioned in **Clause 4** hereto;
- (xiii) **“RoC”** shall mean the Registrar of Companies;
- (xiv) **“Sale Shares”** shall mean \_\_\_\_\_[*Insert total number of shares of the Company*] shares, representing one hundred percent (100%) of the total issued, subscribed and fully paid-up equity share capital of the Company held by the Shares Seller and Nominees as more particularly described in **Annexure A** attached hereto;
- (xv) **“Shares”** shall mean the fully paid-up equity shares of Company, of face value Rs. 10 each;
- (xvi) **“Shares Seller”** shall mean REC PDCL; and
- (xvii) **“Transmission Services Agreement”** or **“TSA”** means the agreement titled ‘Transmission Services Agreement dated \_\_\_\_\_[*Insert Date of the TSA*] entered into between the Central Transmission Utility of India Limited (CTUIL) and **[Insert Name of the SPV]** pursuant to which the TSP shall build, own, operate and Transfer the Project and make available the assets of the Project on a commercial basis.

### 1.3 Interpretation Clause

Unless the context otherwise requires, the provisions of the TSA relating to the interpretation of the TSA shall apply to this Agreement as if they were set out in full in this Agreement and to this end are incorporated herein by reference.

## 2. TRANSFER OF SHARES

- 2.1 Subject to the terms and conditions of this Agreement, the Shares Seller agrees to sell and transfer to the Selected Bidder and the Selected Bidder hereby agrees to purchase from the Shares Seller, the Sale Shares free from Encumbrances together with all assets and liabilities of the Company with rights and benefits attached thereto in consideration of the Acquisition Price and the covenants, undertakings and the agreements of the Selected Bidder contained in this Agreement.
- 2.2 The Shares Seller hereby undertakes to cause the Nominees to transfer part of the Sale Shares held by them as nominees of the Shares Seller to the Selected Bidder and execute any documents required to deliver good title to the Sale Shares to the Selected Bidder.

## 3. CLOSING

- 3.1 Prior to the Closing Date, the Selected Bidder shall provide to the Shares Seller, valid share transfer forms duly stamped with requisite amount of stamp duty payable on the transfer of the Sale Shares (“**Share Transfer Forms**”).
- 3.2 On the Closing Date, the Shares Seller shall hand over to the Selected Bidder or its authorised representative, the original share certificates representing the Sale Shares (“**Sale Share Certificates**”) executed by the Shares Seller and the Nominees, simultaneously against the Selected Bidder handing over to the Shares Seller, demand drafts drawn in favour of the Shares Seller or by confirmation of RTGS transfer in favour of the Shares Seller, for the Acquisition Price payable to it.

Provided that prior to the handing over of the Sale Share Certificates to the Selected Bidder as mentioned above, the Selected Bidder shall provide satisfactory evidence to REC PDCL that on the Closing Date, the Selected Bidder has furnished the Contract Performance Guarantee to the Central Transmission Utility of India Limited (CTUIL) and is in a position to comply with all other requirements of Clause 2.15.2 of the RFP.

- 3.3 The Selected Bidder shall immediately upon receiving the Sale Share Certificates and the Share Transfer Forms, duly execute the Share Transfer Forms and duly lodge the Share Transfer Forms and the Share Certificates with the Company along with the names of its nominees to be appointed on the Board of the Company and the address within the jurisdiction of the RoC of New Delhi and Haryana, which would be the new registered office of the Company. The Company shall, upon receipt of the said documents from the Selected Bidder, do the following:
- (i) Immediately on the Closing Date convene a meeting of the Board, wherein the Board shall pass the following necessary resolutions:

- (a) approving the transfer of the Shares constituting the Sale Shares from the Shares Seller and the Nominees to the name of the \_\_\_\_\_ [Insert Name of the Selected Bidder] and transfer of all assets and liabilities of the Company as on Closing Date;
- (b) approving the \_\_\_\_\_ [Insert Name of the Selected Bidder] as a member of the Company and entering the name of the \_\_\_\_\_ [Insert Name of the Selected Bidder] and its nominees in the register of members.
- (c) changing the address of the registered office of the Company to the new address as provided by the Selected Bidder as per clause 3.3 above.
- (d) appointing the nominees of the Selected Bidder on the Board and accepting the resignations of the other existing Directors on the Board and the Chair of the meeting which was taken by one of the existing Directors shall be vacated and appointment of a new Chairman who shall be one of the newly appointed Director, for the rest of the meeting.

Immediately pursuant to the acceptance of resignation of the existing Directors and appointment of new Chairman, the newly constituted Board of Directors shall continue with the meeting and pass the following resolution:

- (e) terminating all the authorizations granted regarding the business and/or operations of the Company or the operations of the bank accounts of the Company, with prospective effect; and
  - (f) acknowledging and accepting the terms and conditions as contained in the executed copies of the RFP Project Documents and to abide by the provisions contained therein.
- (ii) Enter the name of the \_\_\_\_\_ [Insert Name of the Selected Bidder] and its nominees as the legal and beneficial owner of the Sale Shares, free of all Encumbrances, in the register of members of the Company;
  - (iii) Make the necessary endorsements on the Sale Share Certificates, indicating the name of the \_\_\_\_\_ [Insert Name of the Selected Bidder] and its nominees as the legal and beneficial owner of the Sale Shares evidenced there under;

- (iv) Return the original Sale Share Certificates, duly endorsed in the name of the \_\_\_\_\_ [Insert Name of the Selected Bidder] and its nominees, to the \_\_\_\_\_ [Insert Name of the Selected Bidder] and its nominees, as the case may be or its authorised representative;
  - (v) Handover all the statutory registers and records, if any, of the Company to the Selected Bidder.
  - (vi) Handover certified true copies of the Board resolution passed by the Company as per (i) (a) to (i) (f) of Clause 3.3 (i) to the Central Transmission Utility of India Limited (CTUIL)
- 3.4 The Parties to this Agreement agree to take all measures that may be required to ensure that all the events contemplated in the **Clauses 3.1 to 3.3** above on the Closing Date are completed on the same day.

Notwithstanding the provisions of **Clause 3.3** hereto, all proceedings to be taken and all documents to be executed and delivered by the Parties at the Closing Date shall be deemed to have been taken and executed simultaneously and no proceedings shall be deemed to have been taken nor documents executed or delivered until all have been taken, executed and delivered.

- 3.5** The Selected Bidder hereby acknowledges and agrees that after the date of acquisition of one hundred percent (100%) of the Shares of the Company by the Selected Bidder as per Clause 3.3, (a) the authority of the BPC in respect of the Bid Process shall forthwith cease and any actions to be taken thereafter regarding the Bid Process will be undertaken by the Central Transmission Utility of India Limited (CTUIL), (b) all rights and obligations of the BPC shall cease forthwith, (c) all other rights and obligations of the Company shall be of the TSP and (d) any decisions taken by the BPC on behalf of the Company prior to the date of acquisition, shall continue to be binding on the Company and/or Central Transmission Utility of India Limited (CTUIL) as the case may be.
- 3.6 This Agreement shall be effective from the date of its signing by the Parties and shall remain in force until all the obligations of the respective Parties under Clause 3.3 hereto are fulfilled.

#### **4. REPRESENTATIONS AND WARRANTIES**

- 4.1 The Selected Bidder hereby represents and warrants to the Shares Seller that:
- 4.1.1 The Selected Bidder has full legal right, power and authority to enter into, execute and deliver this Agreement and to perform the obligations, undertakings and transactions set forth herein, and this Agreement has been duly and validly executed and delivered by the Selected Bidder and constitutes its legal, valid and binding obligations, enforceable against it in accordance with its terms;

- 4.1.2 The execution, delivery and performance of this Agreement by the Selected Bidder will not violate or contravene any provision of the Memorandum of Association or Articles of the Selected Bidder, (ii) will not violate or contravene any law, statute, rule, regulation, licensing requirement, order, writ, injunction or decree of any court, governmental instrumentality or other regulatory, governmental or public body, agency or authority by which the Selected Bidder is bound or by which any of its and/or their properties or assets are bound, and (iii) except to the extent that the same have been duly and properly completed or obtained, will not require any filing with, or permit, consent or approval of or license from, or the giving of any notice to, any court, governmental instrumentality or other regulatory, governmental or public body, agency or authority, joint venture party, or any other entity or person whatsoever; and
- 4.1.3 The Selected Bidder is not restricted in any manner whatsoever, including without limitation, on account of any judicial or governmental order, action or proceeding, or any contractual obligation assumed by the Selected Bidder, from purchasing the Sale Shares from the Shares Seller in the manner provided for in this Agreement.
- 4.2 The Shares Seller hereby represents and warrants to the Selected Bidder that;
- 4.2.1 The Shares Seller and the Nominees are the legal and beneficial owners of the Sale Shares, free and clear of any Encumbrance and the delivery to the Selected Bidder of the Sale Shares pursuant to the provisions of this Agreement will transfer to the Selected Bidder a good title to the Sale Shares.
- 4.2.2 The Shares Seller has full legal right, power and authority to enter into, execute and deliver this Agreement and to perform the obligations, undertakings and transactions set forth herein. The execution, delivery and performance of this Agreement will not violate the Memorandum and Articles of Association of the Shares Seller or contravene any contract by which it is bound.
- 4.2.3 The Shares Seller has obtained requisite authorizations to sell and transfer the Sale Shares to the Selected Bidder. The Shares Seller also represent that it is not prevented from transferring and selling the Sale Shares. Also, to the best of its knowledge, the Sale Shares are not the subject matter of any claim or pending proceeding or threatened by any legal proceeding made by any third party.

- 4.3 Except as specified in Clause 4.2 above, the Shares Seller shall not be deemed to have, made any representation or warranty whatsoever, whether express or implied, in relation to the Sale Shares or Company, including but not limited to any implied warranty or representation as to the business or affairs of Company.
- 4.4 The Representations and Warranties are given as at the date of this Agreement except that where a Representation and Warranty is expressed to be made as at another date, the Representation and Warranty is given with respect to that date only.
- 4.5 Each Representation and Warranty is to be construed independently of the others and is not limited by reference to any other Warranty. The Representations, Warranties and undertakings contained in this **Clause 4** hereto or in any document delivered pursuant to or in connection with this Agreement are continuing in nature and shall survive the Closing Date for a period of one (1) year.
- 4.6 The Parties represent to each other that all Representations and Warranties provided herein by the respective Party shall be true as of Closing Date.

**5. OBLIGATIONS OF THE SELECTED BIDDER**

The Selected Bidder agrees that the Shares Seller shall not be liable in any manner, nor shall it assume any responsibility or liability whatsoever, in respect of the business of the Company and its operations or activities, arising after the Closing Date, to any Person or any authority, central, state, local or municipal or otherwise and the same shall be the sole responsibility of the Selected Bidder.

**6. MISCELLANEOUS**

**6.1 NOTICES**

- a) All notices to be given under this Agreement shall be in writing and in the English language.
- b) All notices must be delivered personally or by registered or certified mail or by recognised courier to the addresses below:

Selected Bidder: \_\_\_\_\_ *[Insert details of the address for correspondence (Lead Member in case of Consortium)]*

REC PDCL: **REC Power Development and Consultancy Limited**

Core-4, SCOPE Complex, 7, Lodhi Road,  
New Delhi-110003

Company: ..... **[Insert Name of the SPV]**  
Core-4, SCOPE Complex, 7, Lodhi Road,  
New Delhi-110003

- c) Any Party may by notice of at least fifteen (15) days to the other Parties change the address and / or addresses to which such notices and communications to it are to be delivered or mailed.

## **6.2 RESOLUTION OF DISPUTES**

- 6.2.1 If any dispute arises between the Parties, in connection with the validity, interpretation, implementation or alleged breach of any provision of this Agreement (“Dispute”), the disputing Parties hereto shall endeavour to settle such Dispute amicably. The attempt to bring about an amicable settlement shall be considered to have failed if not resolved within sixty (60) days from the date of the Dispute.
- 6.2.2 If the Parties are unable to amicably settle the Dispute in accordance with Clause 6.2.1 within the period specified therein, any of the Parties shall be entitled to within thirty (30) days after expiry of the aforesaid period, refer the Dispute to the Company Secretary of REC PDCL and Chief Executive/ Managing Director of the Selected Bidder for resolution of the said Dispute. The attempt to bring about such resolution shall be considered to have failed if not resolved within thirty (30) days from the date of receipt of a written notification in this regard.
- 6.2.3 In the event the Dispute is not settled in accordance with Clause 6.2.2 above, any Party to the Dispute shall be entitled to serve a notice invoking this Clause and making a reference to a sole arbitrator. If the Parties to the Dispute cannot agree as to the appointment of the sole arbitrator within thirty (30) days of receipt of the notice of the Party making the reference, then the Shares Seller along with the Company shall appoint one arbitrator and the Selected Bidder shall appoint one arbitrator and the two arbitrators, so appointed shall appoint a third arbitrator. However, after the Closing Date, in such an event the Shares Seller shall appoint one arbitrator and the Selected Bidder along with the Company shall appoint one arbitrator and the two arbitrators, so appointed shall appoint the third arbitrator.
- 6.2.4 The place of the arbitration shall be New Delhi. The Arbitration proceedings shall be governed by the Arbitration and Conciliation Act, 1996.

6.2.5 The proceedings of arbitration shall be in English language.

6.2.6 The arbitrator's award shall be substantiated in writing. The arbitrators shall also decide on the costs of the arbitration proceedings. In case the arbitrators have not decided on the costs of the arbitration proceedings, each Party to the Dispute shall bear its own costs, in relation to the arbitration proceedings.

### **6.3 AUTHORISED PERSON**

For the purposes of this Agreement, the Selected Bidder is represented by \_\_\_\_\_ [Insert Name of the authorized representative of the Selected Bidder/ Lead Member, in case of Consortium], pursuant to an authorization granted to \_\_\_\_\_ [Insert Name of the authorized representative of the Selected Bidder/Lead Member, in case of Consortium] through necessary Board resolutions. Further, \_\_\_\_\_ [Insert Name of the authorized representative of the Selected Bidder/Lead Member, in case of Consortium] is also authorized by such resolutions to take any decision which may be required to be taken, do all acts and execute all documents which are or may be required by the Selected Bidder for the proper and effective fulfillment of the rights and obligations under this Agreement. Any action taken or document executed by \_\_\_\_\_ [Insert Name of the authorized representative of the Selected Bidder/Lead Member, in case of Consortium] shall be deemed to be acts done or documents executed by the Selected Bidder and shall be binding on the Selected Bidder.

### **6.4 RESERVATION OF RIGHTS**

No forbearance, indulgence or relaxation or inaction by any Party at any time to require performance of any of the provisions of this Agreement shall in any way affect, diminish or prejudice the right of such Party to require performance of that provision, and any waiver or acquiescence by any Party of any breach of any of the provisions of this Agreement shall not be construed as a waiver or acquiescence of any continuing or succeeding breach of such provisions, a waiver of any right under or arising out of this Agreement or acquiescence to or recognition of rights other than that expressly stipulated in this Agreement.

### **6.5 CUMULATIVE RIGHTS**

All remedies of either Party under this Agreement whether provided herein or conferred by statute, civil law, common law, custom or trade usage, are cumulative and not alternative and may be enforced successively or concurrently.

## **6.6 PARTIAL INVALIDITY**

If any provision of this Agreement or the application thereof to any person or circumstance shall be invalid or unenforceable to any extent, the remainder of this Agreement and the application of such provision to persons or circumstances other than those as to which it is held invalid or unenforceable shall not be affected thereby, and each provision of this Agreement shall be valid and enforceable to the fullest extent permitted by law. Any invalid or unenforceable provision of this Agreement shall be replaced with a provision, which is valid and enforceable and most nearly reflects the original intent of the unenforceable provision.

## **6.7 TERMINATION**

If (i) the Closing does not occur on the Closing Date for any reason whatsoever, or (ii) the Letter of Intent is withdrawn or terminated for any reason, or (iii) due to termination of the TSA by the Central Transmission Utility of India Limited (CTUIL) in accordance with Article 3.3.2 or Article 13 of the TSA thereof, REC PDCL shall have a right to terminate this Agreement forthwith by giving a written notice to the other Parties hereto.

## **6.8 AMENDMENTS**

No modification or amendment of this Agreement and no waiver of any of the terms or conditions hereof shall be valid or binding unless made in writing and duly executed by all the Parties.

## **6.9 ASSIGNMENT**

This Agreement and the rights and liabilities hereunder shall bind and inure to the benefit of the respective successors of the Parties hereto, but no Party hereto shall assign or transfer its rights and liabilities hereunder to any other Person without the prior written consent of the other Parties, which will not be unreasonably withheld.

## **6.10 ENTIRE AGREEMENT**

This Agreement constitutes the entire Agreement between the Parties with respect to the subject matter herein and supersedes and cancels any prior oral or written agreement, representation, understanding, arrangement, communication or expression of intent relating to the subject matter of this Agreement.

## **6.11 COSTS**

Each of the Parties hereto shall pay their own costs and expenses relating to the negotiation, preparation and execution of this Agreement and the transactions contemplated by this Agreement.

The Selected Bidder shall be liable to bear and pay the costs in respect of this Agreement and transfer of Sale Shares.

#### **6.12 RELATIONSHIP**

None of the provisions of this Agreement shall be deemed to constitute a partnership between the Parties hereto and no Party shall have any authority to bind the other Party otherwise than under this Agreement or shall be deemed to be the agent of the other in any way.

#### **6.13 GOVERNING LAW AND JURISDICTION**

This Agreement shall be governed by and construed in accordance with the laws of India and shall be subject to the exclusive jurisdiction of the courts of Delhi.

#### **6.14 COUNTERPARTS**

This Agreement may be executed in counterparts by the Parties and each fully executed counterpart shall be deemed to be original.

#### **6.15 CONFIDENTIALITY**

The Parties undertake to hold in confidence and not to disclose the terms and conditions of the transaction contemplated hereby to third parties, except:

- (a) to their professional advisors;
- (b) to their officers, employees, agents or representatives, who need to have access to such information for the proper performance of their activities;
- (c) disclosures required under Law;

without the prior written consent of the other Parties.

Provided that the Central Transmission Utility of India Limited (CTUIL) and REC PDCL may at any time, disclose the terms and conditions of transactions contemplated hereby to any person, to the extent stipulated under the law or the Bidding Guidelines.

#### **6.16 INDEMNIFICATION**

The Parties hereby agree that transfer of Sale Shares to the Selected Bidder shall vest all the rights, privileges, licenses, responsibilities, liabilities and other obligations pertaining to the Company in the Selected Bidder.

- The Selected Bidder hereby agrees that the Selected Bidder shall not be entitled to any claims or initiate any legal proceedings by itself or through the Transmission Service Provider against the Share Sellers, its directors, officers, employees and the subscribers including the members of any committees appointed by them in respect of any actions or decisions taken by any of them up to the Closing Date in furtherance of the Project referred to in recital A of this Agreement.
- Further, the Selected Bidder hereby indemnifies and holds harmless at all times the Share Seller against all past, present and future third party claims and liabilities arising out of actions or decisions taken by any of the persons or bodies referred to in Clause 6.3 up to the Closing Date in furtherance of the Project referred to above or otherwise concerning the Company. All such actions shall be defended by the Selected Bidder either itself or through the TSP at its own cost.
- The Parties hereby agree that the provisions of this clause shall survive the termination of this Agreement.

#### **6.17 SURVIVAL**

The provisions of Clause 1 (Definitions and Interpretation), Clause 4 (Representations and Warranties), Clause 6.2 (Dispute Resolution), Clause 6.7 (Termination), Clause 6.15 (Confidentiality), Clause 6.16 (Indemnification) and other representations, warranties, covenants and provisions contained herein that by their nature are intended to survive, shall survive the termination of this Agreement

#### **6.18 FORCE MAJEURE**

No party shall be liable for its inability or delay in performing any of its obligations hereunder if such delay is caused by circumstances beyond the reasonable control of the party including delay caused through flood, riot, Act of God, lighting civil commotion, storm, tempest and earthquake.

**IN WITNESS WHEREOF, THE PARTIES HERETO HAVE CAUSED THIS AGREEMENT TO BE DULY EXECUTED AND DELIVERED AS OF THE DAY AND YEAR FIRST ABOVE WRITTEN**

SIGNED AND DELIVERED by The within named **REC Power Development and Consultancy Limited** by the hand of Sh. \_\_\_\_\_ authorised pursuant to the resolution passed by its board of directors in its meeting held on \_\_\_\_\_

IN THE PRESENCE OF:

WITNESS: 1. \_\_\_\_\_ 2. \_\_\_\_\_  
(name and address)

SIGNED AND DELIVERED by The within named .....[**Insert Name of the SPV**] by the hand of Sh. \_\_\_\_\_, its Chairman, authorised pursuant to the resolution passed by its board of directors in its meeting held on \_\_\_\_\_

IN THE PRESENCE OF

WITNESS: 1. \_\_\_\_\_ 2. \_\_\_\_\_  
(name and address)

SIGNED AND DELIVERED by The within named [insert name of the selected bidder] by the hand of Sh. \_\_\_\_\_, its \_\_\_\_\_, authorised pursuant to the resolution passed by its board of directors in its meeting held on \_\_\_\_\_

IN THE PRESENCE OF:

WITNESS:  
(Name and Address)

**ANNEXURE A****DESCRIPTION OF THE SALE SHARES**

<b>S. NO.</b>	<b>NAME OF THE SHAREHOLDER</b>	<b>NUMBER OF EQUITY SHARES HELD</b>	<b>PERCENTAGE OF THE TOTAL PAID UP EQUITY CAPITAL</b>
1.	<b>REC Power Development and Consultancy Limited</b> through its _____	49,994	99.988
2.		1	0.002
3.		1	0.002
4.		1	0.002
5.		1	0.002
6.		1	0.002
7.		1	0.002
	<b>Total</b>	50,000	100.000

\*Held as nominee of RECPDCL